

# Series

# GP8155AGBHS

# GP8160AGBHS

# GP8165AGBHS

Triplex Ceramic  
Plunger Pump  
Operating Instructions  
Repair and Service Manual

---

Hydraulic Drive Pumps with Gearbox

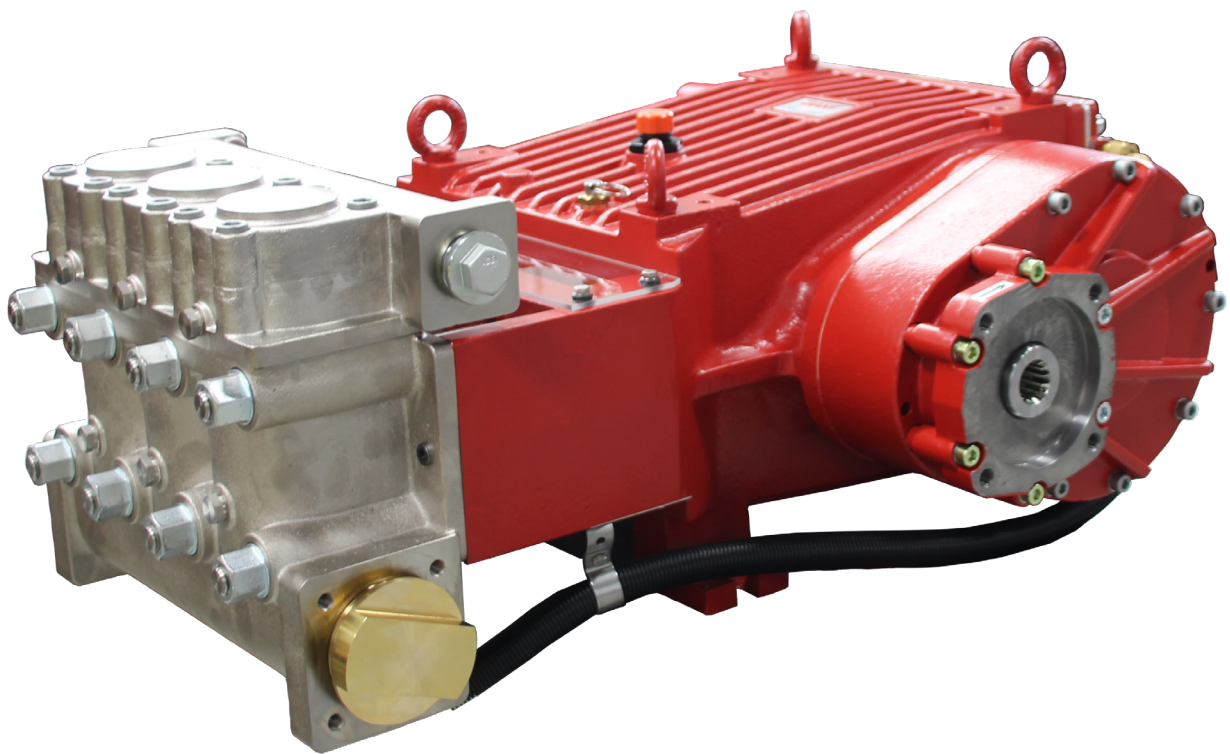

---

**GIANT**  
Performance Under Pressure

<b>Contents:</b>	
Installation Instructions:	page 2
Operating Instructions:	page 3
Pump Specifications:	page 4
Exploded View:	page 6
Parts List:	page 7
Repair Kits:	page 9
Tool List/Torque Specifications/ Troubleshooting Chart:	page 10
Repair Instructions:	pages 11-14
Dimensions:	page 15
Warranty Information:	back page

# INSTALLATION INSTRUCTIONS

The stated figures are for maximum pressure and maximum speed (rpm) and apply for interval operation with cold water.

Required NPSH refers to water (specific weight 1kg/dm<sup>3</sup>, viscosity 1°E) at maximum permissible pump revolutions.

Fluid medium: Clean water filtered with 200µm.

**Note:** Higher temperatures are possible with separate crankcase cooling system; if needed, contact Giant Industries.

## Operation and Maintenance

Check oil level prior to starting and ensure trouble-free water supply.

**IMPORTANT!** If there is a **danger of frost**, the water in the pump and in the pump fittings (particularly the unloader valve) must be emptied. The second discharge port can also be used and the pump run “dry” for 1-2 minutes for this purpose.

Oil amount: 4.2 gallons (16.0 litres). Only use **ISO VG 220 industrial gear oil** (e.g. Aral Degol BG220) or **automobile gear oil SAE 90 GL4 (Giant’s p/n 01154)**. Initial change after 50 operating hours and then every 1000 operating hours after one year latest.

**IMPORTANT!** When operating in damp places or with high temperature fluctuations. Oil must be changed immediately should condensate (frothy oil) occur in the gear end.

**NPSH values must be observed.**

## Cooling the Gear Oil

**IMPORTANT!** When using the integrated system for cooling the gear oil, the water input pressure must not exceed 29 PSI (2 bar). If a **separate** cooling circuit maximum 29 PSI (2 bar) is installed, it is then possible to have an input pressure of up to maximum 145 PSI (10 bar) on the **suction side** of the pump.

Make sure that suction pulsation is sufficiently dampened – water column resonance must be avoided.

**IMPORTANT!** The pumps can be run without gear oil cooling in continuous operation **up to** a power rating of **94 HP (70 kW)** or with major intermittent operation at full performance.

If operational power **exceeds 94 HP (70 kW)** or if continuous operation is the case, the pump must be run with the integrated oil cooling system. The maximum temperature of the water being pumped and which is also fed through the cooling system must not exceed 86 °F (30°C). The water amount which is fed into the cooling system depends on the pump speed and is approximately 1.8 GPM (7.0 L/min) at 580 pump rpm. The cooling water is sucked in by one of the pumping chambers and pumped away.

**Definition of intermittent operation:** operation at full performance for not more than altogether 20 minutes an hour, with the pump running without pressure or turned off in between. For example, this can be full load operation for 5 minutes four times an hour with 10 minute breaks in between or continuous full load operation for 20 minutes followed by a 40 minute break.

**IMPORTANT!** If higher medium temperatures or liquids other than water are involved or aggressive media such as seawater, demineralised water etc., the pump must be fitted with a separate cooling circuit. The separate cooler must have a cooling efficiency of 1700 watt. If there is a danger of frost, an appropriate amount of antifreeze must be mixed into the cooling circuit.

When starting up for work, the pump must run first at zero pressure for approximately 1 minute.

**IMPORTANT!** The GP8100 series has a black arrow on the reduction gear which shows the preferred direction of rotation. The pumps can be delivered either with the gear on the left side or right side which eases the planning of assembling units with regard to rotational direction.

Gear on right side from behind pump = optimal rotation: to the left

Gear on left side from behind pump = optimal rotation: to the right

The preferred/optimal direction of rotation ensures the motion of the conrods correctly shovels the oil on to the crosshead guides – which is a particular advantage where continuous operation is involved.

# OPERATING INSTRUCTIONS

The pump can also be run against the recommended direction of rotation if operated periodically or at reduced pressure. If so, the pump has to be run in this direction to smoothen the bearing areas. This is done by a one-time operation at zero pressure for at least 30 minutes; thereafter, the pressure must be slowly increased over the next hour to the desired maximum operating pressure; the pump is then run in. During this process, check the oil temperature.

**IMPORTANT!** The pump and cooling system must be emptied if there is a danger of frost. Travel wind can cause water in pumps fitted on open vehicles to freeze even if the outside temperature is above freezing point.

To empty the cooling circuit, remove the L-joints (K11) on the pump head (50). Blow out the circuit liquid at the joint connection (K11/K7) using compressed air.

The torque tension on the valve casing nuts (49A) is to be checked after approximately 200 operating hours. Please see page 5 concerning the torque values.

When checking the torque tension, the pump must be at zero pressure.

**IMPORTANT!** The service life of the seals is maximized if a minimal amount of leakage is present. A few drops of water can drip from each plunger every minute. Leakage has to be examined every day; the plunger seals must be changed should leakage become excessive (=constant dripping).

## Safety Rules

**The operating instructions must be read and adhered to before performing any work on the pump or complete assembled unit. No responsibility will be carried by us for damage to materials or persons caused by improper handling of our pumps.**

Access to the pump is not allowed for unauthorized personnel. A safety valve is to be installed in accordance with the guidelines for liquid spraying units so that the admissible operating pressure cannot be exceeded by more than 10%. Pump operation without a safety valve as well as any excess in temperature or speed limits automatically voids the warranty.

When the pump is in operation, the driven shaft side and its coupling must be covered by a protective guard. The plunger area must also be covered by the protective plate (30).

Do not step onto the protective plate (30) nor put weight on it.

Pressure in the discharge line and pump must be at zero before carrying out any maintenance work to the pump or unit. Close off suction line. Disconnect fuses to ensure that the driving motor cannot get switched on accidentally. Make sure that the pump, the cooling system and all parts on the pressure side of the unit are vented and refilled, with pressure at zero, before starting the pump.

In order to prevent air or an air/water-mixture being absorbed and cavi-tation occurring, the pump-npshr, positive suction head and water temperature must be respected.

**Cavitation and/or compression of gases lead to uncontrollable pressure-kicks which can ruin the pump and unit parts and also be dangerous to the operator or anyone standing nearby.**

Giant plunger pumps are suitable for pumping clean water and other non-aggressive or non-abrasive media with a specific weight similar to water.

**Before pumping other liquids - especially inflammable, explosive and toxic media - the pump manufacturer must be consulted with regard to the resistance of the pump material. It is the responsibility of the equipment manufacturer and/or operator to ensure that all pertinent safety regulations are adhered to.**

# GP8155AGBHS/GP8160AGBHS/GP8165AGBHS Specifications

## U.S. Measurements

	Max. Flow	Max. Pressure	Max. Speed	Power Required	Plunger Diameter	NPSHR
Model	GPM	PSI	RPM	HP	in	foot of head
GP8155	75.3	3000	580	145	2.17	23
GP8160	90	2500	580	147	2.36	23.6
GP8165	106/120*	2000	580/657*	142	2.56	26.2

## Metric Measurements

	Max. Flow	Max. Pressure	Max. Speed	Power Required	Plunger Diameter	NPSHR
Model	L/min	Bar	RPM	kW	mm	mWs
GP8155	285	200	580	108	55	7.0
GP8160	340	170	580	110	60	7.2
GP8165	400/455*	140	580/657*	106	65	8.0

\*Intermittent duty only

	U.S.	(Metric)
Maximum Inlet Pressure .....	Up to 29 PSI*	(2.0 bar)*
Plunger Stroke .....	2.83"	72mm
Maximum Temperature of Pumped Fluids .....	Up to 86 °F*	(30 °C)*
Hollow Shaft Dimensions .....		SAE-C Spline 14T 12/24 DP
Crankshaft Mounting .....		Either side
Shaft Rotation .....		See Page 2
Inlet Ports .....		(2) 3" BSP
Discharge Ports .....		(2) 1-1/4" BSP
Crankcase Oil Capacity .....	4.2 Gal.	(16.0 liters)
Weight .....	794 lbs.	(360kg)
Fluid End Material .....		Nickel plated Spheroidal Cast Iron

\*see note on page 2

Consult the factory for special requirements that must be met if the pump is to operate beyond one or more of the limits specified above.

GP8155 Horsepower Requirements					
RPM	GPM	500 PSI	1000 PI	2000 PSI	3000 PSI
300	39	13.9	27.9	55.7	83.6
400	52	18.6	37.1	74.3	111.4
500	65	23.2	46.4	92.9	139.3
580	75.5	27.0	53.9	107.9	161.8

GP8165 Horsepower Requirements					
RPM	GPM	500 PSI	750 PSI	1000 PSI	2000 PSI
300	54	18.6	27.9	37.2	74.5
400	72	24.8	37.2	49.7	99.3
500	91	31.4	47.1	62.8	125.5
580	105	36.2	54.3	72.4	144.8
657	120	41.4	62.1	82.8	165.5

GP8160 Horsepower Requirements					
RPM	GPM	500 PSI	1000 PSI	2000 PSI	2500 PSI
300	47	16.8	33.6	67.1	81.0
400	62	22.1	44.3	88.6	106.9
500	78	27.9	55.7	111.4	134.5
580	90	32.1	64.3	128.6	155.2

**HORSEPOWER RATINGS:**  
 To compute specific pump horsepower requirements, use the following formula:  

$$\frac{\text{GPM} \times \text{PSI}}{1450} = \text{HP}$$

**For the Application of a Hydraulic Motor:**  
 To Determine the Torque of a Hydraulic Motor--  

$$(\text{GPM} \times \text{PSI} \times 36.77) / \text{RPM} = \text{Torque (in-lbs)}$$

## Pump Repair Kits - GP8155AGBHS/GP8160AGBHS/GP8165AGBHS

### Plunger Packing Kit - GP8155AGBHS # 09616

<u>Item</u>	<u>Part #</u>	<u>Description</u>	<u>Qty.</u>
38A	13286	O-Ring	6
38B	05281	Support Ring	6
39A	05066	O-Ring	3
40	07723	Seal Ring	3
42	05277	Sleeve	9

### Plunger Packing Kit - GP8160AGBHS # 09617

<u>Item</u>	<u>Part #</u>	<u>Description</u>	<u>Qty.</u>
38A	06667	O-Ring	6
39A	05066	O-Ring	3
40	05067	Seal Ring	3
42	05069	Sleeve	9

### Plunger Packing Kit - GP8165AGBHS # 09586

<u>Item</u>	<u>Part #</u>	<u>Description</u>	<u>Qty.</u>
38A	06667	O-Ring	6
39A	05066	O-Ring	3
40	06996	Seal Ring	3
42	06997	V-Sleeve	9

### Inlet Valve Kit #09587

<u>Item</u>	<u>Part #</u>	<u>Description</u>	<u>Qty.</u>
51	04186	Inlet Valve Assembly	3
56A	06258	O-Ring	3

### Discharge Valve Kit #09588

<u>Item</u>	<u>Part #</u>	<u>Description</u>	<u>Qty.</u>
52	04188	Discharge Valve Assembly	3
56A	06258	O-Ring	3

### Oil Seal Kit #09584

<u>Item</u>	<u>Part #</u>	<u>Description</u>	<u>Qty.</u>
32	05058	Radial Shaft Seal	3
33A	05056	O-Ring	3

<b>Tool List and Torque Specifications</b>		
<b>Item</b>	<b>Torque ft-lbs (Nm)</b>	<b>Tool Needed</b>
24	37 (50)	8 mm Allen Wrench
33B	N/A	Industrial Snap Ring Pliers
36C	30 (40)	16 mm Socket
49A	265 (360)	30 mm Socket
51 & 52	N/A	Valve Puller (p/n 07662) included w/pump
58	132 (180)	12 mm Allen Wrench
K5	N/A	8 mm Allen Wrench

# Exploded View - GP8155AGBHS/GP8160AGBHS/GP8165AGBHS

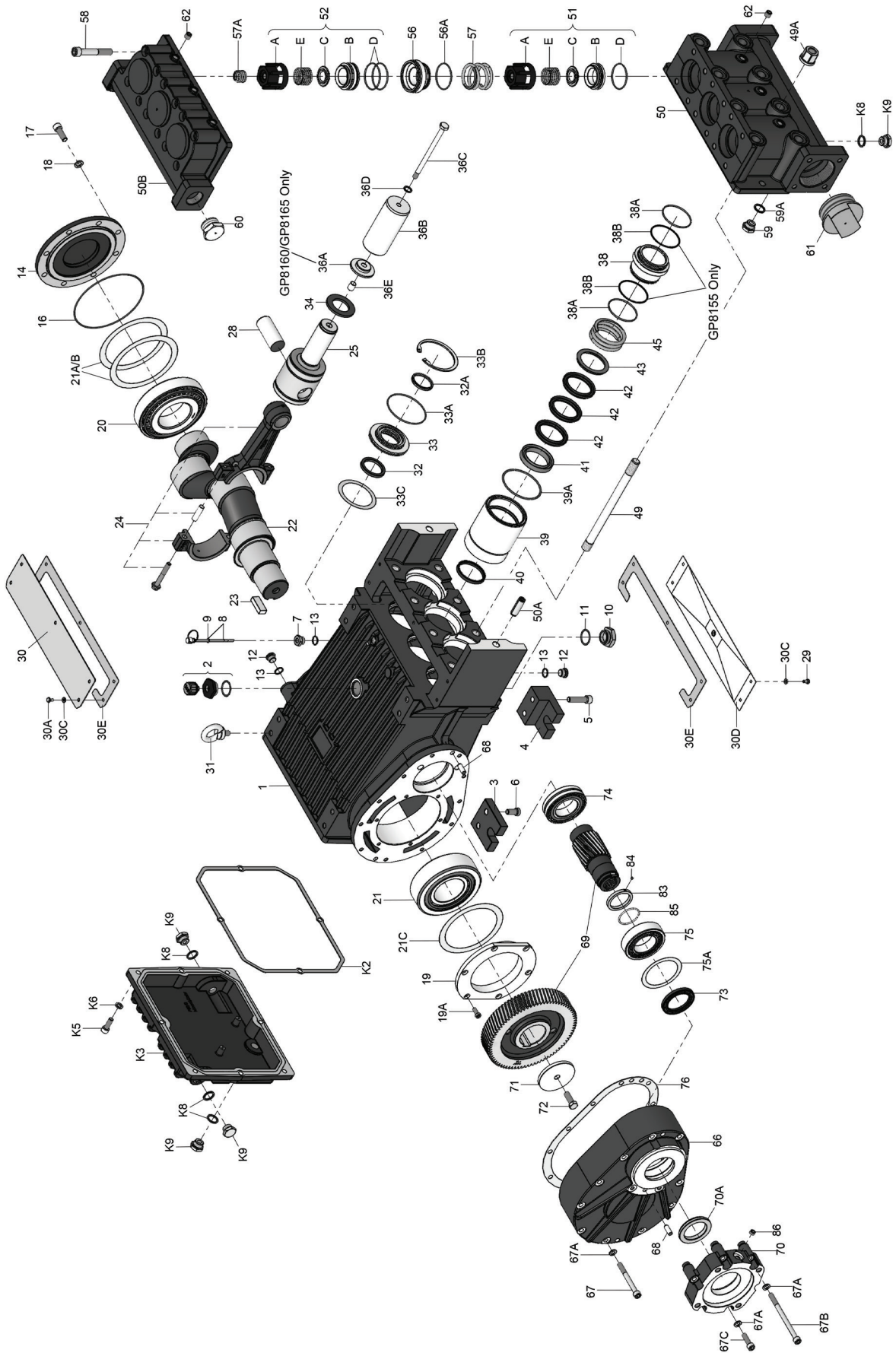

## Parts List - GP8155AGBHS/GP8160AGBHS/GP8165AGBHS

<u>Item</u>	<u>Part</u>	<u>Description</u>	<u>Qty</u>	<u>Item</u>	<u>Part</u>	<u>Description</u>	<u>Qty</u>
1	03300	Crankcase	1	41	05117	Pressure Ring, GP8165	3
2	06893	Oil Filler Plug Assembly with Vent	1	42	05277	Sleeve, GP8155	9
3	05652	Rear Foot for Crankcase	2	42	05069	Sleeve, GP8160	9
4	05653	Front Foot for Crankcase	2	42	06997	Sleeve, GP8165	9
5	05654	Hexagon Socket Screw	4	43	05278	Sleeve Support Ring, GP8155	3
6	05655	Hexagon Socket Screw	4	43	05070	Sleeve Support Ring, GP8160	3
7	05656	Plug, 3/8" for Oil Dipstick	1	43	05118	Sleeve Support Ring, GP8165	3
8	04185	Oil Dipstick Assembly	1	45	05279	Seal Tension Spring, GP8155	3
9	01009	O-Ring	1	45	05071	Seal Tension Spring, GP8160	3
10	05657	Plug, M33 X 1.5	1	45	05119	Seal Tension Spring, GP8165	3
11	07102	O-Ring	1	49	05072	Stud Bolt	8
12	12256	Plug 3/8" BSP	3	49A	05073	Hexagon Nut	8
13	22929	Copper Washer	4	50	05074-NPT	Valve Casing	1
14	05036	Bearing Cover Closed	1	50A	13162	Centering Stud	2
16	05037	O-Ring	1	50B	05075-NPT	Discharge Casing	1
17	05038	Hexagon Socket Screw, M12	8	51	04186	Suction Valve Assembly	3
18	05039	Spring Ring	8	51A	04166	Spring Tension Cap	3
19	05765	Flange	1	51B	05078	Suction Valve Seat	3
19A	05766	Hexagon Socket Screw	6	51C	05079	Valve Plate	3
20	05658	Tapered Roller Bearing	1	51D	07658	O-Ring	3
21	05659	Tapered Roller Bearing	1	51E	05080	Valve Spring	3
21A	05042	Fitting Disc	1-3	52	04188	Discharge Valve Assembly	3
21B	05043	Fitting Disc	1-3	52A	04166	Spring Tension Cap	3
21C	05113	Fitting Disc	1-3	52B	05084	Discharge Valve Seat	3
22	05741	Crankshaft For Gear	1	52C	05079	Valve Plate	3
23	05661	Fitting Key	1	52D	06258	O-Ring	6
24	05047	Connecting Rod Assembly	3	52E	05080	Valve Spring	3
25	05048	Crosshead c/w Plunger	3	56	05085	Discharge Valve Adaptor	3
28	05049	Crosshead Pin	3	56A	06258	O-Ring	3
29	05051	Hexagon Screw	4	57	05086	Pressure Spring	3
30	03802	Cover Plate	1	57A	07210-0100	Pressure Spring	3
30A	05051	Hexagon Screw	5	58	05087	Hexagon Socket Screw	12
30C	08280	Washer	9	59	07109	Plug, 1/2" BSP	3
30D	05050	Splash Cover	1	59A	06272	Copper Seal	3
30E	03803	Cover Seal	2	60	12251	Plug, 1-1/4" NPT	1
31	07623	Eye Bolt	4	61	03795	Plug, 3" BSP	1
32	05058	Radial Shaft Seal	3	62	22610	Plug, 1/4" BSP	6
32A	03118	Scraper	3	66	03193	Gear Cover	1
33	05055	Seal Retainer	3	67	08484	Hexagon Screw	7
33A	05056	O-Ring	3	67A	08041	Washer	13
33B	05054	Clip Ring	3	67B	03391	Hexagon Socket Screw	4
33C	05059	Fitting Disc	3	67C	03392	Hexagon Socket Screw	2
34	05060	Oil Shield	3	68	03304	Cylinder Pin	3
36A	05063	Plunger Pipe Cover, GP8160/GP8165	3	69	03393	Gear Wheel Set (2200 RPM=3.8)	1
36B	05280	Plunger, GP8155	3	70	03306	Flange for Gear	1
36B	05061	Plunger, GP8160	3	70A	03307	Centering Ring	1
36B	05115	Plunger, GP8165	3	71	04571	Spacer	1
36C	05062	Tension Screw	3	72	05667	Hexagon Screw	1
36D	07665	Copper Washer	3	73	05608	Shaft Seal Ring for Gear	1
36E	06900	Centering Sleeve	3	74	05668	Self-Aligning Roller Bearing	1
38	05283	Seal Case, GP8155	3	75	05669	Roller Bearing	1
38	05064	Seal Case, GP8160/GP8165	3	75A	05670	Fitting Disc	1
38A	13286	O-Ring, GP8155	6	76	03309	Gear Seal	1
38A	06667	O-Ring, GP8160/GP8165	6	79	07662	Valve Puller (Not Shown)	1
38B	05281	Support Ring, GP8155 Only	6	83	03394	Ring for Speed Sensor	1
39	05275	Seal Sleeve, GP8155	3	84	03295	Magnet for Speed Sensor	1
39	05065	Seal Sleeve, GP8160	3	85	03395	Round Wire Circlip	1
39	05116	Seal Sleeve, GP8165	3	86	03297	Plug, M 12 x 1	1
39A	05066	O-Ring	3	K2	03791	Seal for Gear Cover	1
40	07723	Seal Ring, GP8155	3	K3	03792	Gear Cover	1
40	05067	Seal Ring, GP8160	3	K5	22706	Hexagon Socket Screw	8
40	06996	Seal Ring, GP8165	3	K6	06725	Washer	8
41	05276	Pressure Ring, GP8155	3	K8	06272	Copper Seal	5
41	05068	Pressure Ring, GP8160	3	K9	07109	Plug, 1/2" BSP	5

# GP8155AGBHS/GP8160AGBHS/GP8165AGBHS

## Pump Repair Instructions

### To Check Valves

Loosen screws (58), lift discharge casing (50B) up and away. Take out pressure springs (57A). Pull out assembled valve assemblies (51 and 52) with tool (p/n 07662).

**Dismantling valves:** the spring tension cap (51A, 52A) is screwed together with the valve seat (51B and 52B respectively). Screw off spring tension cap, take out springs (51E, 52E) and valve plate (51C, 52C). Check sealing surfaces and O-rings (51D, 52D).

Replace worn parts.

Before re-fitting the valves, clean the sealing surfaces in the casings (50 and 50B) and check for any damage.

Tighten screws (58) at 132 ft.-lbs. (180 Nm); check torque tension after 8-10 operating hours.

### To Check Seals and Plunger Pipe

Screw off hexagon nuts (49A). Remove pump head together with seal case (38) from crankcase (1). If necessary, carefully tap the valve casing (50) past the centring stud (50A) using a rubber hammer.

**IMPORTANT!** If necessary, support the pump head by resting it on wooden blocks or by using a pulley.

Remove tension screw (36C) and take seal sleeve (39) together with all mounted parts out of the drive.

Pull plunger pipe (36B) out of seal assembly and check for any damage. Pry seal rings (40) and sleeves (42) out of the seal sleeve with a screw-driver.

**IMPORTANT!** Be careful not to damage seal sleeve (39) and pressure ring (41). Check the inner diameter of the pressure ring for wear and if necessary replace together with seals (40) and (42). Clean all parts. New parts should be lightly coated with silicon grease before installation.

Insert the seal unit (40, 41, 42, 43) in to the sleeve. Push the ceramic plunger carefully through the seals from the crankcase side. If necessary, the seals can be held tightly using a suitable pipe support held on the other side of the seal sleeve.

Take out the seal case (38) from the valve casing (50) and check O-rings (38A). If necessary, secure 2 screwdrivers in the front O-ring groove to extract seal casing from valve casing. Coat seals with silicon grease before installing.

**IMPORTANT!** Mounting surfaces of the crankcase and valve casing must be clean and free of damage. The components must lie exactly and evenly on one another. The same exactness applies for all centring positions in the crankcase, pressure and valve casing.

Coat the seal sleeve lightly with anti-corrosive grease (e.g. molycote no. Cu-7439) in its fitted area towards the crankcase. Coat the step of the plunger pipe cover (36A for GP8160 and GP8165 only) lightly with silicon grease and press on to the back end of the plunger pipe. Insert seal sleeves in to their crankcase fittings. Coat the threads of the tension screw (36C) lightly with thread glue and insert it together with a new copper ring (36D) through the ceramic pipe. Turn the pump per hand until the plunger (25) rests against the plunger pipe. Tighten tension screw at 30 ft.-lbs. (40 Nm).

**IMPORTANT!** Thread glue must never come between the plunger pipe (36B) and plunger cover (36A). Overtensioning of the plunger pipe by excessive tightening of the tension screw and/or dirt or damage on the mounting surfaces can lead to plunger pipe breakage.

Insert the seal tension spring (45) and O-ring (39A) in to the seal sleeve (39).

### Mounting Valve Casing:

Put seal cases (38) in the centring holes of the valve casing, then push valve casing carefully on to centring studs (50A).

Tighten hexagon screws (49A) evenly and crosswise at 265 ft.-lbs. (360 Nm).

**IMPORTANT!** The torque tension on the screws (49A) must be checked after 8-10 operating hours; the pump must be at zero pressure. Thereafter the tension is to be checked every 200 operating hours.

# GP8155AGBHS/GP8160AGBHS/GP8165AGBHS

## Pump Repair Instructions

### To Dismantle Crankcase Gear

Take out plungers and seal sleeves as described above.

Drain oil by taking off plug (12).

After removing the clip ring (33B), lever out the seal retainer (33) with a screwdriver.

Remove gear cover (K3). Remove connecting rod screws (24).

**IMPORTANT!** Connecting rods are marked for identification. Do not twist connecting rod halves or interchange them. When reassembling, the connecting rods must be fitted in their exact original position on the crankshaft journals.

Push connecting rod halves together with the crosshead as far as possible into the crosshead guide.

Screw off bearing cover (14), remove shims (21A/B/C).

### To Dismantle Reduction Gear

Remove screws (67). Press off gear cover (66) by screwing two screws into both thread bores. Remove screw (72) and take off spacer (71).

Remove the cogwheel from the shaft with a removal tool. Using a rubber hammer, tap out the crankshaft towards bearing cover (14).

Check surfaces on the connecting rods (24), crankshaft (22) and crossheads (25). Check the surfaces of the crosshead guides in the crankcase for any unevenness.

Reassemble in reverse order. Thread the crankshaft in from the bearing cover side until the bearing rests cleanly in the outer ring on flange (19).

Press in the outer ring from bearing (20) and using shims (21A/B/C), adjust the bearing to be free of play. To achieve this, add shims, screw on cover (14) and turn the crankshaft until it can no longer be turned by hand.

Then remove a shim and establish whether the crankshaft can now be turned. A crankshaft that can be too easily turned may cause damage later to the bearings and connecting rods due to wobble movements in the conical bearing shells.

Mount connecting rod halves in their exact original position and tighten at 37 ft.-lbs. (50 Nm).

Connecting rods must be able to move slightly sideways on the stroke journals.

### To Mount Reduction Gear

Mount gear cover (K3) with their respective seal (K2).

Heat ball bearings (75 and 74) first before pressing them on to the pinion. Press the cogwheel slightly on to the crankshaft so that the pinion (69) together with the bearing (74) can still be inserted.

Move the pinion (69) against the cogwheel and make them mate perfectly when mounting. Then carefully tap the cogwheel and the pinion simultaneously on to the crankshaft and into the bearing seat.

Fit spacer (71), and secure screw (72) with Loctite.

Fit the seal (76) on to the cylindrical pins (68).

Push the gear cover (66) carefully on to the bearing (75). Make sure that the radial shaft seal (73) does not get damaged during fitting on to the pinion.

**IMPORTANT!** Before putting in to operation again, turn the reduction gear shaft per hand at least four full turns to make sure the gear is correctly aligned.

**GP8155AGBHS/GP8160AGBHS/GP8165AGBHS**  
**Pump Dimensions - Inches (MM)**

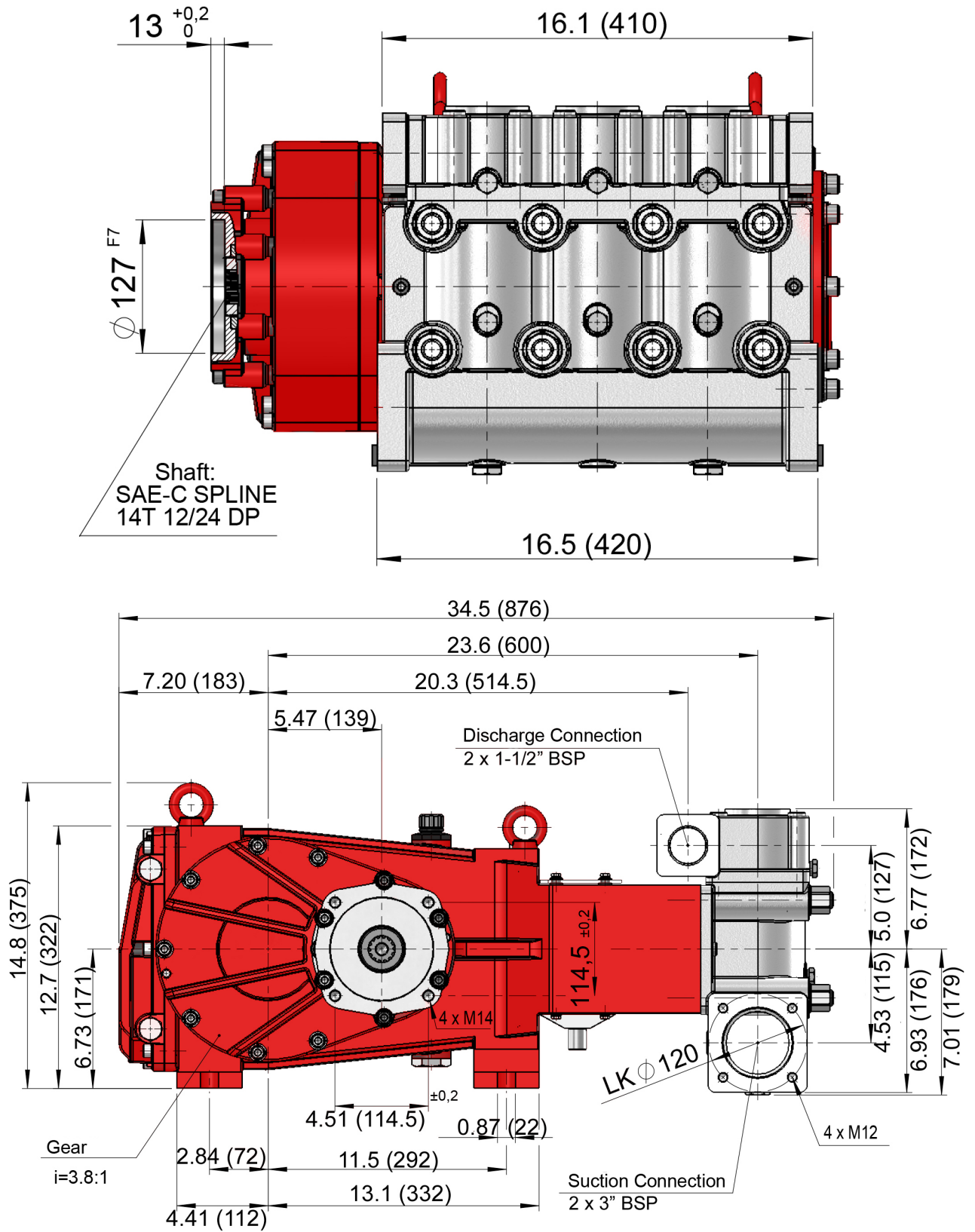

## GIANT INDUSTRIES LIMITED WARRANTY

Giant Industries, Inc. pumps and accessories are warranted by the manufacturer to be free from defects in workmanship and material as follows:

1. Five (5) years from the date of shipment for all pumps used in portable pressure washers with NON-SALINE, clean water applications.
2. Two (2) years from the date of shipment for Giant pumps used in car wash applications.
3. One (1) year from the date of shipment for all other Giant industrial and consumer pumps.
4. Six (6) months from the date of shipment for all rebuilt pumps
5. Ninety (90) days from the date of shipment for all Giant accessories.

This warranty is limited to repair or replacement of pumps and accessories of which the manufacturer's evaluation shows were defective at the time of shipment by the manufacturer. The following items are NOT covered or will void the warranty:

1. Defects caused by negligence or fault of the buyer or third party.
2. Normal wear and tear to standard wear parts.
3. Use of repair parts other than those manufactured or authorized by Giant.
4. Improper use of the product as a component part.
5. Changes or modifications made by the customer or third party.
6. The operation of pumps and or accessories exceeding the specifications set forth in the Operations Manuals provided by Giant Industries, Inc.

Liability under this warranty is on all non-wear parts and limited to the replacement or repair of those products returned freight prepaid to Giant Industries which are deemed to be defective due to workmanship or failure of material. A Returned Goods Authorization (R.G.A.) number and completed warranty evaluation form is required prior to the return to Giant Industries of all products under warranty consideration. Call (419)-531-4600 or fax (419)-531-6836 to obtain an R.G.A. number.

Repair or replacement of defective products as provided is the sole and exclusive remedy provided hereunder and the MANUFACTURER SHALL NOT BE LIABLE FOR FURTHER LOSS, DAMAGES, OR EXPENSES, INCLUDING INCIDENTAL AND CONSEQUENTIAL DAMAGES DIRECTLY OR INDIRECTLY ARISING FROM THE SALE OR USE OF THIS PRODUCT.

THE LIMITED WARRANTY SET FORTH HEREIN IS IN LIEU OF ALL OTHER WARRANTIES OR REPRESENTATION, EXPRESS OR IMPLIED, INCLUDING WITHOUT LIMITATION ANY WARRANTIES OR MERCHANTABILITY OR FITNESS FOR A PARTICULAR PURPOSE AND ALL SUCH WARRANTIES ARE HEREBY DISCLAIMED AND EXCLUDED BY THE MANUFACTURER.



**WARNING:** This product might contain a chemical known to the State of California to cause cancer, and birth defects or other reproductive harm.  
For more information go to [www.P65Warnings.ca.gov](http://www.P65Warnings.ca.gov)



**GIANT INDUSTRIES, INC.**, 900 N. Westwood Ave., Toledo, Ohio 43607  
PHONE (419) 531-4600, FAX (419) 531-6836, [www.giantpumps.com](http://www.giantpumps.com)  
© Copyright 2026 Giant Industries, Inc.