

Model GP8065-5100

Triplex Ceramic
Plunger Pump
Models Manual

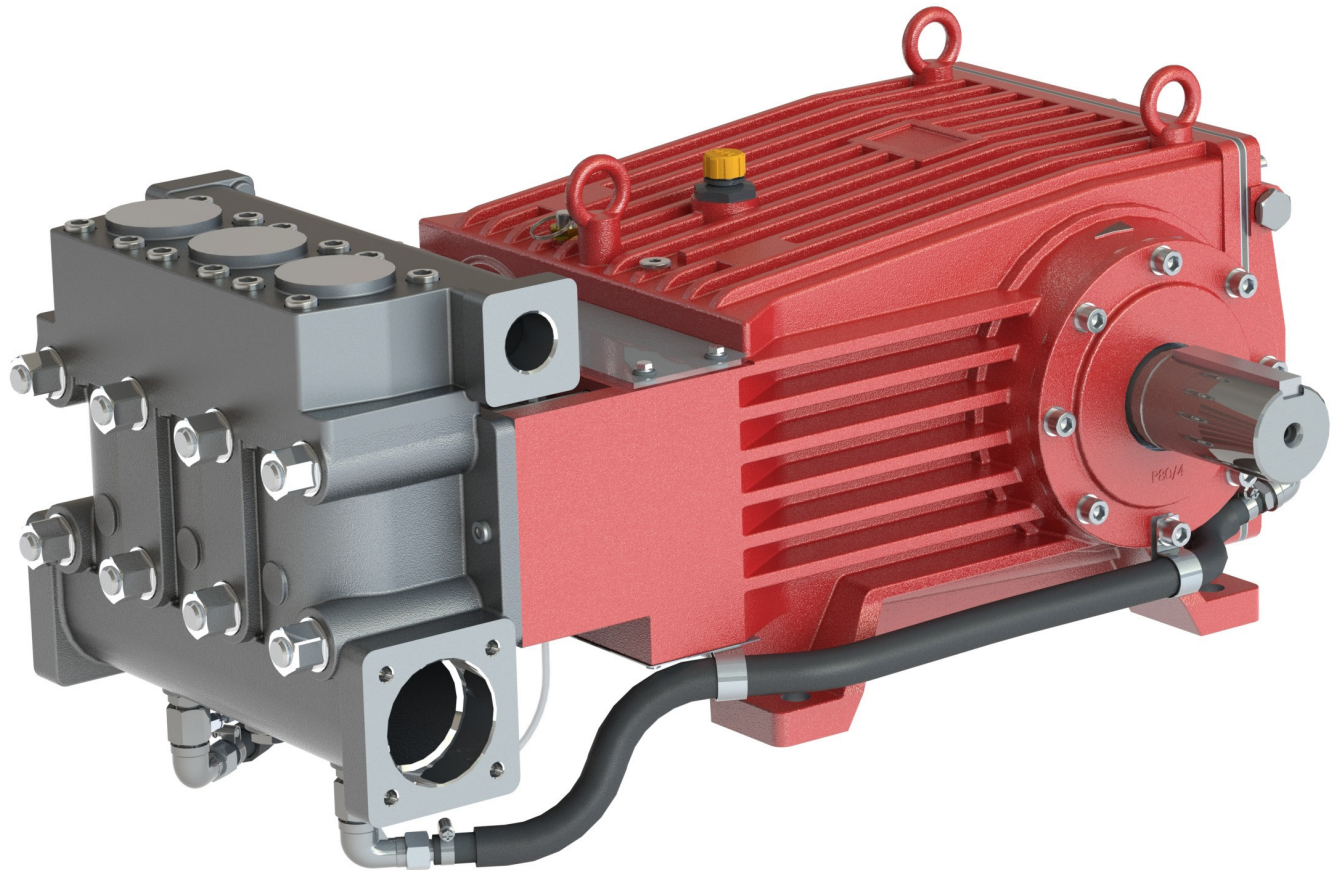

GIANT
Performance Under Pressure

Contents:

Installation Instructions:	page 2
Pump Specifications:	page 3
Exploded View:	page 4
Parts List/Repair Kits:	page 5
Repair Instructions:	page 6-7
Torque Specifications:	page 7
Dimensions:	back page
Warranty Information	back page

SPECIFICATIONS

Model	Max. Flow		Pressure		Max. Speed	Max. Inlet Pressure		Plunger Diameter		Power Req'd	
	GPM	l/min	PSI	bar	RPM	PSI	bar	in	mm	BHP	kW
GP8065-5100	106	400	2000	140	580	29	2	2.55	65	142	106

	U.S.	Metric
Plunger Stroke.....	2.83"	72mm
Crankshaft Diameter.....	2.76"	70mm
Key Width.....	0.55"	14mm
Crankshaft Mounting.....		Either side
Shaft Rotation.....		Top of pulley towards manifold
Temperature of Pumped Fluids (max)	86 °F	30 °C*
Inlet Ports.....		(2) 3" BSP
Discharge Ports.....		(2) 1-1/4" BSP
Weight.....	778 lbs.	353 Kg
Crankcase Oil Capacity.....	3.3 Gal.	12.5 Liters
Fluid End Material.....		AISI 316 Stainless Steel

*If higher temperature fluids are pumped, a separate cooling system may be required.

Contact Giant Industries for more information.

Consult the factory for special requirements that must be met if the pump is to operate beyond one or more of the limits specified above.

HORSEPOWER RATINGS:

The rating shown are the power requirements for the pump. Gas engine power outputs must be approximately twice the pump power requirements shown above.

We recommend a 1.15 service factor be specified when selecting an electric motor as the power source. To compute specific pump horsepower requirements, use the following formula:

$$HP = (GPM \times PSI) / 1450$$

GP8065-5100 HORSEPOWER REQUIREMENTS					
RPM	GPM	500 PSI	750 PSI	1000 PSI	2000 PSI
300	54.7	18.9	28.3	37.7	75.5
400	72.9	25.1	37.7	50.3	100.6
500	91.1	31.4	47.1	62.8	125.7
580	106.0	36.6	54.8	73.1	146.2

Figures given for maximum pressure and maximum speed (rpm) apply to intermittent operation with cold water.

Definition of intermittent operation:

Operation at full performance for not more than altogether 20 minutes an hour, with the pump running without pressure or turned off in between.

For example, this can be full load operation for 5 minutes four times an hour with 10 minute breaks in between or continuous full load operation for 20 minutes followed by a 40 minute break.

Higher water temperatures are possible with a separate external crankcase cooling system.

The manufacturer is to be contacted in this case. The maximum pressure is to be reduced by 10% where continuous operation with a cooler (with or without gear) is involved.

NPSHR / Inlet pressure

Required NPSH refers to water at 70 °F (20°C) at maximum permissible pump speed.

The inlet pressure on the suction side must not exceed 29 PSI (2 bar).

Make sure that suction pulsation is sufficiently dampened – water column resonance must be avoided.

Level of noise emission

Emission sound pressure level: ≤ 94 dB(A)

INSTALLATION INSTRUCTIONS

Fields of application

The fields of application of these pump types correspond to the specifications in the assembly instructions Giant Industries Pumps.

Ambient conditions

Ambient temperature: $41\text{ °F} < T_{\text{Amb.}} < 86\text{ °F}$

Ambient temperature: $5\text{ °C} < T_{\text{Amb.}} < 30\text{ °C}$

Oil filling

- Filling quantity: **3.3 gal (12,5 l)**
- Quality: Industrial gear oil **ISO VG 220** or automotive gear oil **SAE 90 GL4 (Giant's p/n 01154)**.
- Intervals: first oil change after **50 operating hours**, then every **1000 operating hours**, but at the latest after **12 months**.



If the pump is mounted on a vehicle (possible inclined position during operation) and/or if the pump speed is between 300 rpm and 500 rpm, the required oil quantity increases by 0.26 gallons (1 liter).

Installation/ Putting into Operation

Shaft protector

When the pump is in operation, the driven shaft side and coupling by a contact-protector and the plunger room by cover (30).

Do not step onto the protective plate (30) nor put heavy objects on it.

Direction of pump rotation

An arrow on the pump crankcase indicates the recommended direction of rotation for the drive shaft.

The indicated direction ensures that oil is correctly distributed on and into the crosshead guides via optimal connecting rod motion thus providing best possible lubrication particularly with regard to continuous operation.

The pump can also be run against the recommended direction of rotation if operated periodically or at reduced pressure.

If so, the pump must be run in in this direction to smoothen the bearing areas.

This is done by initially operating the pump at zero pressure for 30 minutes; thereafter the pressure is to be slowly increased over a period of an hour to the desired max. operating pressure.

Check the oil temperature during this process.

Suction line filter

Recommended mesh size 50 µm.

Gear oil cooling



The pumps can be run without gear oil cooling in continuous operation up to a power rating of 107 HP (80 kW) or with major intermittent operation at full performance.

If operational power exceeds 107 HP (80 kW) in continuous operation, the pump must be run with the integrated oil cooling system. The maximum temperature of the water being pumped and which is also fed through the cooling system must not exceed 86 °F (30 °C).

The water amount which is fed into the cooling system depends on the pump speed and is approximately 1.8 GPM (7.0 l/min) at nominal speed. The cooling water is sucked in by one of the pumping chambers and pumped away.



If higher medium temperatures or liquids other than water are involved or aggressive media such as seawater, demineralised water etc., the pump must be fitted with a separate cooling circuit.

The separate cooler must have a cooling efficiency of 1700 watt.

If there is a danger of frost, an appropriate amount of antifreeze must be mixed into the cooling circuit.

Valve Casing

The torque tension on the valve casing nuts (49A) is to be checked after approx. 200 operating hours. Please see page 7 concerning the torque values.

The pump must be at zero pressure when checking the torque tension.

Operation

When starting up for work, the pump must run first at zero pressure for approximately 1 minute.

The pump and cooling system must be emptied if there is a danger of frost. Note that travel wind, for example, can cause water in pumps fitted on open vehicles to freeze even if the outside temperature is above freezing point.

Empty the pump through the second unused suction and discharge connection using compressed air, for example. Bottom plugs (12) on the suction channel can be opened as well.

The pump can also be run "dry" for 1-2 minutes to aid emptying.

Empty the cooling system by removing screw joints (K11) on the pump head (50) and by blowing the hoses (K12) with compressed air on the (K11/K7) side.

The service life of the seals is maximized if a minimal amount of leakage is present.

A few drops of water can drip from each plunger every minute.

Leakage has to be examined every day; the plunger seals must be changed should leakage become excessive (=constant dripping).

Exploded View - GP8065-5100

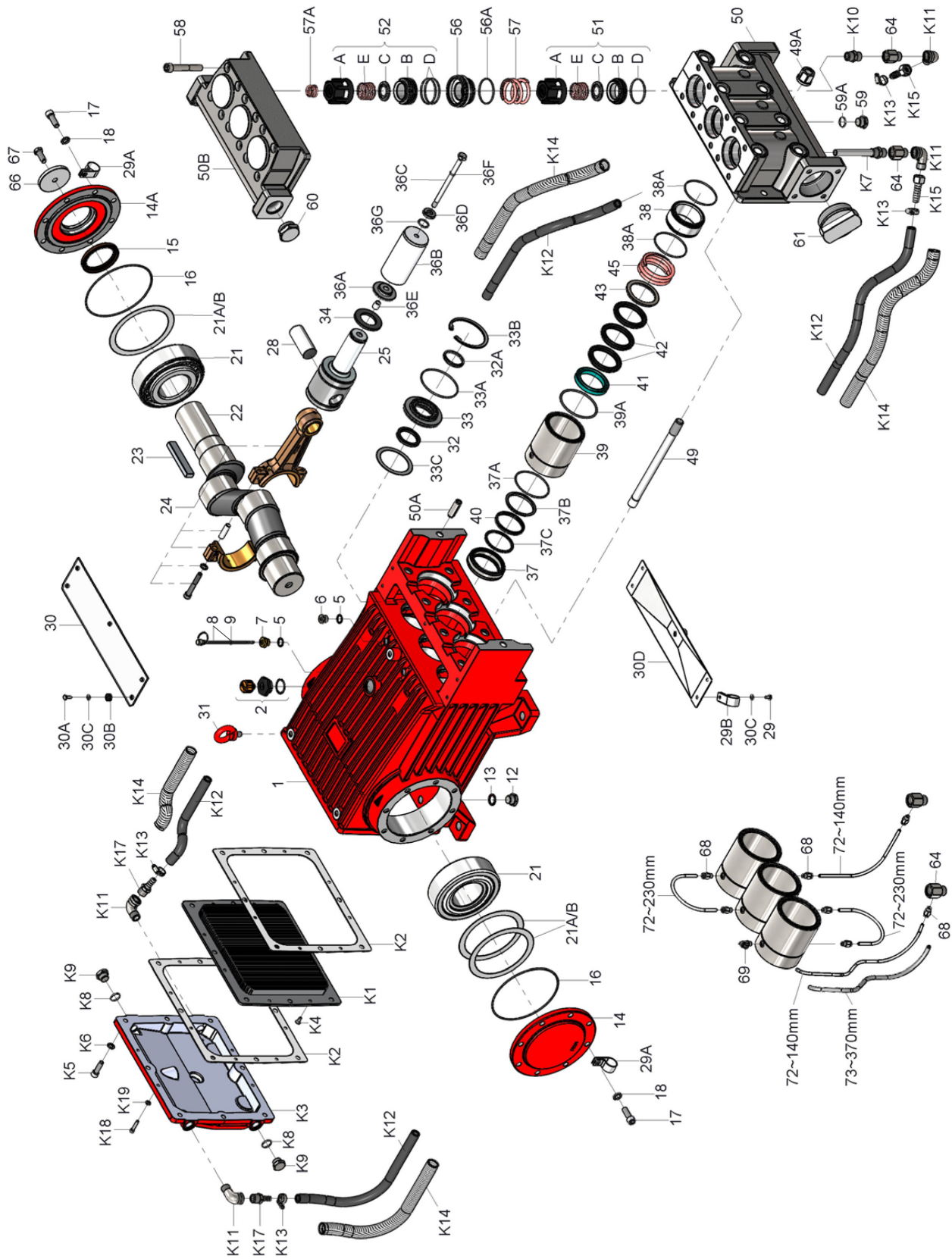

Part List - GP8065-5100

<u>Item</u>	<u>Part</u>	<u>Description</u>	<u>Qty</u>	<u>Item</u>	<u>Part</u>	<u>Description</u>	<u>Qty</u>
1	05380	Crankcase	1	42	06997	V Sleeve	9
2	06893	Oil Filler Plug Assy with Vent	1	43	05118-0100	Sleeve Support Ring	3
5	22929	Copper Washer	2	45	05119	Seal Tension Spring	3
6	04369	Plug, 3/8" BSP	1	49	05072	Stud Bolt	8
7	05656	Plug for oil dipstick	1	49A	03634	Hexagon Nut with Rim	8
8	05035*	Oil Dipstick Assembly	1	50	05074A-5000	Valve Casing	1
9	01009	O-Ring	1	50A	13162	Centering Stud	2
12	07109-0400	Plug 1/2" BSP	2	50B	05075-5000	Discharge Valve Casing	1
13	06272	Seal	2	51	05076-0100	Suction Valve Assembly	3
14	05036	Bearing Cover Closed	1	51A	04166	Spring Tension Cap	3
14A	05298	Bearing Cover Open	1	51B	05078-0100	Suction Valve Seat	3
15	05112	Radial Shaft Seal	1	51C	05079-0100	Valve Plate	3
16	05037	O-Ring	2	51D	07658-0001	O-Ring	3
17	05038	Hexagon Socket Screw	16	51E	05080	Valve Spring	3
18	05039	Spring Ring	16	52	05082-0100	Discharge Valve Assembly	3
21	05044	Tapered Roller Bearing	2	52A	04166	Spring Tension Cap	3
21A	05042	Fitting Disc	1-5	52B	05084-0100	Discharge Valve Seat	3
21B	05043	Fitting Disc	1-5	52C	05079-0100	Valve Plate	3
22	05299	Crankshaft	1	52D	05613	O-Ring	6
23	05300	Fitting Key	1	52E	05080	Valve Spring	3
24	05047	Connecting Rod Assembly	3	56	05085-0100	Discharge Valve Adaptor	3
25	05048	Crosshead c/w Plunger	3	56A	05613	O-Ring	3
28	05049	Crosshead Pin	3	57	05086	Pressure Spring	3
29	05051	Hexagon Screw	4	57A	07210-0100	Pressure Spring	3
29A	05381	Bracket 1 for Cooling Hose	2	58	05087-0100	Hexagon Socket Screw	12
29B	05383	Bracket 2 for Cooling Hose	2	59	07109-0400	Plug 1/2" BSP	1
30	05052	Cover Plate	1	59A	06807	Steel Seal	1
30A	07225-0100	Hexagon Screw	5	60	13151-0100	Plug 1-1/4" BSP	1
30B	13136	Grommet	5	61	05088-0100	Plug 3" BSP	1
30C	08280	Washer	9	64	03635	Adapter, 3/4" BSP to 1/2" BSP	2
30D	05050	Splash Cover	1	66	05303	Disc for Crankshaft	1
31	07623	Eye Bolt	3	67	13433	Hexagon Screw	1
32	05058	Radial Shaft Seal	3	68	04785	Push-In Fitting	7
32A	03118	Scraper	3	69	03440	Elbow Straight Screw Fitting	1
33	03119	Seal Retainer	3	72	03636	Hose	1
33A	05056	O-Ring	3	73	03442	Spiral Hose	1
33B	05054	Clip Ring	3	78	05025-0100	Oil Cooler Assembly	1
33C	05059	Fitting Disc	3	K1	05026-0100	Cooling Vane Plate	1
34	05060	Oil Shield	3	K2	05027	Seal for Gear Cover	2
36A	05063-0100	Cover for Plunger Pipe	3	K3	05028-0100	Gear Cover	1
36B	05115	Plunger Pipe	3	K4	05029	Hexagon Head Countersunk Screw	8
36C	03621	Tension Screw	3				
36D	07665-0100	Steel Washer	3	K5	07381-0100	Hexagon Socket Screw	6
36E	06900	Centering Sleeve	3	K6	08041	Washer	6
36F	05615	O-Ring	3	K7	05030-0100	Connection for Oil Cooler	1
36G	02026-0001	O-Ring	3	K8	06807	Steel Ring	2
37	03630	Seal Retainer	3	K9	07109-0400	Plug 1/2" BSP	2
37A	05619	O-Ring	3	K10	05031-0100	Connecting Branch	1
37B	03631	Support Ring	3	K11	05032-0100	Hose Adaptor	4
37C	03632	Scraper	3	K12	05033-0100	Tube for Cooler	2
38	05064-0100	Seal Case	3	K13	05402-0100	Hose Clamp	4
38A	06667-0001	O-Ring	6	K14	05403-0100	Hose Guard	2
39	05116-0100	Seal Sleeve	3	K15	05404-0100	Hose Coupling Nut	2
39A	05066	O-Ring	3	K17	03637	Hose Screw Joint	2
40	03633	Grooved Seal	3	K18	04158-0100	Hexagon Socket Screw	4
41	05117-0100	Pressure Ring	3	K19	05053	Washer	4

GP8065-5100 PUMP REPAIR KITS

Plunger Packing Kit - #09586-0100

<u>Item</u>	<u>Part #</u>	<u>Description</u>	<u>Qty.</u>
37A	05619	O-Ring	3
38A	06667-0001	O-Ring	6
39A	05066	O-Ring	3
40	03633	Grooved Seal	3
42	06997	V-Sleeve	9

Inlet Valve Kit - #09587-0100

<u>Item</u>	<u>Part #</u>	<u>Description</u>	<u>Qty.</u>
51	05076-0100	Inlet Valve Assembly	3
56A	05613	O-Ring	3

Oil Seal Kit - #09584A

<u>Item</u>	<u>Part #</u>	<u>Description</u>	<u>Qty.</u>
32	05058	Radial Shaft Seal	3
32A	03118	Scraper	3
33A	05056	O-Ring	3

Discharge Valve Kit - #09588-0100

<u>Item</u>	<u>Part #</u>	<u>Description</u>	<u>Qty.</u>
52	05082-0100	Discharge Valve Assembly	3
56A	05613	O-Ring	3

GP8065-5100 PUMP REPAIR INSTRUCTIONS

Maintenance and Servicing

For the type of threadlocker used and the required tightening torques, see page 7.

Special tools required

The following special tools are required for assembly:

- Assembling tool (p/n 07662)

Suction and Discharge Valves

Remove plugs (58), lift discharge casing (50B) up and away. Take out pressure springs (57A). Pull out assembled valves (51 and 52) with fitting tool (07662).

Dismantling valves: The spring tension cap (51A, 52A) is screwed together with the valve seat (51B or alternatively 52B). Remove spring tension cap, take out springs (51E, 52E) and valve plate (51C, 52C). Check sealing surfaces and O-rings (51D, 52D).

Replace worn parts.

Before refitting the valves, clean the sealing surfaces in the casing and check for any damage. Tighten screws (58) to the required torque; check torque tension after 8-10 operating hours.

Seals and Plunger

Loosen the hexagon nuts (49A) and pull the pump head (50) with the seal case (38) from the seal sleeve (39). If necessary, carefully tap the valve housing (50) off the centring stud (50A) using a rubber mallet

Pull the seal case (38) out of the valve casing (50); using two screwdrivers, it can be positioned into the front O-ring groove to be levered out of the valve casing. Examine O-rings (38A) and coat with silicon grease before fitting.



If necessary, support the pump head by resting it on wooden blocks or by using a pulley.

Loosen the tensioning screw (36C) and remove the plunger pipe (36B) from the seal unit; check for damage. Use a screw drive to pry sleeves (42) out of seal sleeve (39) and seal retainer (37).



Ensure that the seal sleeve (39), seal retainer (37) and pressure ring (41) are not damaged. Check the O-rings on the seal sleeve (39) and replace (if necessary).

Check the pressure rings and scraper (37C/41) for wear on the inside diameter and, if necessary, replace with the seals (40/42). Clean all parts and apply a thin layer of silicone grease to new parts before reassembly.

Fit the O-ring (37A) onto the seal retainer (37). Insert the scraper (37C), grooved seal (40) and support ring (37B) into the seal retainer (37).

Carefully push the ceramic pipe through the seals from the rear. If necessary, hold it from the front with a suitable piece of pipe (assembly tool) in position 37. Coat the cover (36A) for the plunger pipe (36B) on the step with silicone grease and place it on the rear end of the plunger pipe.

Insert the preassembled unit of components into the guide in the crankcase (1). Lightly coat the seal retainer (37) with anti-corrosion grease (e.g. Molykote no. Cu-7439) in its fitted area towards the crankcase.

Fit o-rings (36F, G) into the steel ring (36D) and push these past the tension screw (36C). Lightly coat tension screw (36C) with bonding agent and, together with steel ring, place into the ceramic pipe (36B).

Turn the pump manually until the plunger (25) touches against the plunger pipe. Tighten tension screw to the required torque.



Thread glue must never come between the plunger pipe (36B) and plunger cover (36A). Overtensioning of the plunger pipe by excessive tightening of the tension screw and/or dirt or damage on the mounting surfaces can lead to plunger pipe breakage.

Fit the o-ring (39A) onto the sealing sleeve (39). Insert the pressure ring (41) and sleeves (42) into the seal sleeve (39) via the ceramic plunger (36B). Insert the support ring (43) and seal tensioning spring (45) into the seal sleeve. Fit the sleeve support ring and spring (45).

Mounting Valve Casing:

Press the seal retainer (38) with pre-assembled O-rings (38A) into the center of the valve casing (50). Carefully push the valve body onto the dowel pins (50A).

Tighten the hexagon nuts (49A) evenly crosswise to the required torque.



The torque tension on the screws (49A) must be checked after 8-10 operating hours; the pump must be at zero pressure. Thereafter the tension is to be checked every 200 operating hours.



Mounting surfaces of the crankcase and valve casing must be clean and free of damage. The components must lie exactly and evenly on one another. The same exactness applies for all centring positions in the crankcase, pressure and valve casing.

If required, supplementary assembly instructions can be requested from the manufacturer Giant Industries, Inc.

GP8065-5100 SERIES DIMENSIONS - Inches (mm)

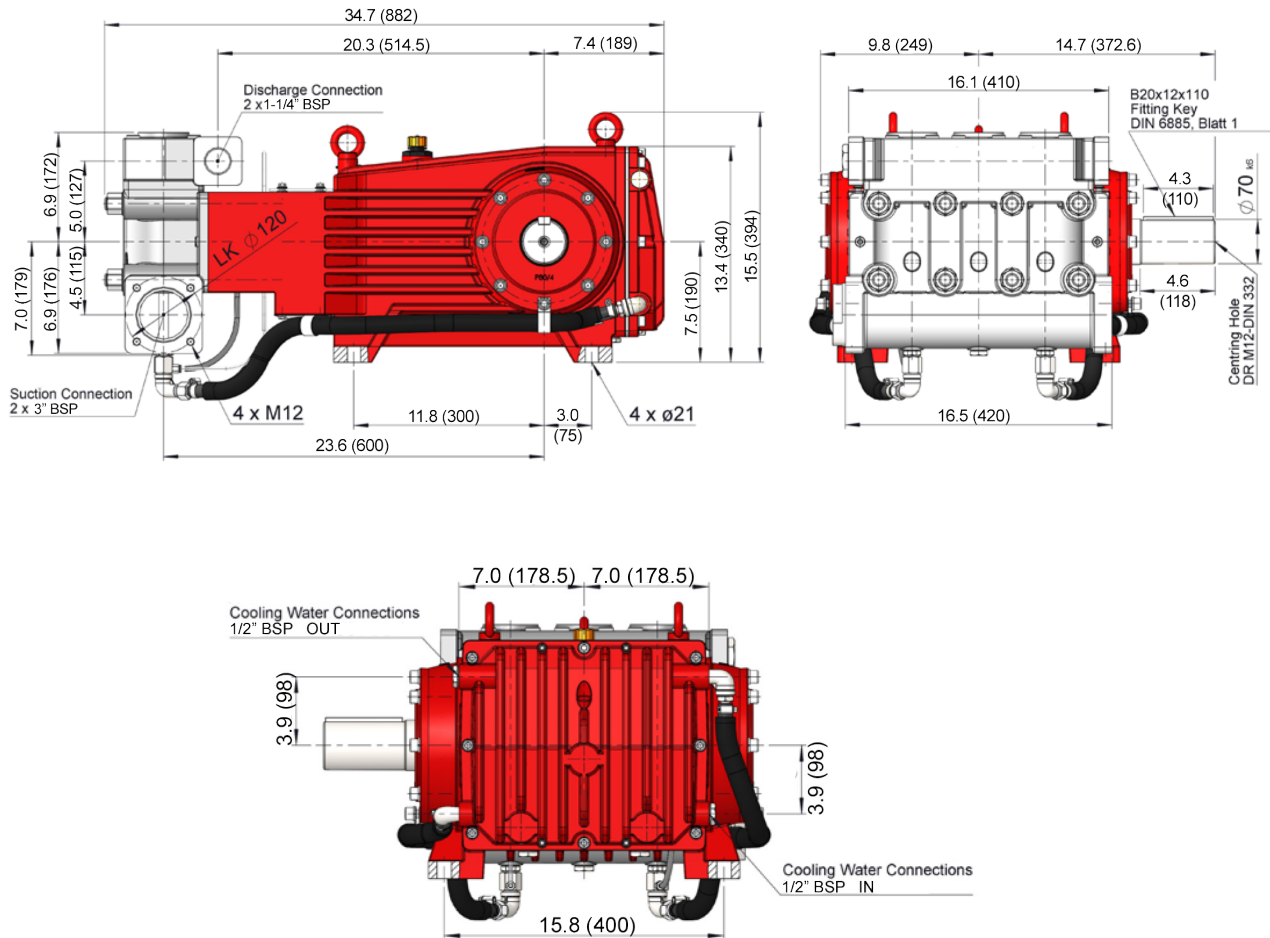

GP8065-5100 Torque Specifications				
Item	Thread	Tool Needed	Lubrication Info	Torque Amount
12	1/2" BSP			59 ft.-lbs. (80 Nm)
15			Loctite 403	
17	M12	10mm allen wrench		64 ft.-lbs. (87 Nm)
24	M10	8mm allen wrench		37 ft.-lbs. (50 Nm)
32			Loctite 403	
36C	M10	19mm socket		30 ft.-lbs. (40 Nm)
39			Anti Seize 350 (Crankcase outside)	
49	M20		Loctite 648 (crankcase side)	
49A	M20	30mm socket		265 ft.-lbs. (360 Nm)
51B			Anti-Seize CU-7439	
52B			Anti-Seize CU-7439	
58	M14	12mm allen wrench	Anti-Seize 350	133 ft.-lbs. (180 Nm)
59	1/2" BSP			59 ft.-lbs. (80 Nm)
K4	M6			11 ft.-lbs. (15 Nm)
K5	M10	8mm allen wrench		33 ft.-lbs. (45 Nm)
K9	1/2" BSP			59 ft.-lbs. (80 Nm)
K18	M6			11 ft.-lbs. (15 Nm)

GIANT INDUSTRIES LIMITED WARRANTY

Giant Industries, Inc. pumps and accessories are warranted by the manufacturer to be free from defects in workmanship and material as follows:

1. Five (5) years from the date of shipment for all pumps used in portable pressure washers with NON-SALINE, clean water applications.
2. Two (2) years from the date of shipment for Giant pumps used in car wash applications.
3. One (1) year from the date of shipment for all other Giant industrial and consumer pumps.
4. Six (6) months from the date of shipment for all rebuilt pumps
5. Ninety (90) days from the date of shipment for all Giant accessories.

This warranty is limited to repair or replacement of pumps and accessories of which the manufacturer's evaluation shows were defective at the time of shipment by the manufacturer. The following items are NOT covered or will void the warranty:

1. Defects caused by negligence or fault of the buyer or third party.
2. Normal wear and tear to standard wear parts.
3. Use of repair parts other than those manufactured or authorized by Giant.
4. Improper use of the product as a component part.
5. Changes or modifications made by the customer or third party.
6. The operation of pumps and or accessories exceeding the specifications set forth in the Operations Manuals provided by Giant Industries, Inc.

Liability under this warranty is on all non-wear parts and limited to the replacement or repair of those products returned freight prepaid to Giant Industries which are deemed to be defective due to workmanship or failure of material. A Returned Goods Authorization (R.G.A.) number and completed warranty evaluation form is required prior to the return to Giant Industries of all products under warranty consideration. Call (419)-531-4600 or fax (419)-531-6836 to obtain an R.G.A. number.

Repair or replacement of defective products as provided is the sole and exclusive remedy provided hereunder and the MANUFACTURER SHALL NOT BE LIABLE FOR FURTHER LOSS, DAMAGES, OR EXPENSES, INCLUDING INCIDENTAL AND CONSEQUENTIAL DAMAGES DIRECTLY OR INDIRECTLY ARISING FROM THE SALE OR USE OF THIS PRODUCT.

THE LIMITED WARRANTY SET FORTH HEREIN IS IN LIEU OF ALL OTHER WARRANTIES OR REPRESENTATION, EXPRESS OR IMPLIED, INCLUDING WITHOUT LIMITATION ANY WARRANTIES OR MERCHANTABILITY OR FITNESS FOR A PARTICULAR PURPOSE AND ALL SUCH WARRANTIES ARE HEREBY DISCLAIMED AND EXCLUDED BY THE MANUFACTURER.



WARNING: This product might contain a chemical known to the State of California to cause cancer, and birth defects or other reproductive harm.
For more information go to www.P65Warnings.ca.gov

GIANT
Performance Under Pressure

GIANT INDUSTRIES, INC., 900 N. Westwood Ave., Toledo, Ohio 43607
PHONE (419) 531-4600, FAX (419) 531-6836, www.giantpumps.com
© Copyright 2024 Giant Industries, Inc.