

Model

GP8065HT-1000

Triplex Ceramic
Plunger Pump
Models Manual

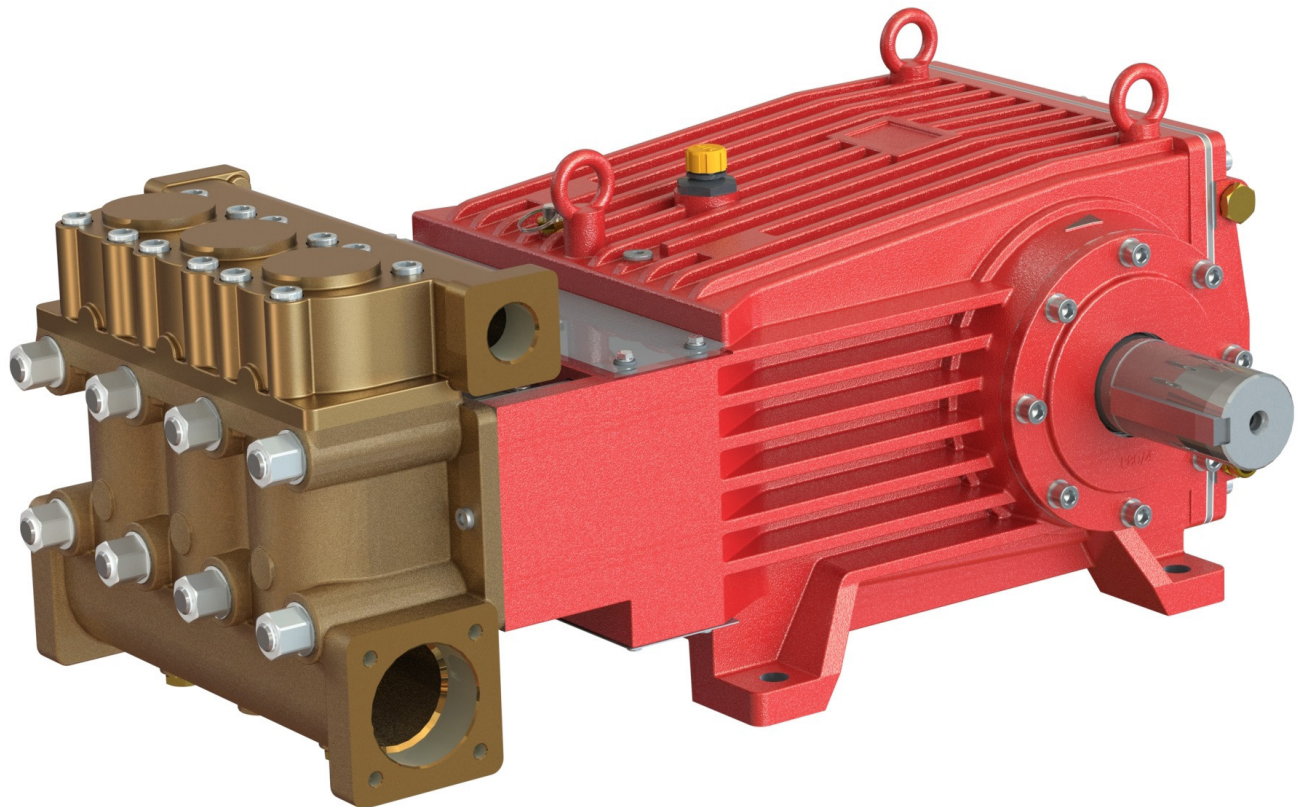

Contents:	
Installation Instructions:	page 2
Pump Specifications:	page 3
Exploded View:	page 4
Parts List:	page 5
Repair Kits/Torque Specifications:	page 6
Repair Instructions:	page 7
Dimensions:	back page
Warranty Information	back page

INSTALLATION INSTRUCTIONS

Operation and Maintenance

Check oil level prior to starting and ensure trouble-free water supply.

Oil amount: 4 gallons (15 litres). Only use ISO VG 220 industrial gear oil (e.g. Aral Degol BG220) or automobile gear oil SAE 90 GL4 (Giant's p/n 01154). Initial change after 50 operating hours and then every 1000 operating hours, or after 1 year if used less.

IMPORTANT! Care must be taken when operating in damp places or with high temperature fluctuations. Oil must be changed immediately should condensate (frothy oil) occur in the gear box.

IMPORTANT! When setting up the pump, note carefully the arrow on the side of the crankcase which shows the recommended direction of rotation. The preferred direction of rotation ensures the motion of the conrods correctly distributes oil onto the crosshead guides – which is a particular advantage where continuous operation is involved.

IMPORTANT! The torque tension on the valve casing nuts (49A) is to be checked after approximately 200 operating hours. Please see page 6 concerning the torque values. The pump must be at zero pressure when checking the torque tension.

IMPORTANT! Gear oil cooling: the pump can normally be run in continuous operation without oil cooling up to a power of 73.8 HP (55 kW). However, the oil temperature in the crankcase must not rise above 167 °F (75°C) in this case. External oil cooling may be necessary depending on ambient temperatures, on the temperature of the medium and on heat transfer to the environment. External cooling can be set up using the ½" input connection (K10) on the bottom of the crankcase cover and the corresponding diagonal ½" output connection (K10) on the top of the crankcase cover through which cooling water can be feed. Its flow amount depends on the temperature of the cooling water and ambient temperatures. We recommend a cooling capacity of 1.3 to 2 HP (1 to 1.5 kW).

IMPORTANT! A closed circuit can be fitted for cooling. The system pressure in such a closed cooling circuit must not exceed 29 PSI (2 bar).

Plant Lay-Out

For correct functioning of the pump, the following points must be respected:

a) Pressure on Suction Side

The stipulated NPSHR is the minimum required pressure above the vapour pressure of the medium and is never to fall short of this figure. Temperature and vapour pressure of the medium, the geodetic height of the location, the flow rate and loss of friction in the suction line must all be taken into consideration. It may be necessary to fit a booster pump (centrifugal pump) in the suction line.

b) Pulsation

Due to its construction, the plunger pump creates pulsation in the suction and discharge lines. Suction pulsation in particular must be damped in order to prevent resonance in the suction line which in turn causes cavitation. Therefore the pump is never to be connected to a rigid pipe, but instead to a flexible hose (not reinforced by steel), and if possible 1.5 to 2 times wider than the suction connection. If a booster pump is used, the hose is to be attached between the booster pump and the high pressure pump.

If several pumps are used, each pump must have its own suction line. If this cannot be done, a suction air chamber or a suction flow stabilizer must be installed in front of each pump. The bladder in the stabilizer is to be charged on location.

Depending on the layout of the plant, a pressure accumulator may be necessary on the discharge side. This pressure accumulator must be fitted directly in front of the discharge outlet of the high pressure pump. We recommend the use of only one pressure accumulator respectively in the discharge line in order to avoid irritation which could be caused by different pre-tension levels in the accumulators.

Gas tension in both the suction flow stabilizer/s and in the pressure accumulator/s should be checked regularly.

Specifications

Model GP8065HT-1000

	U.S.	(Metric)
Flow	75.3 GPM	(285 LPM)
Discharge Pressure	1500 PSI	(100 bar)
Power Consumption	73.7 BHP	55 kW
Maximum Speed.....		420 RPM
Inlet Pressure.....	29 PSI	(2.0 bar)
Plunger Diameter.....	2.55"	65 mm
Plunger Stroke	2.83"	72 mm
Crankshaft Diameter.....	2.76"	70 mm
Key Width	0.55"	14 mm
Crankshaft Mounting.....		Either side
Shaft Rotation		Top of pulley towards manifold
Temperature of Pumped Fluids.....	Up to 221 °F	(105 °C)
Inlet Ports.....		(2) 3" BSP
Discharge Ports		(2) 1-1/4" BSP
Weight.....	749 lbs.	(340 kg)
Crankcase Oil Capacity	4.0 Gal.	(15 liters)
Valve Casing Material		Aluminum Bronze
NPSHR	23.0 ft.-head	7.0 mWs

Consult the factory for special requirements that must be met if the pump is to operate beyond one or more of the limits specified above.

GP8065HT-1000					
HORSEPOWER REQUIREMENTS					
RPM	GPM	500 PSI	750 PSI	1000 PSI	1500 PSI
210	37.7	13.0	19.5	26.0	39.0
300	53.8	18.6	27.8	37.1	55.7
350	62.8	21.7	32.5	43.3	65.0
420	75.3	26.0	39.0	51.9	77.9

SPECIAL NOTE:

The theoretical gallons per revolution (gal/rev) is 0.179. To find specific outputs at various RPM, use the formula:

$$\text{GPM} = 0.179 \times \text{RPM}$$

HORSEPOWER RATINGS:

The rating shown are the power requirements for the pump. Gas engine power outputs must be approximately twice the pump power requirements shown above.

We recommend a 1.15 service factor be specified when selecting an electric motor as the power source. To compute specific pump horsepower requirements, use the following formula:

$$\frac{\text{GPM} \times \text{PSI}}{1450} = \text{HP}$$

Exploded View - GP8065HT-1000

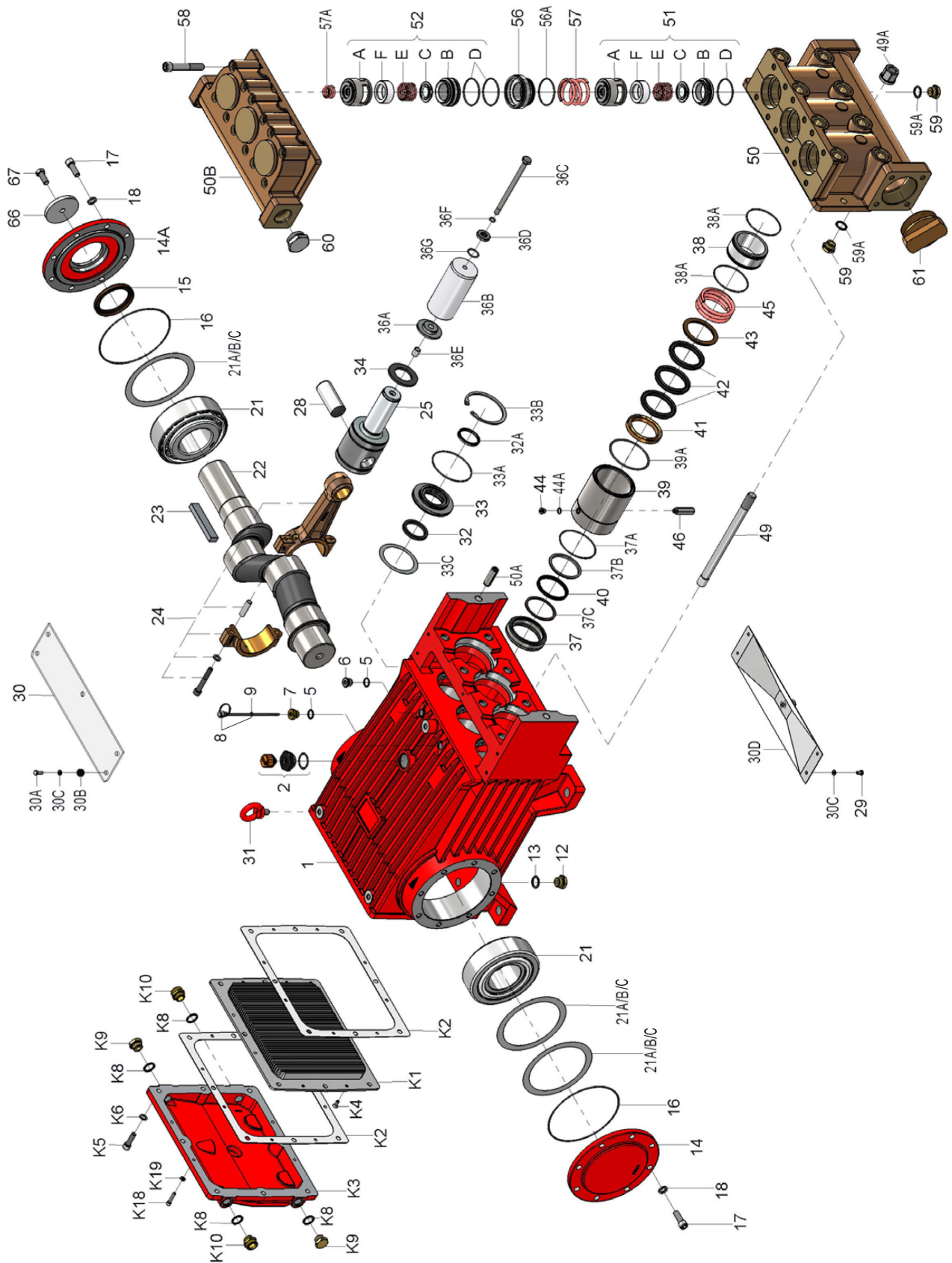

Part List - GP8065HT-1000

<u>Item</u>	<u>Part</u>	<u>Description</u>	<u>Qty</u>	<u>Item</u>	<u>Part</u>	<u>Description</u>	<u>Qty</u>
1	05380	Crankcase	1	39A	05066	O-Ring	3
2	06893	Oil Filler Plug Assy with Vent	1	40	03641	Seal Ring	3
5	22929	Copper Washer	2	41	03642	Pressure Ring	3
6	12256	Plug, 3/8" BSP	1	42	06997-0030	V Sleeve	9
7	05656	Plug for oil dipstick	1	43	05118	Sleeve Support Ring	3
8	05035	Oil Dipstick Assembly	1	44	06589	Socket Plug, 1/8" BSP	3
9	01009	O-Ring	1	44A	06709	Seal	3
12	07109	Plug 1/2" BSP	2	45	05119	Seal Tension Spring	3
13	06272	Seal	2	46	05169	Threaded Pipe	3
14	05036	Bearing Cover Closed	1	49	05072	Stud Bolt	8
14A	05298	Bearing Cover Open	1	49A	05073	Hexagon Nut	8
15	05112	Radial Shaft Seal	1	50	05074-3000	Valve Casing	1
16	05037	O-Ring	2	50A	13162	Centering Stud	2
17	05038	Hexagon Socket Screw	16	50B	05075-3000	Discharge Valve Casing	1
18	05039	Spring Ring	16	51	05076	Suction Valve Assembly	3
21	05044	Tapered Roller Bearing	2	51A	05077	Spring Tension Cap	3
21A	05042	Fitting Disc	1-5	51B	05078	Suction Valve Seat	3
21B	05043	Fitting Disc	1-5	51C	05079	Valve Plate	3
21C	05113	Fitting Disc	1-5	51D	07658-0001	O-Ring	3
22	05299	Crankshaft	1	51E	05080	Valve Spring	3
23	05300	Fitting Key	1	51F	05081	Valve Spring Guide	3
24	05047	Connecting Rod Assembly	3	52	05082	Discharge Valve Assembly	3
25	05048	Crosshead c/w Plunger	3	52A	05077	Spring Tension Cap	3
28	05049	Crosshead Pin	3	52B	05084	Discharge Valve Seat	3
29	05051	Hexagon Screw	4	52C	05079	Valve Plate	3
30	05052	Cover Plate	1	52D	05613	O-Ring	6
30A	07225-0100	Hexagon Screw	5	52E	05080	Valve Spring	3
30B	13136	Grommet	5	52F	05081	Valve Spring Guide	3
30C	08280	Washer	10	56	05085	Discharge Valve Adaptor	3
30D	05050	Splash Cover	1	56A	05613	O-Ring	3
31	07623	Eye Bolt	3	57	05086	Pressure Spring	3
32	05058	Radial Shaft Seal	3	57A	07210-0100	Pressure Spring	3
32A	03118	Scraper	3	58	05087	Hexagon Socket Screw	12
33	03119	Seal Retainer	3	59	07109	Plug 1/2" BSP	4
33A	05056	O-Ring	3	59A	06272	Copper Seal	4
33B	05054	Clip Ring	3	60	06909	Plug 1-1/4" BSP	1
33C	05059	Fitting Disc	3	61	05088	Plug 3" BSP	1
34	05060	Oil Shield	3	66	05303	Disc for Crankshaft	1
36A	05063	Cover for Plunger Pipe	3	67	13433	Hexagon Screw	1
36B	05115	Plunger Pipe	3	78	03612	Oil Cooler Assembly	1
36C	03562	Tension Screw	3	K1	05026	Cooling Vane Plate	1
36D	03577	Copper Washer	3	K2	05027	Seal for Gear Cover	2
36E	06900	Centering Sleeve	3	K3	05028	Gear Cover	1
36F	05615	O-Ring	3	K4	05029	Hexagon Head Countersunk Screw	8
36G	02026-0001	O-Ring	3	K5	07381	Hexagon Socket Screw	6
37	03638	Seal Retainer	3	K6	08041	Washer	6
37A	05619	O-Ring	3	K8	06272	Copper Seal	4
37B	03639	Support Disc	3	K9	07109	Plug 1/2" BSP	2
37C	03640	Scraper	3	K10	05031	Connecting Branch	2
38	05064	Seal Case	3	K18	04158	Hexagon Socket Screw	4
38A	06667-0001	O-Ring	6	K19	05053	Washer	4
39	03643	Seal Sleeve	3				

GP8065HT-1000 PUMP REPAIR KITS

Plunger Packing Kit

#09586-0030

Item	Part #	Description	Qty.
38A	06667-0001	O-Ring	6
39A	05066	O-Ring	3
40	03641	Seal Ring	3
42	06997-0030	V-Sleeve	9

Inlet Valve Kit - #09587-0030

Item	Part #	Description	Qty.
51	05076	Inlet Valve Assembly	3
56A	05613	O-Ring	3

Discharge Valve Kit - #09588-0030

Item	Part #	Description	Qty.
52	05077	Discharge Valve Assy	3
56A	05613	O-Ring	3

Oil Seal Kit - #09584A

Item	Part #	Description	Qty.
32	05058	Radial Shaft Seal	3
32A	03118	Scraper	3
33A	05056	O-Ring	3

GP8065HT-1000 Torque Specifications					
Item	Part #	Description	Thread	Lubrication Info	Torque Amount
12	07109	Plug	1/2" BSP		59 ft.-lbs. (80 Nm)
15	05112	Radial Shaft Seal		Loctite 403	
17	05038	Hexagon Socket Screw	M12		64 ft.lbs. (87 Nm)
24	05047	Connecting Rod Assembly	M10		37 ft.lbs. (50 Nm)
32	05058	Radial Shaft Seal		Loctite 403	
36C	03562	Tension Screw	M10		29.5 ft.-lbs. (40 Nm)
39	03643	Seal Sleeve		Anti Seize 350 (Crankcase outside)	
49	05072	Stud Bolt	M20	Loctite 648 (Crankcase side)	
49A	05073	Hexagon Nut	M20		265 ft.-lbs. (360 Nm)
58	05087	Hexagon Socket Screw	M14	Anti-Seize 350	133 ft.-lbs. (180 Nm)
59	07109	Plug	1/2" BSP		59 ft.-lbs. (80 Nm)
K4	05029	Hexagon Head Counter-sunk Screw	M6		11 ft.-lbs. (15 Nm)
K5	07381	Hexagon Socket Screw	M10		33 ft.-lbs. (45 Nm)
K9	07109	Plug	1/2" BSP		59 ft.-lbs. (80 Nm)
K18	04158	Hexagon Socket Screw	M6		11 ft.-lbs. (15 Nm)

GP8065HT-1000 PUMP REPAIR INSTRUCTIONS

To Check Valves

Screw out plugs (58), lift discharge casing (50B) up and away. Take out pressure springs (57A). Pull out assembled valves (51 and 52) with fitting tool (p/n 07662).

Dismantling valves: The spring tension cap (51A, 52A) is screwed together with the valve seat (51B or alternatively 52B). Remove spring tension cap, take out springs (51E, 52E) and valve plate (51C, 52C). Check sealing surfaces and O-rings (51D, 52D). Replace worn parts.

When reassembling, coat threads of valve seat with silicone grease or Molycote anti-seize Cu-7439. Before refitting the valves, clean the sealing surfaces in the casing and check for any damage.

Tighten screws (58) at 133 ft.-lbs. (180 Nm); check torque tension after 8-10 operating hours.

To Check Seals and Plunger Pipe

Remove hexagon nuts (49A), remove valve casing (50) together with seal case (38) from crankcase (1). If necessary, carefully tap the valve casing past the centring stud (50A) using a rubber hammer.

IMPORTANT! If necessary, support the pump head by resting it on wooden blocks or by using a pulley. Remove tension screw (36C) and take seal sleeve (39) together with all mounted parts out of the drive. Pull plunger pipe out of the seal assembly and check all parts for damage. Lever seal rings (40), sleeves (42) and pressure rings (41) out of the seal sleeve with a screwdriver.

IMPORTANT! Be careful not to damage seal sleeve (39) and pressure ring (41). Check the inner diameter of the pressure ring for wear and if necessary replace together with sleeves (42). Clean all parts. New parts should be lightly coated with silicon grease before fitting.

Press seal unit (41, 42, 43) into the sleeve and place grooved seal (40) in seal retainer (37).

Important: When fitting, do not bend the grooved seal (40). Press it in straight using a suitable rod or pipe. Push the ceramic plunger carefully through the seals from the crankcase side. If necessary, the high pressure seals can be held tightly by also using a suitable rod or pipe held on the other side.

Take seal case (38) out of the valve casing (50) and examine O-rings (38A). If necessary, place 2 screwdrivers in the front O-ring groove. Coat seals with silicon grease before fitting.

IMPORTANT! Mounting surfaces of the crankcase and valve casing must be clean and free of damage. The components must lie exactly and evenly on one another. The same exactness applies for all centring positions in the crankcase, pressure casing and valve casing.

Coat the seal sleeve lightly with anti-corrosive grease (e.g. molycote no. Cu-7439) in its fitted area towards the crankcase. Insert seal sleeves (39) into their crankcase fittings. Coat the threads of the tension screw (36C) lightly with thread glue and insert it together with new O-rings (36F, G) through the ceramic pipe. Turn the pump by hand until the plunger (25) rests against the plunger pipe. Tighten tension screw at 29.5 ft.-lbs. (40 Nm).

IMPORTANT! Thread glue must never come between the plunger pipe (36B) and centring sleeve (36E).

Overtensioning of the plunger pipe by excessive tightening of the tension screw and/or dirt or damage on the mounting surfaces can lead to breakage of the plunger pipe.

Insert the seal tension spring (45) and O-ring (39A) into the seal sleeve (39).

Mounting the Valve Casing:

Put seal cases (38) in the centring holes of the valve casing, then push the valve casing carefully onto centring studs (50A). Tighten hexagon screws (49A) evenly and crosswise at 265 ft.-lbs. (360 Nm).

IMPORTANT! The torque tension on the screws (49A) must be checked after 8-10 operating hours when the pump is at zero pressure. Thereafter the tension is to be checked every 200 operating hours.

To Dismantle Crankcase Gear

Take out plungers and seal sleeves as described above. Drain oil by removing plug (12).

After removing clip ring (33B), lever out the seal retainer (33) with a screwdriver. Remove connecting rod screws (24).

IMPORTANT! Connecting rods are marked 1 to 3 for identification. Do not twist connecting rod halves or interchange them. When reassembling, the connecting rods must be fitted in their exact original position on the crankshaft journals.

Push connecting rod halves together with the crosshead as far as possible into the crosshead guide.

Take off bearing cover (14/14A) and push out the crankshaft (22) from the drive side, taking particular care not to bend the connecting rods.

Check surfaces on the connecting rods (24), crankshaft and crossheads (25). Check the surfaces of the crosshead guides in the crankcase for any unevenness.

Reassemble in reverse order.

Mount connecting rod halves in their exact original position and tighten at 37 ft.-lbs. (50 Nm). Press in the bearing outer ring (from 21) on the drive side and fit the bearing cover. Then from the opposite side, thread the crankshaft together with both bearing inner rings (from 21) with the long end first through the bearing bores.

IMPORTANT! When threading the shaft through the radial shaft seal in the bearing cover, be careful that the keyway on the shaft does not damage the lip of the radial shaft seal.

Press in the second bearing outer ring (from 21). Fit the shims and bearing cover and check axial play on the crankshaft. Place shims until the crankshaft turns easily with very little play.

IMPORTANT! A little clearance must exist to enable slight sideward movement of the connecting rod on its journal.

Fit bearing cover (14A) and tighten screws (17) at 64 ft.-lbs. (87 Nm).

Adjust axial play (clearance) on the crankshaft to minimum 0.1 mm / max. 0.15 mm using shims (21A/21B). The shaft should turn easily with little clearance. Connecting rods must sit exactly in the middle of each crank pin. Fit bearing cover (14) and tighten the screws (17) at 64 ft.-lbs. (87 Nm).

IMPORTANT! Possible axial float of the seal adaptor (33) is to be compensated with shims (33C). Fit crankcase cover (K3) together with its seal (K2).

GP8065HT-1000 SERIES DIMENSIONS - Inches (mm)

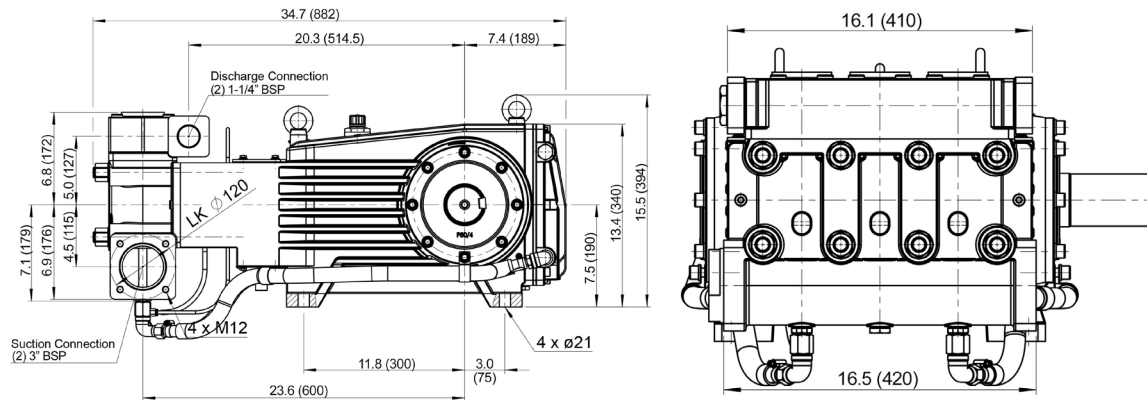

GIANT INDUSTRIES LIMITED WARRANTY

Giant Industries, Inc. pumps and accessories are warranted by the manufacturer to be free from defects in workmanship and material as follows:

1. Five (5) years from the date of shipment for all pumps used in portable pressure washers with NON-SALINE, clean water applications.
2. Two (2) years from the date of shipment for Giant pumps used in car wash applications.
3. One (1) year from the date of shipment for all other Giant industrial and consumer pumps.
4. Six (6) months from the date of shipment for all rebuilt pumps
5. Ninety (90) days from the date of shipment for all Giant accessories.

This warranty is limited to repair or replacement of pumps and accessories of which the manufacturer's evaluation shows were defective at the time of shipment by the manufacturer. The following items are NOT covered or will void the warranty:

1. Defects caused by negligence or fault of the buyer or third party.
2. Normal wear and tear to standard wear parts.
3. Use of repair parts other than those manufactured or authorized by Giant.
4. Improper use of the product as a component part.
5. Changes or modifications made by the customer or third party.
6. The operation of pumps and or accessories exceeding the specifications set forth in the Operations Manuals provided by Giant Industries, Inc.

Liability under this warranty is on all non-wear parts and limited to the replacement or repair of those products returned freight prepaid to Giant Industries which are deemed to be defective due to workmanship or failure of material. A Returned Goods Authorization (R.G.A.) number and completed warranty evaluation form is required prior to the return to Giant Industries of all products under warranty consideration. Call (419)-531-4600 or fax (419)-531-6836 to obtain an R.G.A. number.

Repair or replacement of defective products as provided is the sole and exclusive remedy provided hereunder and the MANUFACTURER SHALL NOT BE LIABLE FOR FURTHER LOSS, DAMAGES, OR EXPENSES, INCLUDING INCIDENTAL AND CONSEQUENTIAL DAMAGES DIRECTLY OR INDIRECTLY ARISING FROM THE SALE OR USE OF THIS PRODUCT.

THE LIMITED WARRANTY SET FORTH HEREIN IS IN LIEU OF ALL OTHER WARRANTIES OR REPRESENTATION, EXPRESS OR IMPLIED, INCLUDING WITHOUT LIMITATION ANY WARRANTIES OR MERCHANTABILITY OR FITNESS FOR A PARTICULAR PURPOSE AND ALL SUCH WARRANTIES ARE HEREBY DISCLAIMED AND EXCLUDED BY THE MANUFACTURER.



WARNING: This product might contain a chemical known to the State of California to cause cancer, and birth defects or other reproductive harm.
For more information go to www.P65Warnings.ca.gov

GIANT
Performance Under Pressure

GIANT INDUSTRIES, INC.

900 N. Westwood Ave.

Toledo, Ohio 43607

(419) 531-4600

FAX (419) 531-6836

www.giantpumps.com

© Copyright 2023 Giant Industries, Inc.