

Model GP8265

Triplex Ceramic
Plunger Pump
Models Manual

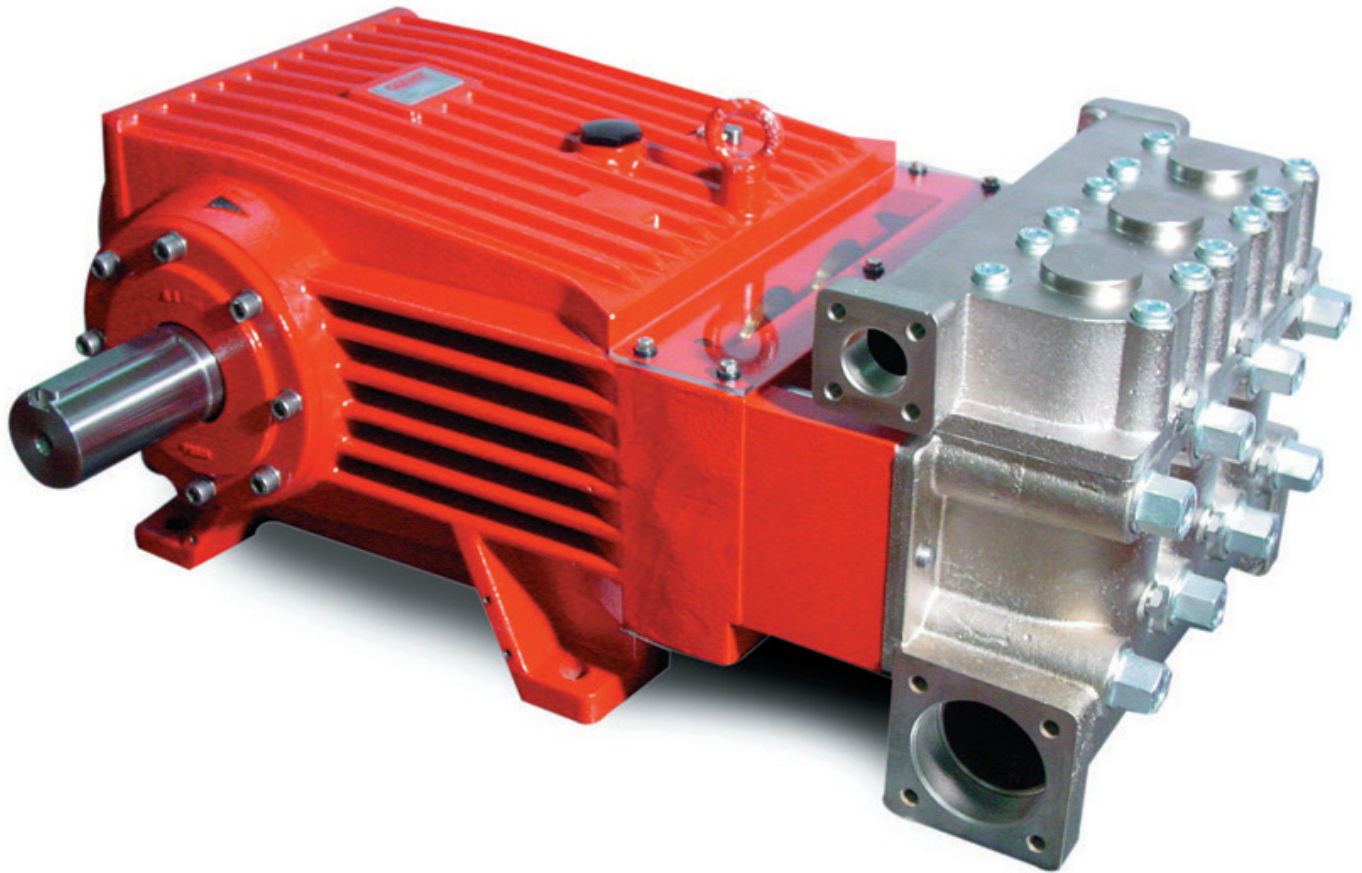

GIANT
Performance Under Pressure

Contents:

Installation Instructions:	page 2
Pump Specifications:	page 3-5
Exploded View/Parts List:	pages 6-7
Repair Kits/Tool List:/Torque Specifications	page 8
Troubleshooting Chart:	page 8
Repair Instructions:	pages 9-11
Dimensions:	back page
Warranty Information	back page

INSTALLATION INSTRUCTIONS

The stated figures are for maximum pressure and maximum speed (rpm) and apply for interval operation with cold water. Required NPSH refers to water (specific weight 1kg/dm³, viscosity 1°E) at maximum permissible pump revolutions. Fluid medium: Clean water filtered to 50µm.

Operation and Maintenance

Check oil level prior to starting and ensure trouble-free water supply.

IMPORTANT! If there is a danger of frost, the water in the pump and in the pump fittings (particularly the unloader valve) must be emptied. The second discharge port can also be used and the pump run "dry" for 1-2 minutes for this purpose. Oil: Use only 3.3 gallons (12.5 liters) of Giant Oil (p/n 01154) or ISO VG 220 GL4 (e.g. Aral Degol BG220) or SAE 90 GL4 gear oil. Initial change after 50 operating hours and then every 1000 operating hours or after one year of operation.

IMPORTANT! when operating in damp places or with high temperature fluctuations. Oil must be changed immediately should condensate (frothy oil) occur in the gear box.

NPSH values must be observed

Cooling the Gear Oil

IMPORTANT! When using the integrated cooling system for cooling the gear oil, the water inlet pressure must not exceed 29 PSI (2 bar).

If a separate cooling circuit is installed, it is then possible to have an inlet pressure up to a maximum of 145 PSI (10 bar) on the inlet side.

Make sure that suction pulsation is sufficiently dampened – water column resonance must be avoided.

IMPORTANT! The pumps can be run without gear oil cooling in continuous operation **up to a power rating of 107 hp (80 kW)** or with major intermittent operation at full performance (see below regarding the definition for intermittent operation). If operational power exceeds **107 hp (80 kW)** or if continuous operation is the case, the pump must be run with the integrated oil cooling system.

Definition of intermittent operation: operation at full performance for not more than 20 minutes in any given hour. In between the pump is running without pressure or turned off. For example, this can be full load operation for 5 minutes four times an hour with 10 minute breaks in between or continuous full load operation for 20 minutes followed by a 40 minute break.

The maximum temperature of the water being pumped and which is also fed through the cooling system must not exceed 86 °F (30 °C). The water amount which is fed into the cooling system depends on the pump speed and is approximately 1.85 gpm (7.0 l/min.) at 580 pump rpm. The cooling water is sucked in by one of the pumping chambers and pumped away.

IMPORTANT! If higher medium temperatures or liquids other than water are involved or aggressive media such as seawater, demineralised water etc., the pump must be fitted with a separate cooling circuit. The separate cooler must have a cooling efficiency of 1700 watt. If there is a danger of frost, an appropriate amount of antifreeze must be mixed into the cooling circuit.

When starting up for work, the pump must run first at zero pressure for approximately 1 minute.

IMPORTANT! The GP8000 series has a black arrow on the crankcase which shows the preferred direction of rotation. The preferred direction of rotation ensures oil is splashed onto the crosshead guides in the correct manner via the motion of the connecting rods – which is a particular advantage where

continuous operation is involved.

The pump can also be run against the recommended direction of rotation if operated periodically or at reduced pressure. If so, the pump must be run in in this direction to smoothen the bearing areas. This is done by initially operating the pump at zero pressure for 30 minutes; thereafter the pressure is to be slowly increased over a period of an hour to the desired maximum operating pressure. Check the oil temperature during this process.

IMPORTANT! If there is a danger of frost, the pump and cooling system must be emptied. Note that travel wind can cause water in pumps fitted on open vehicles to freeze even if the outside temperature is above freezing point.

To empty the cooling circuit, remove the L-joints (K11) on the pump head (50). Blow out the circuit liquid at the joint connection (K11/K7) using compressed air.

The torque tension on the valve casing nuts (49A) is to be checked after approximately 200 operating hours. Please see page 8 for torque specifications.

When checking the torque tension, the pump must be at zero pressure.

IMPORTANT! The service life of the seals is maximized if a minimal amount of leakage is present. A few drops of water can drip from each plunger every minute. Leakage has to be examined every day; the plunger seals must be changed should leakage become excessive i.e. constant dripping.



Safety Rules

The operating instructions must be read and adhered to before performing any work on the pump or complete assembled unit. No responsibility will be carried by us for damage to materials or persons caused by improper handling of our pumps.

Access to the pump is not allowed for unauthorized personnel. A safety valve is to be installed in accordance with the guidelines for liquid spraying units so that the admissible operating pressure cannot be exceeded by more than 10%. Pump operation without a safety valve as well as any excess in temperature or speed limits automatically voids the warranty.

When the pump is in operation, the driven shaft side and its coupling must be covered by a protective guard. The plunger area must also be covered by the protective plate (30).

Do not step onto the protective plate (30) or put weight on it. Pressure in the discharge line and pump must be at zero before carrying out any maintenance work to the pump or unit. Close off suction line. Disconnect fuses to ensure that the driving motor cannot be accidentally switched on. Make sure that the pump, the cooling system and all parts on the pressure side of the unit are vented and refilled, with pressure at zero, before starting the pump.

In order to prevent air or an air/water-mixture being absorbed and cavitation occurring, the pump npshr (net positive suction head required) and water temperature must be respected.

Cavitation and/or compression of gases lead to uncontrollable pressure-kicks which can ruin the pump and unit parts and also be dangerous to the operator or anyone standing nearby.

Giant plunger pumps are suitable for pumping clean water and other non-aggressive or non-abrasive media with a specific weight similar to water.

Before pumping other liquids - especially inflammable, explosive and toxic media - the pump manufacturer must be consulted with regard to the resistance of the pump material. It is the responsibility of the equipment manufacturer and/or operator to ensure that all pertinent safety regulations are followed.

Specifications Model GP8265

	U.S.	(Metric)
Flow	127 GPM	(480 LPM)
Discharge Pressure	1740 PSI	(120 bar)
Power Consumption	147 BHP	106 kW
Maximum Speed.....		700 RPM
Inlet Pressure.....	29 PSI	(2.0 bar)
Plunger Diameter.....	2.55"	65 mm
Plunger Stroke	2.83"	72 mm
Crankshaft Diameter.....	2.76"	70 mm
Key Width	0.55"	14 mm
Crankshaft Mounting.....		Either side
Shaft Rotation		Top of pulley towards manifold
Temperature of Pumped Fluids.....	Up to 86° F	(30° C)*
Inlet Ports.....		(2) 3" BSP
Discharge Ports		(2) 1-1/4" BSP
Weight.....	749 lbs.	(340 kg)
Crankcase Oil Capacity	3.3 Gal.	(12.5 liters)
Valve Casing Material		Nickel plated Spheroidal Cast Iron
NPSHR	26.2 ft.-head	8.0 mWs

*higher water temperatures possible with separate crankcase cooling system; contact Giant.

Consult the factory for special requirements that must be met if the pump is to operate beyond one or more of the limits specified above.

GP8265 HORSEPOWER REQUIREMENTS					
RPM	GPM	500 PSI	750 PSI	1000 PSI	1740 PSI
350	63.5	21.9	32.9	43.8	76.2
400	72.6	25.0	37.6	50.1	87.1
500	90.7	31.3	46.9	62.6	108.8
580	105.2	32.3	54.4	72.6	126.2
700	127.0	43.8	65.7	87.6	152.4

SPECIAL NOTE:
The theoretical gallons per revolution (gal/rev) is 0.181. To find specific outputs at various RPM, use the formula:
$$\text{GPM} = 0.181 \times \text{RPM}$$

HORSEPOWER RATINGS:

The rating shown are the power requirements for the pump. Gas engine power outputs must be approximately twice the pump power requirements shown above.

We recommend a 1.15 service factor be specified when selecting an electric motor as the power source. To compute specific pump horsepower requirements, use the following formula:

$$\frac{\text{GPM} \times \text{PSI}}{1450} = \text{HP}$$

Exploded View - GP8265

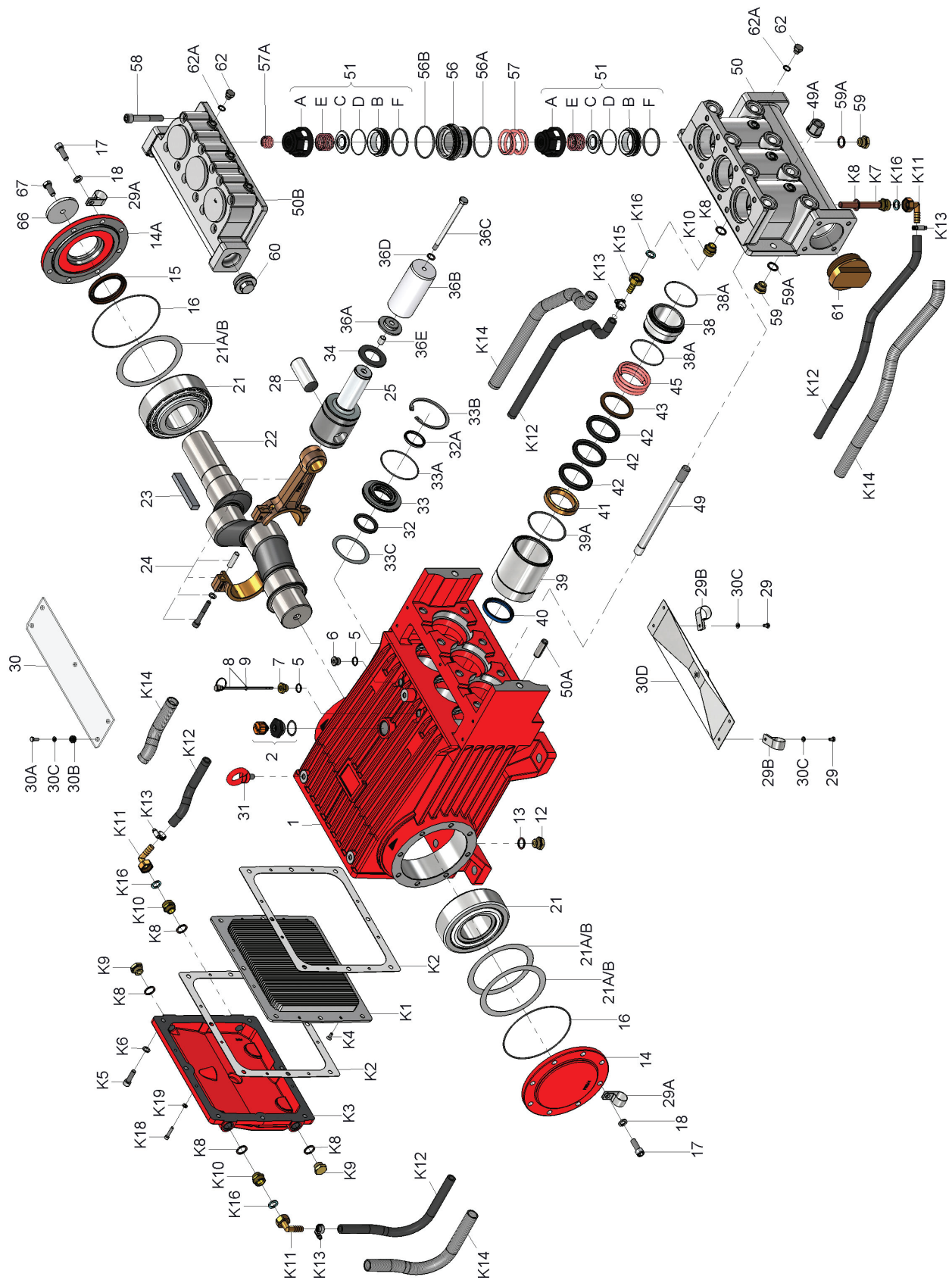

Spare Parts List - GP8265

<u>Item</u>	<u>Part</u>	<u>Description</u>	<u>Qty</u>	<u>Item</u>	<u>Part</u>	<u>Description</u>	<u>Qty</u>
1	05380	Crankcase	1	43	05118	Sleeve Support Ring	3
2	06893	Oil Filler Plug Assy with Vent	1	45	05119	Seal Tension Spring	3
5	22929	Copper Washer	2	49	05072	Stud Bolt	8
6	12256	Plug, 3/8" BSP	1	49A	05073	Hexagon Nut	8
7	05656	Plug for oil dipstick	1	50	03570	Valve Casing	1
8	05035	Oil Dipstick Assembly	1	50A	13162	Centering Stud	2
9	01009	O-Ring	1	50B	03571	Discharge Valve Casing	1
12	07109	Plug 1/2" BSP	2	51	03572	Valve Assembly	6
13	06272	Seal	2	51A	03573	Spring Tension Cap	6
14	05036	Bearing Cover Closed	1	51B	03574	Valve Seat	6
14A	05298	Bearing Cover Open	1	51C	03575	Valve Plate	6
15	05112	Radial Shaft Seal	1	51D	06560	O-Ring	6
16	05037	O-Ring	2	51E	05080	Valve Spring	6
17	05038	Hexagon Socket Screw	16	51F	03434	O-Ring	6
18	05039	Spring Ring	16	56	03576	Discharge Valve Adaptor	3
21	05044	Tapered Roller Bearing	2	56A	04955	O-Ring	3
21A	05042	Fitting Disc	1-5	56B	13156	O-Ring	3
21B	05043	Fitting Disc	1-5	57	05086	Pressure Spring	3
22	05299	Crankshaft	1	57A	07210-0100	Pressure Spring	3
23	05300	Fitting Key	1	58	05087	Hexagon Socket Screw	12
24	05047	Conneciting Rod Assembly	3	59	07109	Plug 1/2" BSP	2
25	05048	Crosshead c/w Plunger	3	59A	06272	Copper Seal	2
28	05049	Crosshead Pin	3	60	13322	Plug 1-1/2" BSP	1
29	05051	Hexagon Screw	5	61	05088	Plug 3" BSP	1
29A	05381	Bracket 1 for Cooling Hose	2	62	05302	Plug 1/4" BSP	6
29B	05383	Bracket 2 for Cooling Hose	2	62A	06934	Copper Gasket	6
30	05052	Cover Plate	1	66	05303	Disc for Crankshaft	1
30A	07225-0100	Hexagon Screw	5	67	13433	Hexagon Screw	1
30B	13136	Grommet	5	78	05025-0300	Oil Cooler Assembly	1
30C	08280	Washer	10	K1	05026	Cooling Vane Plate	1
30D	05050	Splash Cover	1	K2	05027	Seal for Gear Cover	2
31	07623	Eye Bolt	3	K3	05028-0300	Gear Cover	1
32	05058	Radial Shaft Seal	3	K4	05029	Hexagon Head Countersunk Screw	8
32A	03118	Scraper	3				
33	03119	Seal Retainer	3	K5	07381	Hexagon Socket Screw	6
33A	05056	O-Ring	3	K6	08041	Washer	6
33B	05054	Clip Ring	3	K7	05030	Connection for Oil Cooler	1
33C	05059	Fitting Disc	3	K8	06272	Copper Seal	6
34	03560	Oil Shield	3	K9	07109	Plug 1/2" BSP	2
36A	05063	Cover for Plunger Pipe	3	K10	05031	Connecting Branch	3
36B	05115	Plunger Pipe	3	K11	05032	Hose Adaptor	3
36C	05062	Tension Screw	3	K12	05033	Tube for Cooler	2
36D	07665	Copper Washer	3	K13	05402	Hose Clamp	4
36E	06900	Centering Sleeve	3	K14	05403	Hose Guard	2
38	03618	Seal Case	3	K15	05404	Hose Coupling Nut	1
38A	06667	O-Ring	6	K16	05405	Flat Gasket	4
39	05116	Seal Sleeve	3	K18	04158	Hexagon Socket Screw	4
39A	05066	O-Ring	3	K19	05053	Washer	4
40	06996	Seal Ring	3		05605	Gear End Assembly	
41	05117	Pressure Ring	3			(1-34,49,49A,50,66,67)	
42	06997	V Sleeve	9		05209	Plunger Replacement Kit	

GP8265 PUMP REPAIR KITS

Plunger Packing Kit - #09586

<u>Item</u>	<u>Part #</u>	<u>Description</u>	<u>Qty.</u>
38A	06667	O-Ring	6
39A	05066	O-Ring	3
40	06996	Seal Ring	3
42	06997	V-Sleeve	9

Oil Seal Kit - #09584A

<u>Item</u>	<u>Part #</u>	<u>Description</u>	<u>Qty.</u>
32	05058	Radial Shaft Seal	3
32A	03118	Scraper	3
33A	05056	O-Ring	3

Valve Repair Kit - #09865

<u>Item</u>	<u>Part #</u>	<u>Description</u>	<u>Qty.</u>
51	03572	Valve Assembly	6
56A	04955	O-Ring	3
56B	13156	O-Ring	3

GP8265 TOOL LIST AND TORQUE SPECIFICATIONS				
ITEM	PART #	DESCRIPTION	TORQUE AMOUNT	TOOL NEEDED
17	05038	Hexagon Socket Screw	64 ft.-lbs. (87 Nm)	10 mm Allen Wrench
24	05047	Connecting Rod Hexagon Socket	37 ft.-lbs. (50 Nm)	8 mm Allen Wrench
33B	05054	Clip Ring		Industrial Snap Ring Pliers
36C	05062	Tension Screw	30 ft.-lbs. (40 Nm)	19 mm Socket
49A	05073	Hexagon Nut (Manifold)	266 ft.-lbs. (360 Nm)	30 mm Socket
51	03572	Valve Assembly		Valve Puller (p/n 07662) included with pump
58	05087	Hexagon Socket Screw	133 ft.-lbs. (180 Nm)	12 mm Allen Wrench
K5	07381	Hexagon Socket Screw		8 mm Allen Wrench

GP8000 Troubleshooting		
Problem	Cause	Solution
Pressure drops, water leaks	V-sleeves leak	Replace V-sleeves, examine surface of plunger
Pressure drops, pump becomes loud	Discharge or suction valve leaks	Replace valve
	Steam formation (cavitation)	Reduce suction height, reduce flow resistance in inlet line, clean inlet filter, lower water temperature
Irregular pressure	Worn valves	Examine valves
	O-Ring on the valves or inlet valve adapter leaks	Examine O-ring, examine valve casing for unevenness on the sealing surfaces
Oil leaks at visible part of plunger	Gear sealing is leaky	Examine seals and running surface of plunger
Dirty mile-colored frothy oil	Oil has mixed with water	Replace oil immediately, find and fix the cause
Oil leakage on the crankshaft	Shaft seal ring leaks	Check seal and shaft
Noise increases without loss of pressure	Worn bearing	Dismantle gear, examine all parts, replace worn parts, check oil level. If service life was too short, check for excess strain or whether lubrication intervals were too long. Only specified lubricants are to be used

GP8265 PUMP REPAIR INSTRUCTIONS

7. Maintenance and Servicing

Based on the thread type and the required tightening torques, observe the table on page 6.

7.1 Special tools required

The following special tools are required for assembly:
- Assembling tool (code no. 15.0038)

7.2 Suction and Discharge Valves

Loosen screws (58), lift discharge valve casing (50B) up and away.

Take out pressure springs (57).

Pull out the complete valves (51) together with the pressure valve holder (56) using an assembly tool (order no. 07662).

To dismantle valves:

The spring tension cap (51A) is screwed together with the valve seat (51B).

Screw off spring tension cap, take out springs (51E) and valve plate (51C).

Check sealing surfaces and O-rings (51D, 51F).

Replace worn parts.

Before re-fitting the valves, clean the sealing surfaces in the casing and check for any damage.

Tighten screws (58) to the required torque.

Check torque tension after 8-10 operating hours.

8.3 Seals and Plunger

Screw off hexagon nuts (49A) and hose coupling (K11 and K15), remove pump head together with seal case (38) from crankcase (1).

If necessary, carefully tap the valve casing (50) past the centring stud (50A) using a rubber hammer.



If necessary, support the pump head by resting it on wooden blocks or by using a pulley.

Remove tension screw (36C) and take seal sleeve (39) together with all mounted parts out of the drive. Pull plunger pipe out of seal assembly and check for any damage.

Pull out spiral rings (42), guide rings (41) and support rings (40) and check for any damage.



Be careful not to damage seal sleeve (39) and guide ring (41).

Check the inner diameter of the guide ring for wear and if necessary replace together with spiral ring (42) and support ring (40). Clean all parts.

New parts should be lightly coated with silicon grease before installation.

Insert the seal unit (40, 41, 42, 43) into the sleeve. Push the ceramic plunger carefully through the seals from the crankcase side. If necessary, the seals can be held tightly using a suitable pipe support held on the other side of the seal sleeve.

Take out the seal case (38) from the valve casing (50) and check O-rings (38A) (if necessary secure 2 screwdrivers in the front O-ring groove to extract seal casing from valve casing).

Coat seals with silicon grease before installing.



Mounting surfaces of the crankcase and valve casing must be clean and free of damage.

The components must lie exactly and evenly on one another.

The same exactness applies for all centring positions in the crankcase, intermediate casing, pressure- and valve casing.

They must stand vertically on each other.

Coat the seal sleeve lightly with anti-corrosive grease (e.g. molycode no. Cu-7439) in its fitted area towards the crankcase.

Insert seal sleeves into their crankcase fittings.

Coat the threads of the tension screw (36C) lightly with thread glue and insert it together with a new copper ring (36D) through the ceramic pipe.

Turn the pump by hand until the plunger (25) rests against the plunger pipe.

Tighten tension screw to the required torque.



Thread glue must never come between the plunger pipe (36B) and centring sleeve (36E).

Overtensioning of the plunger pipe by excessive tightening of the tension screw and/or dirt or damage on the mounting surfaces can lead to plunger pipe breakage.

Insert the seal tension spring (45) and O-rings (38A, 39A) in to the seal sleeve (39).

Mounting Valve Casing:

Put seal cases (38) in the centring holes of the valve casing, then push valve casing carefully onto centring studs (50A).

Tighten hexagon nuts evenly and crosswise to the required torque.



The torque tension on the screws (49A) must be checked after 8-10 operating hours; the pump must be at zero pressure.

Thereafter the tension is to be checked every 200 operating hours.

If required, supplementary assembly instructions can be requested from the manufacturer Giant Industries.

GP8265 DIMENSIONS - (mm)

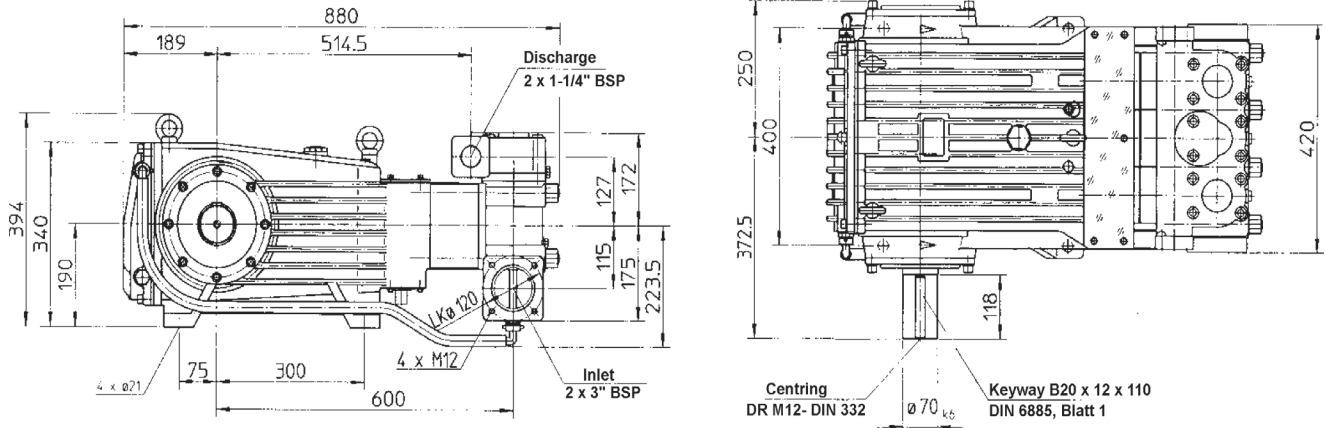

GIANT INDUSTRIES LIMITED WARRANTY

Giant Industries, Inc. pumps and accessories are warranted by the manufacturer to be free from defects in workmanship and material as follows:

1. Five (5) years from the date of shipment for all pumps used in portable pressure washers with NON-SALINE, clean water applications.
2. Two (2) years from the date of shipment for Giant pumps used in car wash applications.
3. One (1) year from the date of shipment for all other Giant industrial and consumer pumps.
4. Six (6) months from the date of shipment for all rebuilt pumps
5. Ninety (90) days from the date of shipment for all Giant accessories.

This warranty is limited to repair or replacement of pumps and accessories of which the manufacturer's evaluation shows were defective at the time of shipment by the manufacturer. The following items are NOT covered or will void the warranty:

1. Defects caused by negligence or fault of the buyer or third party.
2. Normal wear and tear to standard wear parts.
3. Use of repair parts other than those manufactured or authorized by Giant.
4. Improper use of the product as a component part.
5. Changes or modifications made by the customer or third party.
6. The operation of pumps and or accessories exceeding the specifications set forth in the Operations Manuals provided by Giant Industries, Inc.

Liability under this warranty is on all non-wear parts and limited to the replacement or repair of those products returned freight prepaid to Giant Industries which are deemed to be defective due to workmanship or failure of material. A Returned Goods Authorization (R.G.A.) number and completed warranty evaluation form is required prior to the return to Giant Industries of all products under warranty consideration. Call (419)-531-4600 or fax (419)-531-6836 to obtain an R.G.A. number.

Repair or replacement of defective products as provided is the sole and exclusive remedy provided hereunder and the MANUFACTURER SHALL NOT BE LIABLE FOR FURTHER LOSS, DAMAGES, OR EXPENSES, INCLUDING INCIDENTAL AND CONSEQUENTIAL DAMAGES DIRECTLY OR INDIRECTLY ARISING FROM THE SALE OR USE OF THIS PRODUCT.

THE LIMITED WARRANTY SET FORTH HEREIN IS IN LIEU OF ALL OTHER WARRANTIES OR REPRESENTATION, EXPRESS OR IMPLIED, INCLUDING WITHOUT LIMITATION ANY WARRANTIES OR MERCHANTABILITY OR FITNESS FOR A PARTICULAR PURPOSE AND ALL SUCH WARRANTIES ARE HEREBY DISCLAIMED AND EXCLUDED BY THE MANUFACTURER.



WARNING: This product might contain a chemical known to the State of California to cause cancer, and birth defects or other reproductive harm.
For more information go to www.P65Warnings.ca.gov

GIANT
Performance Under Pressure

GIANT INDUSTRIES, INC.

900 N. Westwood Ave.
Toledo, Ohio 43607
(419) 531-4600
FAX (419) 531-6836
www.giantpumps.com
© Copyright 2023 Giant Industries, Inc.