

Performance data for intermittent operation, data for continuous operation on request.
 For information on intermittent operation and calculating of the performance data, see the Giant assembly instructions.

NPSHR / Inlet pressure
 Required NPSH refers to water (at 68 °F or 20 °C) at maximum permissible pump speed.
 Maximum inlet pressure: 29 PSI (2.0 bar).

Level of noise emission
 Emission sound pressure level ≤93 dB(A)

2. Fields of application

The fields of application of these pump types correspond to the specifications in the assembly instructions of Giant pumps.

3. Ambient conditions

Ambient temperature: $41^{\circ}\text{F} (5^{\circ}\text{C}) < T_{\text{Amb.}} < 86^{\circ}\text{F} (30^{\circ}\text{C})$

4. Oil Filling

- Filling quantity: 1.9 gallons (7.2 L)
- Quality: Industrial gear oil **ISO VG 220** or automotive gear oil **SAE 90 GL4** or **Giant's equivalent (p/n 01154)**
- Intervals: first oil change after **50 operating hours** than every **500 operating hours**, but at the latest after **12 months**

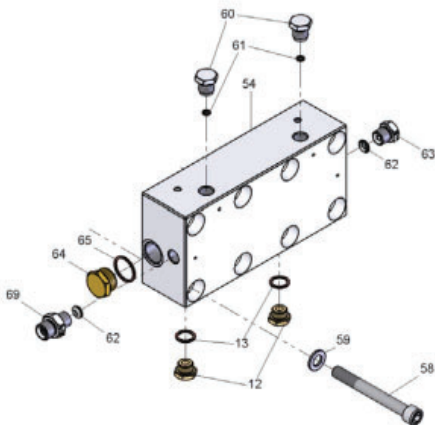

5. Installation/Putting into Operation

5.1 Shaft protector

When the pump is in operation, the open shaft end must be covered up by shaft protector (21), the driven shaft side and coupling by a contact-protector.

To cover the exposed crankshaft end, mount the shaft guard (21) together with the holder (21A) onto the bearing cover (14) and secure with bearing cover screws (17).

5.2 Direction of pump rotation

Set the direction of rotation of the drive unit according to the direction of rotation arrow on the crankcase.

5.3 Suction line filter

Recommended mesh size 50 µm.

6. Operation

Maximum operation pressure is attainable at 600 - 800 rpm. If the speed is reduced further, the pump pressure must be reduced in the same proportion to ensure sufficient gearbox lubrication.

6.1 Discharge Line

The pump comes with two special lens seals (62) which have to be inserted in to the discharge ports of the pump. One of the two ports is to be closed with the included plug (63).

The 1/2" BSP high-pressure hose connection for the discharge line must be constructed as per the below drawing to ensure that together with lens seal (62) the discharge line is completely sealed.

We offer the high-pressure connection (05361) with UNF 9/16" female threads for high-pressure fittings.

The two 1/2" BSP connections on the top side of the valve casing are closed off with plug (60) and copper seal ring (61). These two connections are for the optional fitting of a pressure gauge and/or safety valve such as our 23140.

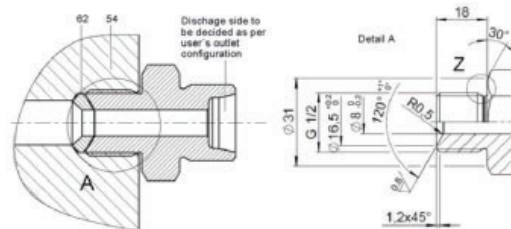

Should a pressure gauge or safety valve be installed, the copper ring (61) must remain in the bore.

Pressure gauges with a 1/2" BSP connection have the appropriate contour so that the copper ring sits properly.

The alignment of the pressure gauge cannot be determined exactly after tightening.

We offer the double nipple (05362) for mounting the 23140 pressure relief valve.

For further information, see assembly instructions of Giant Pumps