

INTRODUCING

P518

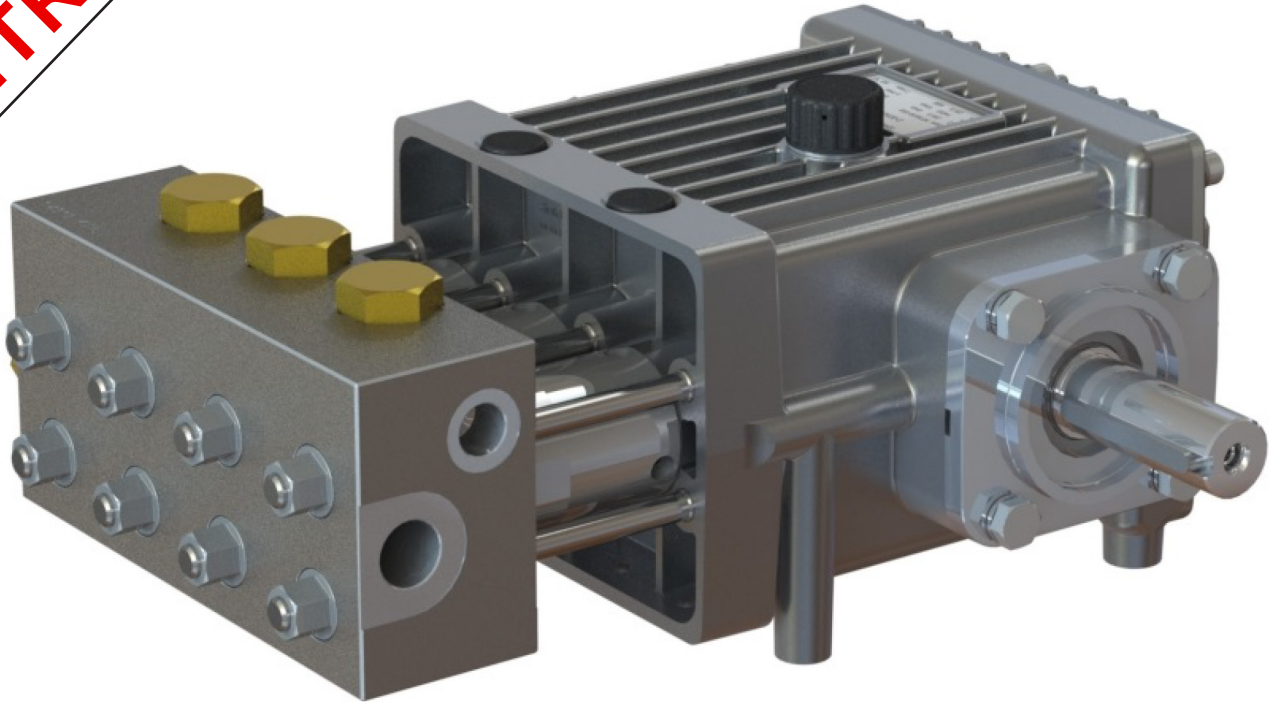

Applications

- Contract Cleaning
- Hydrostatic Testing
- Surface Preparation
- Deburring
- Painting Contractors
- Central Cleaning Stations

Specifications*

	U.S.	Metric
Volume.....	7.4 GPM.....	28 L/min
Pressure	7250 PSI.....	500 bar
Speed		1450 RPM
Power	38.3 HP.....	28.6 kW
Temperature	104 °F.....	40 °C
Plunger Size	0.71".....	18 mm
Plunger Stroke.....	1.10".....	28 mm
Weight	73.8 lbs.....	33.5 kg

*Intermittent duty

GIANT

Performance Under Pressure

GIANT INDUSTRIES, INC.

900 N. Westwood Ave.

Toledo, Ohio 43607

(419) 531-4600

FAX (419) 531-6836

www.giantpumps.com

© Copyright 2022 Giant Industries, Inc.

Construction

- Crankcase: Aluminum
- Crankshaft: Drop forged, hardened, ground and polished
- Bearings: Tapered Roller
- Connecting Rods: Bronze
- Plungers: Hard Metal Coating
- Seals: Nitrile with fabric reinforcing with weep return system
- Valves: High Grade Stainless Steel
- Manifold: Stainless Steel

Dimensions - Inches (mm)

