

Models MP4126-5100 & MP4130-5100

Triplex Ceramic Plunger Pump
Operating Instructions/
Repair and Service Manual

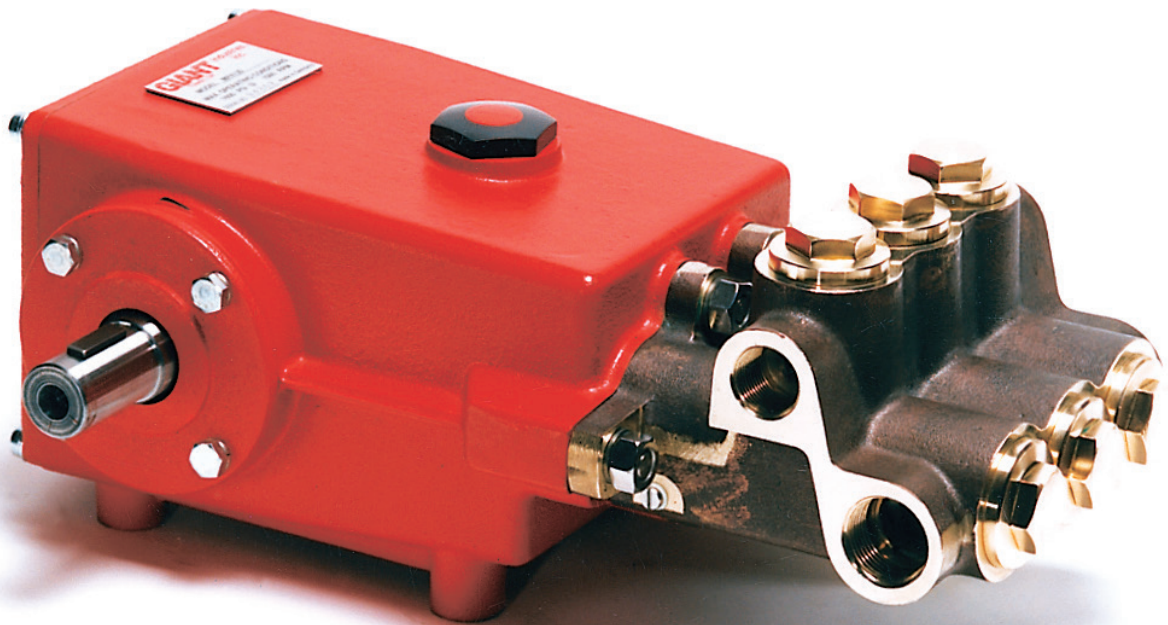

GIANT
Performance Under Pressure

Contents:

Installation Instructions:	page 2
Preventive Maintenance and Recommended Spare Parts List:	page 2
Pump Specifications:	page 3
Exploded View:	page 4
Parts List:	page 5
Repair Kits:	page 5
Torque Specifications:	page 5
Repair Instructions:	page 6
Dimensions:	page 7
Warranty Information:	back page

INSTALLATION INSTRUCTIONS

Required NPSH refers to water: Specific weight 1kg/dm³, viscosity 1 °E at max. permissible revolutions.

Operation and Maintenance

Check oil level prior to starting and ensure trouble-free water supply.

Oil: Use 33.8 fl. ounces (1.0 liters) of Giant's part number 01154 or ISO VG 220 GL4 (e.g. Aral Degol BG220) or SAE 90 GL4 gear oil.

Initial change after 50 operating hours and then every 1000 hours, after 1 year operation in any case.

Caution: When operating in damp places or with high temperature fluctuations. Oil must be changed immediately, should condensate (frothy oil) occur in the gear box.

Keep NPSH under control.

Max. input pressure 145 PSI (10 bar), max. suction head -4.35 (-0.3 bar).

Safety Rules

Pump operation without safety valve as well as any excess in the temperature or speed limits automatically voids the warranty. The safety valve must be regulated in accordance with the guidelines for liquid spraying units so that the admissible operating pressure can not be exceeded by more than 10%.

When the pump is in operation, the open shaft end must be covered up by shaft protector (21), the driven shaft side and coupling by a contact protector.

Pressure in discharge line and in pump must be at zero before any maintenance to the pump takes place. Close up suction line. Disconnect fuses to ensure that the driving motor does not get switched on accidentally.

Make sure that all parts on the pressure side of the unit are vented and refilled, with pressure at zero, before starting the pump.

In order to prevent air, or an air/water-mixture being absorbed and to prevent cavitation occurring, the pump-NPSHR, positive suction head and water temperature must be kept under control.

Cavitation and/or compression of gases lead to uncontrollable pressure kicks which can ruin pump and unit parts and also be dangerous to the operator or anyone standing nearby.

Giant plunger pumps are suitable for pumping clean water and other non-aggressive or abrasive media with a specific weight similar to water.

Before pumping other liquids - especially inflammable, explosive and toxic media - the pump manufacturer must under all circumstances be consulted with regard to the resistance of the pump material. It is the responsibility of the equipment manufacturer and/or operator to ensure that all pertinent safety regulations are adhered to.

Preventative Maintenance Check-List & Recommended Spare Parts List						
Check	Daily	Weekly	50hrs	Every 500 hrs	Every 1500 hrs	Every 3000 hrs
Oil Level/Quality	X					
Oil Leaks	X					
Water Leaks	X					
Belts, Pulley		X				
Plumbing		X				
Recommended Spare Parts						
Oil Change (1 Quart)			X	X		
Seal Kit (1 kit/pump) (See page 5 for kit list)					X	
Valve Spare Parts (1 kit/pump) (See page 5 for kit list)						X

MP4126-5100 & MP4130-5100 - Pump Specifications

U.S. Measurements

	Max. Flow	Max. Pressure	Max. Speed	Power Required	Max. Temperature	Plunger Diameter	NPSH Required
Model	GPM	PSI	RPM	HP	°F	in	Ft-Head
MP4130	15.4	1600*	1100	17.6	160	1.18	29.5
MP4126	17.9	1600	1100	20.4	160	1.18	N/A

*Intermittent rating of 2000 PSI

Metric Measurements

	Max. Flow	Max. Pressure	Max. Speed	Power Required	Max. Temperature	Plunger Diameter	NPSH Required
Model	L/min	bar	RPM	kW	°C	mm	mWs
MP4130	58.2	110*	1100	13.1	70	30	9
MP4126	67.7	110	1100	15.2	70	30	N/A

*Intermittent rating of 140 bar

Consult the factory for special requirements that must be met if the pump is to operate beyond one or more of the limits specified above.

Horsepower Ratings:

We recommend a 1.15 service factor be specified when selecting an electric motor as the power source.

To compute electric motor horsepower required, use the following formula: $HP = (GPM \times PSI) / 1450$.

The formula to determine the horsepower required for a gas engine is: $HP = (GPM \times PSI) / 1150$.

For the Application of a Hydraulic Motor:

To Determine the Torque of a Hydraulic Motor -- $(GPM \times PSI \times 36.77) / RPM = \text{Torque (in-lbs)}$

Calculating RPM / GPM of Pump:

A pump must be connected to an electric motor or gas or diesel engine with the correct ratio of pulleys and belts to attain the required speed and GPM. The use of a Variable Frequency Drive (VFD) may also be used to control the RPM of a properly sized electric motor when variable flows are required.

$$(\text{Max. Pump RPM} / \text{Rated Pump GPM}) \times \text{Required Pump GPM} = \text{Required Pump RPM}$$

To calculate a pulley diameter one (1) pulley diameter and the required pump RPM must be known:

$$(\text{Pump RPM} \times \text{Pump Pulley Diameter}) / \text{Motor RPM} = \text{Motor Pulley Diameter}$$

$$(\text{Motor RPM} \times \text{Motor Pulley Diameter}) / \text{Pump RPM} = \text{Pump Pulley Diameter}$$

Common Specifications:

Inlet Pressure 145 PSI (10 Bar)
 Crankshaft Diameter..... 1.10" (28 mm)
 Crankcase Oil Capacity 33.8 fl. oz. (1 L)
 Inlet Ports (2) 1" NPT
 Discharge Ports (2) 3/4" NPT
 Stroke (except MP4126)..... 1.02" (26 mm)
 Stroke (MP4126 only)..... 1.18" (30 mm)
 Weight 66 lbs (30 kg)
 Shaft Rotation..... Top of Pulley Toward Fluid End

Materials Used for MP Pumps:

Manifold AISI 316 Stainless Steel
 Plungers Solid Ceramic Oxide
 Valves High Grade Stainless Steel
 Seals..... Nitrile with Fabric Reinforcing
 Gear End Spheroidal Cast Iron

Exploded View - MP4126-5100 & MP4130-5100 Pumps

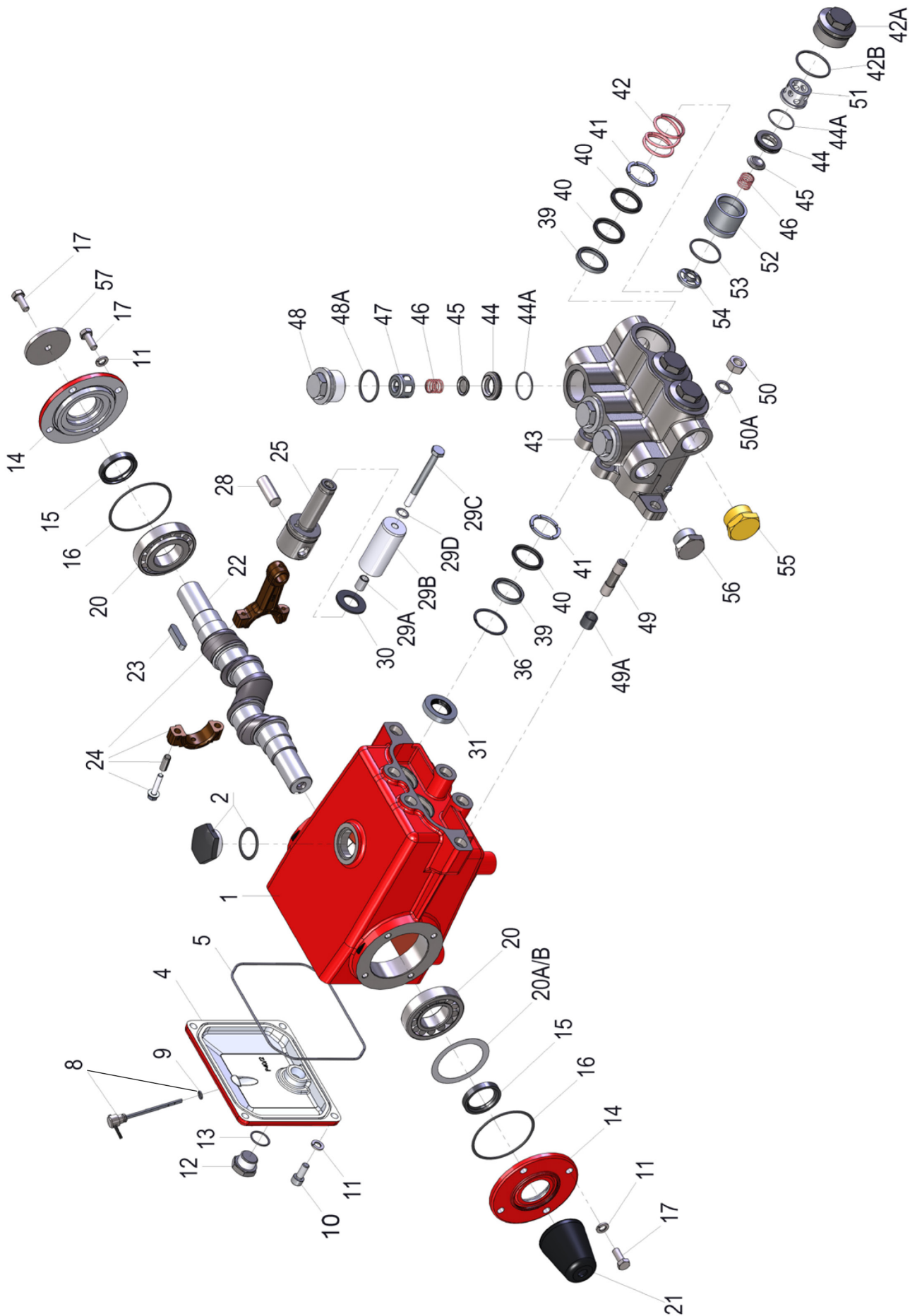

MP4126-5100 & MP4130-5100 Spare Parts List

<u>ITEM</u>	<u>PART #</u>	<u>DESCRIPTION</u>	<u>QTY.</u>	<u>ITEM</u>	<u>PART#</u>	<u>DESCRIPTION</u>	<u>QTY.</u>
1	06100	Crankcase	1	30	06136	Flinger	3
2	13000	Oil Filler Cap Assembly	1	31	07260	Crankcase Oil Seal	3
4	07243	Cover, Crankcase	1	36	07267-0100	Snap Ring	3
5	07244	O-Ring, Crankcase Cover	1	39	07271-0100	Pressure Ring	6
8	01008	Oil Dip Stick Assembly	1	40	07272	V-Sleeve	9
9	01009	O-Ring, Dip Stick	1	41	07273-0100	Support Ring	6
10	01010-0400	Screw, Crankcase Cover	4	42	07353	Tension Spring	3
11	01011-0400	Spring Washer	12	42A	06103-0100	Tension Plug	3
12	07109-0400	Oil Drain Plug	1	42B	06736	O-Ring, Tension Plug	3
13	06015	O-Ring, Oil Drain Plug	1	43	06963-5000	Manifold	1
14	07245	Bearing Cover	2	44	07280-0100	Valve Seat	6
15	07247	Seal, Crankshaft	2	44A	06003-0001	O-Ring, Valve Seat	6
16	07627	O-Ring, Bearing Cover	2	45	06791-0100	Valve Plate	6
17	07114-0100	Hex Screw, Bearing Cover	9	46	07283	Valve Spring	6
20	07248	Roller Bearing, Tapered	2	47	04153	Spring Retainer, Discharge	3
20A	07249	Fitting Disc	2	48	07356-0100	Plug, Discharge	3
20B	06962	Fitting Disc	2	48A	06965	O-Ring	3
21	05375	Shaft Protector	1	49	06109	Stud, Manifold	6
22	07251	Crankshaft (MP4130)	1	49A	07319	Shim, Stud	2
22	04149	Crankshaft (MP4126)	1	50	07158	Nut, Manifold Stud	6
23	13331	Key	1	50A	07159	Spring Washer	6
24	07253	Connecting Rod Assembly	3	51	06110-0100	Spacer	3
25	07596	Crosshead Complete	3	52	06112-0100	Valve Housing	3
28	07255	Crosshead Pin	3	53	06965	O-Ring	3
29A	07256	Centering Sleeve	3	54	04154	Spring Tension Disc	3
29B	07261	Ceramic Plunger	3	55	13321-0100	Plug, 1" BSP	1
29C	07257-0100	Tension Screw	3	56	13150-0100	Plug, 3/4" BSP	1
29D	07161-0100	Steel Ring	3	57	13020	Disc for Crankshaft	1

MP4126-5100 & MP4130-5100 Repair Kits

Plunger Packing Kit # 09042-5100

<u>Item</u>	<u>Part #</u>	<u>Description</u>	<u>Qty</u>
40	07272	V-Sleeve	6
42B	06736	O-Ring, Tension Plug	3

Valve Repair Kits # 09581

<u>Item</u>	<u>Part #</u>	<u>Description</u>	<u>Qty</u>
42B	06736	O-Ring Tension Plug	3
44	07280-0100	Valve Seat	6
44A	06003-0001	O-Ring, Valve-Seat	6
45	06791-0100	Valve Plate	6
46	07283	Valve Spring	6
47	04153	Spring Retainer	3
48A	06965	O-Ring	3
53	06965	O-Ring	3
54	04154	Spring Tension Disc	3

MP4126-5100 & MP4130-5100 TORQUE SPECIFICATIONS

<u>Position</u>	<u>Item #</u>	<u>Description</u>	<u>Lubrication Info</u>	<u>Torque Amount</u>
1	06100	Crankcase	Loctite 270	N/A
10	01010-0400	Screw, Crankcase Cover		221 in.-lbs. (25 Nm)
12	07109-0400	Oil Drain Plug		30 ft.-lbs. (40 Nm)
15	07247	Crankshaft Seal	Loctite 403	
17	07114-0100	Hex Screw, Bearing Cover		221 in.-lbs. (25 Nm)
24	07253	Hex Screw, Connecting Rod		106 in.-lbs. (12 Nm)
29C	07257-0100	Tension Screw	Loctite 243	247 in.-lbs. (28 Nm)
31	07260	Crankcase Oil Seal	Loctite 403	N/A
42A	06103-0100	Plug, Inlet		107 ft.-lbs. (145 Nm)
48	07356-0100	Plug, Discharge		107 ft.-lbs. (145 Nm)
49	06109	Stud, Manifold	Loctite 638 (crankcase side)	
50	07158	Nut, Manifold Stud		59 ft.-lbs. (80 Nm)

Repair Instruction - MP4126-5100 & MP4130-5100

To Check Valves

Suction Valves: Remove plugs (42A). Take out spacer pipe (51) and suction valve adaptor (52). Push valve parts and as necessary spacer pipe (51) out of suction valve adaptor using a soft tool.

Check and replace worn parts. Check O-rings (42B, 44A and 53). Replace as necessary.

Discharge Valves: Remove plugs (48). Remove spring tension cap (47), valve spring (46) and valve plate (45) from the discharge valve. Take out valve seat (44) with a valve puller tool.
Check and replace worn parts.

Check O-rings (44A, 48A) and replace as necessary.

Tighten plugs (42A, 48) to 107 ft.-lbs. (145 Nm).

To Check Seals and Plunger Pipe

Remove plugs (42A). Loosen nuts (50) and remove valve casing (43) from plungers by pulling away from the crankcase (1). Take out spacer pipe (51), suction valve adaptor (52), tension spring (42) and seal-unit (39-41).

Check surfaces of plunger pipes (29B) as damaged surfaces cause fast wear to the seals.

Before installing use mineral grease to help install v-sleeves (40).

Check O-rings (42B, 44A and 53) and replace as necessary.

Check rear v-sleeve (40) after having removed snap ring (36) and replace as necessary.

If plunger pipe (29B) has to be replaced, loosen tension screw (29C) and remove it together with the plunger pipe (29B). Check and clean plunger (25) surfaces and install new plunger pipe and seal washer (29D).
Cover thread of tension screw (29C) with a fine film of liquid glue and tighten carefully to 247 in.-lbs. (28 Nm).

Important! Care must be taken that no glue gets between the plunger pipe (29B) and centring sleeve (29A). The plunger pipe should not be strained by eccentric tightening of tension screw, nor through dirt or damage to the front surface of the plunger as this could cause the plunger pipe to break.

Install tension spring (42), spring tension disc (54), valve housing (52) and spacer (51) and then tighten plug (42A) to 107 ft.-lbs. (145 Nm).
Install valve casing (43) and tighten nuts (50) evenly to 59 ft.-lbs. (80 Nm).

To Dismantle Gear

After dismantling the valve casing (43) and plunger pipes (29B), drain the oil. Remove crankcase cover (4) and bearing covers (14).

Loosen connecting rod screws (24) and push stem of connecting rod halves as far as possible into the crosshead guides.

Important! Connecting rods (24) are marked for identification. Do not twist connecting rod halves. Connecting rods must be reinstalled in the same position on shaft journals.

While turning slightly, hit the crankshaft (22) to one side with a rubber hammer.

Important! Do not bend the front portion of the connecting rods. Check the crankshaft (22) and connecting rod (24) surfaces, shaft seals (15 and 31) and taper roller bearings (20).

To Reassemble

Using a soft tool, press in the outer bearing ring till the outer edge lines up with the outer edge of the bearing hole.

Remove bearing cover (14) together with shaft seal (15) and O-ring (16). Fit crankshaft (22) through bearing hole on the opposite side. Press in outer bearing (20), and tension it inwards with the bearing cover. Keep the crankshaft in vertical position and turn it slowly so that the taper rollers of the bearings touch the edge of the outer bearing ring.

Adjust axial bearing clearance to at least 0.1mm and maximum 0.15mm by placing fitting discs (20A/20B) under the bearing cover (14).

Important! After assembly has been completed, the crankshaft should turn easily with very little clearance.

Tighten connecting rod screws (24) to 106 in.-lbs. (12 Nm).

MP4126-5100 & MP4130-5100 Dimensions - Inches (mm)

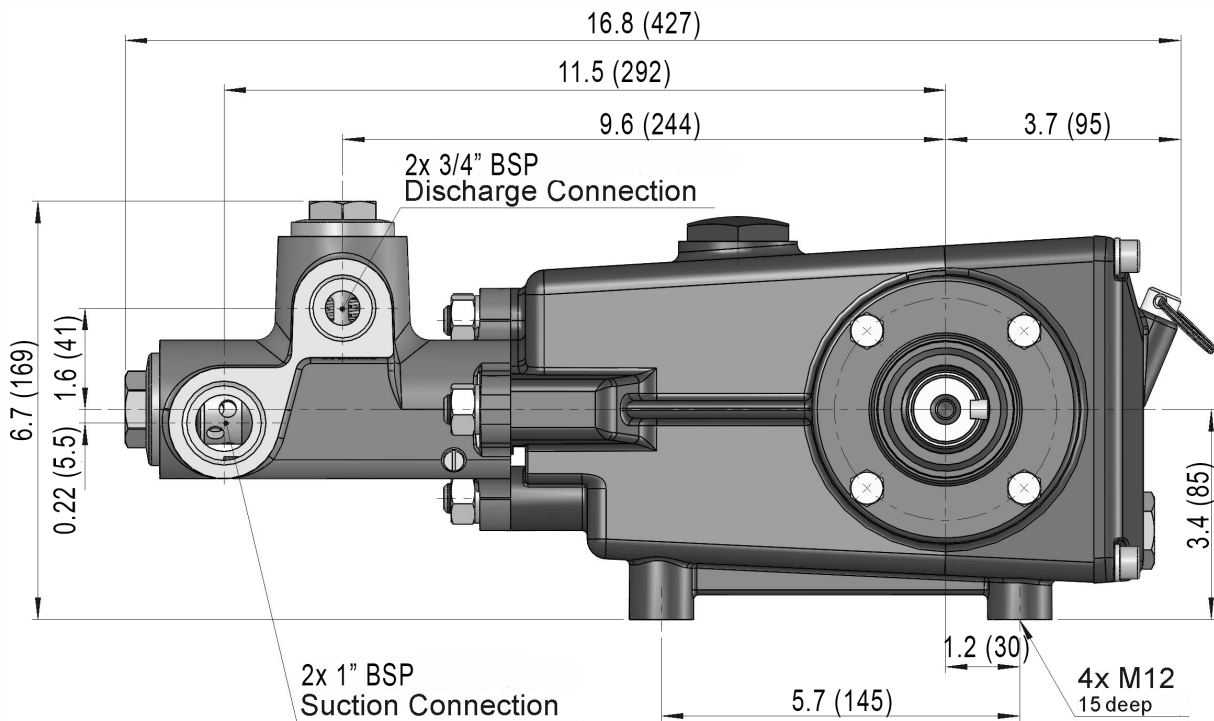
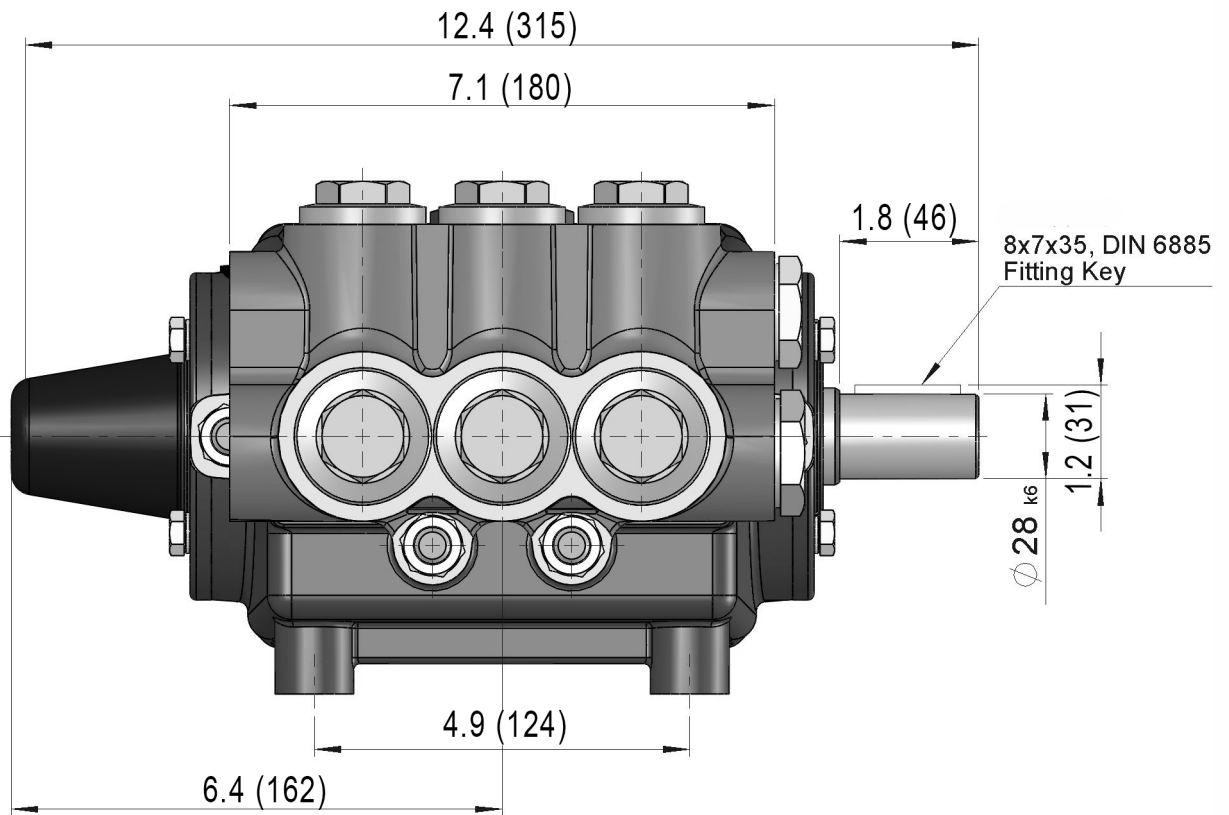

GIANT INDUSTRIES LIMITED WARRANTY

Giant Industries, Inc. pumps and accessories are warranted by the manufacturer to be free from defects in workmanship and material as follows:

1. Five (5) years from the date of shipment for all pumps used in portable pressure washers with NON-SALINE, clean water applications.
2. Two (2) years from the date of shipment for Giant pumps used in car wash applications.
3. One (1) year from the date of shipment for all other Giant industrial and consumer pumps.
4. Six (6) months from the date of shipment for all rebuilt pumps
5. Ninety (90) days from the date of shipment for all Giant accessories.

This warranty is limited to repair or replacement of pumps and accessories of which the manufacturer's evaluation shows were defective at the time of shipment by the manufacturer. The following items are NOT covered or will void the warranty:

1. Defects caused by negligence or fault of the buyer or third party.
2. Normal wear and tear to standard wear parts.
3. Use of repair parts other than those manufactured or authorized by Giant.
4. Improper use of the product as a component part.
5. Changes or modifications made by the customer or third party.
6. The operation of pumps and or accessories exceeding the specifications set forth in the Operations Manuals provided by Giant Industries, Inc.

Liability under this warranty is on all non-wear parts and limited to the replacement or repair of those products returned freight prepaid to Giant Industries which are deemed to be defective due to workmanship or failure of material. A Returned Goods Authorization (R.G.A.) number and completed warranty evaluation form is required prior to the return to Giant Industries of all products under warranty consideration. Call (419)-531-4600 or fax (419)-531-6836 to obtain an R.G.A. number.

Repair or replacement of defective products as provided is the sole and exclusive remedy provided hereunder and the MANUFACTURER SHALL NOT BE LIABLE FOR FURTHER LOSS, DAMAGES, OR EXPENSES, INCLUDING INCIDENTAL AND CONSEQUENTIAL DAMAGES DIRECTLY OR INDIRECTLY ARISING FROM THE SALE OR USE OF THIS PRODUCT.

THE LIMITED WARRANTY SET FORTH HEREIN IS IN LIEU OF ALL OTHER WARRANTIES OR REPRESENTATION, EXPRESS OR IMPLIED, INCLUDING WITHOUT LIMITATION ANY WARRANTIES OR MERCHANTABILITY OR FITNESS FOR A PARTICULAR PURPOSE AND ALL SUCH WARRANTIES ARE HEREBY DISCLAIMED AND EXCLUDED BY THE MANUFACTURER.



WARNING: This product might contain a chemical known to the State of California to cause cancer, and birth defects or other reproductive harm.

For more information go to www.P65Warnings.ca.gov

GIANT

Performance Under Pressure

GIANT INDUSTRIES, INC.

900 N. Westwood Ave.

Toledo, Ohio 43607

PHONE (419) 531-4600

FAX (419) 531-6836

www.giantpumps.com

© Copyright 2022 Giant Industries, Inc.

02/22 MP4126_MP4130-5100.indd