

Model GP5132GBHS

Triplex Ceramic
Plunger Pump
Operating Instructions /
Manual

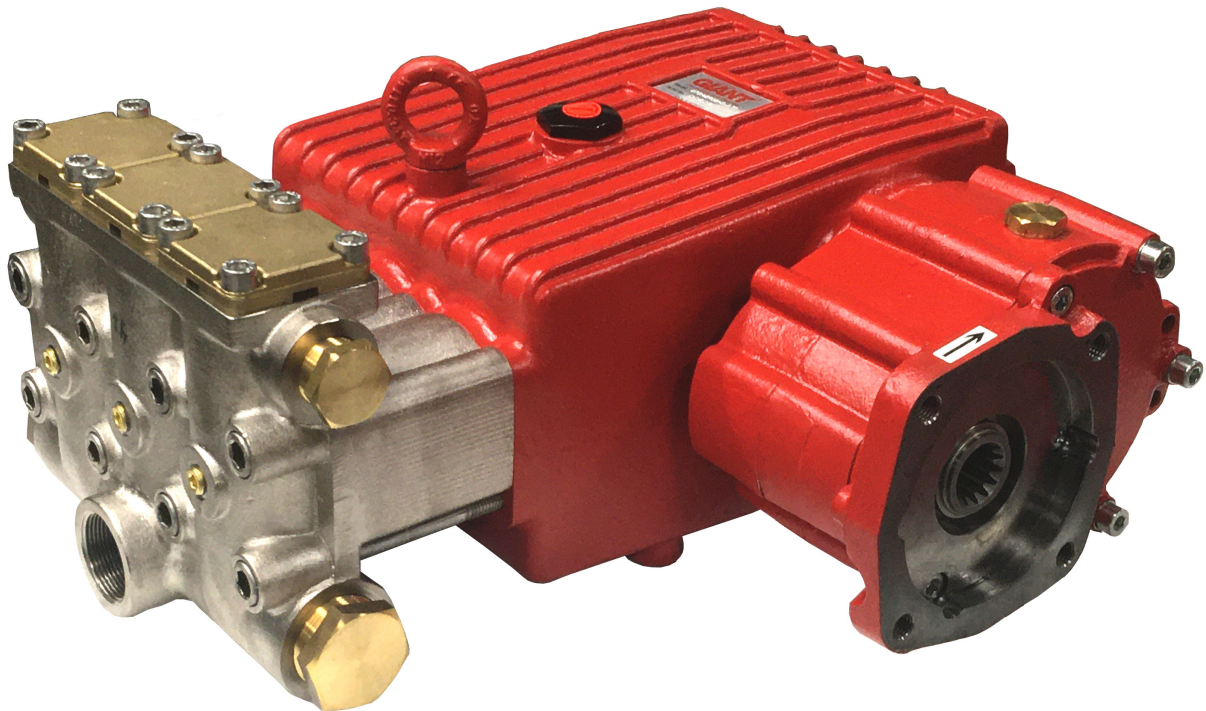

GIANT
Performance Under Pressure

Updated 10/24

Contents:	
Installation Instructions:	page 2
Pump Specifications:	page 3
Exploded View:	page 4
Parts List:	page 5
Kits/Torque Specs:	page 6
Repair Instructions:	page 7
Dimensions:	back page
Warranty Information	back page

INSTALLATION INSTRUCTIONS

Figures for speed (rpm) and pressure apply to interval operation with cold water. For continual operation, the speed of all pump models must be limited to 700 rpm and the maximum operating pressure reduced by 10%.

Required NPSH refers to water: Specific weight 1kg/dm³, viscosity 1°E at maximum permissible revolutions.

Operation and Maintenance

Check oil level prior to starting and ensure trouble-free water supply. **Oil:** Use only 1.3 gallons (5.0 liters) of Industrial Gear Lube Oil (Giant p/n 01154) or ISO VG 220 (e.g. Aral Degol BG220) or SAE 90 gear oil.

Initial change after 50 operating hours and then every 500 operating hours.

Caution: When operating in damp places or with high temperature fluctuations or when condensate (frothy oil) occurs in the gear box, the oil should immediately be changed.

Keep NPSH under control.

Maximum input pressure 145 PSI (10 bar), maximum suction head -4.35 PSI (-0.3 bar).



Safety Rules

Pump operation without safety valve as well as any excess in temperature or speed limits automatically voids the warranty. The safety valve must be regulated in accordance with the guidelines for liquid spraying units so that the admissible operating pressure can not be exceeded by more than 10%.

Before any maintenance to the pump takes place, pressure in discharge line and in pump must be at zero. Close up suction line. Disconnect fuses to ensure that the driving motor does not get switched on accidentally.

Before starting the pump, make sure that all parts on the pressure side of the unit are vented and refilled and the pressure is at zero.

In order to prevent air, or an air/water-mixture being absorbed and to prevent cavitation occurring, the pump-npshr, positive suction head and water temperature must be kept under control.

Cavitation and/or compression of gases lead to uncontrollable pressure-kicks which can ruin pump and unit parts and also be dangerous to the operator or anyone standing nearby.

Giant plunger pumps are suitable for pumping clean water and other non-aggressive or abrasive media with a specific weight similar to water.

Before pumping other liquids - especially inflammable, explosive and toxic media - the pump manufacturer must under all circumstances be consulted with regard to the resistance of the pump material. It is the responsibility of the equipment manufacturer and/or operator to ensure that all pertinent safety regulations are adhered to.

Specifications

Model GP5132GBHS

	U.S.	Metric
Maximum Volume (Continuous)	27.7 GPM	104.9 LPM
Maximum Volume (Intermittent).....	40.0 GPM.....	151.0 LPM
Maximum Discharge Pressure	3000 PSI	200 bar
Power Required.....	57.4 BHP	42.8 kW
Crankshaft Speed.....		1000 RPM
Maximum Inlet Pressure.....	-4.35 to 145 PSI	-0.3 to 10 bar
Plunger Diameter.....	1.26"	32 mm
Crankshft Stroke.....	1.81"	46 mm
Crankshaft Bore.....		SAE-C Spline 14T 12/24DP
Crankshaft Mounting		Either side
Shaft Rotation.....		Hydraulic Gear towards back of pump
Temperature of Pumped Fluids	Up to 140 °F	60 °C
Inlet Ports		(3) 1-1/2" NPT
Discharge Ports		(2) 1" NPT
Weight	269 lbs.	122 kg
Crankcase Oil Capacity	1.3 Gal.	5.0 liters
Fluid End Material.....		Nickel-Plated Spheroidal Cast Iron

Consult the factory for special requirements that must be met if the pump is to operate beyond one or more of the limits specified above.

GP5132GBHS Horsepower Requirements					
RPM	GPM	1000 PSI	1500 PSI	2000 PSI	3000 PSI
500	13.9	9.6	14.7	19.2	28.8
600	16.6	11.5	17.2	22.9	34.4
700	19.4	13.4	20.1	26.8	40.1
800	22.2	15.3	23.0	30.6	45.9
900	24.9	17.2	25.8	34.4	51.5
1000	27.7	19.1	28.7	38.2	57.3

EXPLODED VIEW - GP5132GBHS

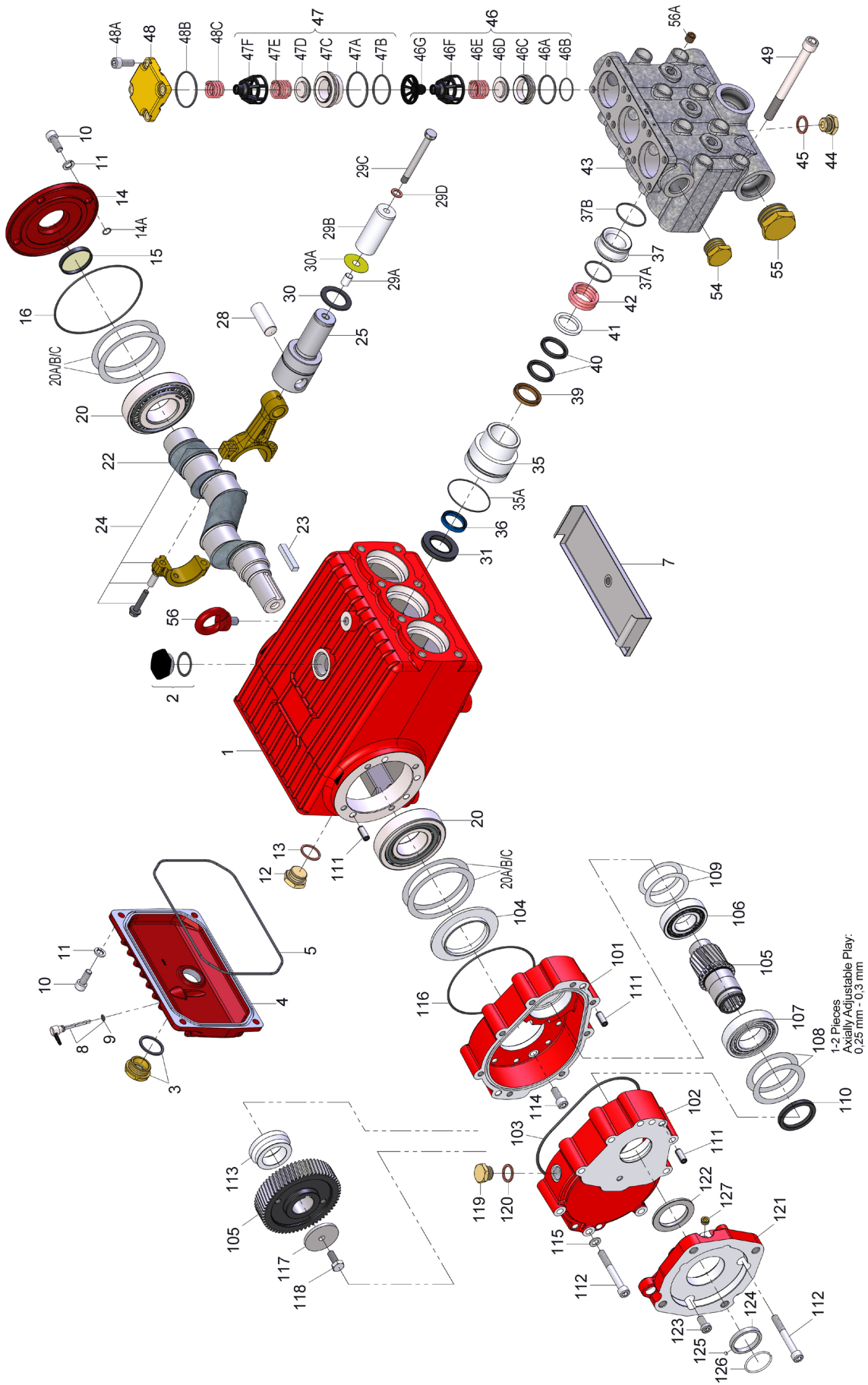

1-2 Pieces
Axially Adjustable Play:
0,25 mm - 0,3 mm

GP5132GBHS SPARE PARTS LIST

<u>ITEM</u>	<u>PART</u>	<u>DESCRIPTION</u>	<u>QTY.</u>	<u>ITEM</u>	<u>PART</u>	<u>DESCRIPTION</u>	<u>QTY.</u>
1	03248	Crankcase	1	46D	13306	Valve Plate	3
2	13000	Oil Filler Plug Assembly	1	46E	13307	Valve Spring	3
3	05943	Oil Sight Glass Assembly	1	46F	13308	Spring Tension Cap	3
4	13267	Crankcase Cover	1	46G	13309	Spacer Pipe	3
5	13268	O-Ring	1	47	13311	Discharge Valve Assembly	3
7	04334	Drip Pan	1	47A	13289	O-Ring	3
8	07105	Oil Dip Stick Assembly	1	47B	07700	O-Ring	3
9	01009	O-Ring, Dip Stick	1	47C	13314	Discharge Valve Seat	3
10	07008	Inner Hexagon Screw	8	47D	13306	Valve Plate	3
11	06725	Spring Washer	8	47E	13307	Valve Spring	3
12	07703	Drain Plug, 3/4" BSP	1	47F	13308	Spring Tension Cap	3
13	07704	Gasket, Drain Plug	1	48	13316	Plug	3
14	03249	Bearing Cover	1	48A	07008	Inner Hexagon Screw	12
14A	03250	O-Ring	4	48B	07740	O-Ring	3
15	08439	Lid	1	48C	07232	Pressure Spring	3
16	08380	O-Ring	1	49	13339	Inner Hexagon Screw	8
20	13206	Taper Roller Bearing	2	54	06626	Plug, 1" NPT	1
20A	13207	Shim, 0.1mm	1-5	55	06627	Plug, 1-1/2" NPT	2
20B	04723	Shim, 0.15mm	1-5	56	07623	Eye Bolt	1
20C	04724	Shim, 0.2mm	1-5	56A	22610	Plug, 1/4" NPT	3
22	03251	Crankshaft	1	101	03257	Bottom Casing for Gear	1
23	03252	Fitting Key	1	102	03195	Top Casing for Gear	1
24	13276	Connecting Rod Assembly	3	103	03196	O-Ring	1
25	13279	Crosshead Assembly	3	104	03253	Centering Ring	1
28	13281	Crosshead Pin	3	105	03315	Gearwheel Set, 1.75:1	1
29A	07125	Centering Sleeve	3	105	03329	Gearwheel Set, 2.0:1	1
29B	13022	Plunger Pipe	3	105	03290	Gearwheel Set, 2.75:1	1
29C	13031	Tensioning Screw	3	106	03199	Cylinder Roller Bearing	1
29D	07755	Copper Ring	3	107	03200	Cylinder Roller Bearing	1
30	13282	Oil Scraper	3	108	03201	Shim, 0.1 mm	1-3
30A	05889	Washer for Drip Shield	3	109	07249	Shim, 0.1 mm	1-3
31	13284	Radial Shaft Seal	3	110	05058	Radial Shaft Seal	1
35	13359	Seal Sleeve	3	111	04744	Cylindrical Pin	4
35A	08183	O-Ring	3	112	03202	Hexagon Socket Screw	8
36	13360	Grooved Ring	3	113	03255	Spacer Ring for Gear	1
37	13361	Seal Case	3	114	07008	Hexagon Socket Screw	4
37A	07700	O-Ring	3	115	08041	Washer	8
37B	07653	O-Ring	3	116	08380	O-Ring	1
39	13026	Pressure Ring	3	117	13362	Disc for Crankshaft	1
40	13027	V-Sleeve	6	118	13358	Hexagon Screw	1
41	13028	Sleeve Support Ring	3	119	07109	Plug, 1/2" BSP	2
42	07173	Tension Spring	3	120	06272	Copper Seal Ring, 1/2"	2
43	13300	Valve Casing	1	121	03291	Flange for Gearbox	1
44	07109	Plug, 1/2" BSP	1	122	03292	Centering Ring	1
45	06272	Copper Seal Ring, 1/2"	1	123	03293	Hexagon Socket Screw	1
46	13302	Suction Valve Assembly	3	124	03294	Ring for Speed Sensor	1
46A	12055	O-Ring	3	125	03295	Magnet for Speed Sensor	1
46B	08059	O-Ring	3	126	03296	Clip Ring	1
46C	13304	Suction Valve Seat	3	127	03297	Plug	1

GP5132GBHS REPAIR KITS

Plunger Packing Kit #09290

<u>Item</u>	<u>Part#</u>	<u>Description</u>	<u>Qty.</u>
35B	08183	O-Ring	3
36	13360	Grooved Ring	3
37A	07700	O-Ring	3
37B	07653	O-Ring	3
40	13027	V-Sleeve	6

Oil Seal Kit #09230

<u>Item</u>	<u>Part #</u>	<u>Description</u>	<u>Qty.</u>
31	13284	Oil Seal	3

Valve Assembly Kits

Inlet Valve Kit #09231

<u>Item</u>	<u>Part #</u>	<u>Description</u>	<u>Qty.</u>
46A	12055	O-Ring	1
46B	08059	O-Ring	1
46C	13304	Valve Seat	1
46D	13306	Valve Plate	1
46E	13307	Valve Spring	1

Discharge Valve Kit # 09232

<u>Item</u>	<u>Part #</u>	<u>Description</u>	<u>Qty.</u>
47A	13289	O-Ring	1
47B	07700	O-Ring	1
47C	13314	Valve Seat	1
47D	13306	Valve Plate	1
47E	13307	Valve Spring	1

Complete Valve Repair Kit #09812

<u>Item</u>	<u>Part #</u>	<u>Description</u>	<u>Qty.</u>
46A	12055	O-Ring	3
46B	08059	O-Ring	3
46C	13304	Inlet Valve Seat	3
46D	13306	Valve Plate	3
46E	13307	Valve Spring	3
46F	13308	Spring Tension Cap	3
46G	13309	Spacer Pipe	3
47A	13289	O-Ring	3
47B	07700	O-Ring	3
47C	13314	Discharge Valve Seat	3
47D	13306	Valve Plate	3
47E	13307	Valve Spring	3
47F	13308	Spring Tension Cap	3
48B	07740	O-Ring	3

GP5132GBHS Pump				
Torque Specifications and Lubrication Information				
Position	Item #	Description	Lubrication	Torque Amount
1	03248	Crankcase	Molycote Cu-Paste	
3	05943	Oil Sight Glass Assembly	Loctite 572	22 ft.-lbs (30 Nm)
10	07008	Inner Hexagon Screw		33 ft.-lbs. (45 Nm)
12	07703	Drain Plug, 3/4" BSP		74 ft.-lbs. (100 Nm)
24	13276	Connecting Rod Assembly		22 ft.-lbs. (30 Nm)
29C	13031	Tension Screw, Plunger	Loctite 243	22 ft.-lbs. (30 Nm)
31	13284	Radial Shaft Seal	Loctite 403	
48A	07008	Inner Hexagon Screw, Plug		35 ft.-lbs. (47 Nm)
49	13339	Inner Hexagon Screw, Valve Casing		89 ft.-lbs. (120 Nm)

GP5132GBHS Repair Instructions

To Check Valves

Remove inner hexagon screw (48A) and remove plugs (48) with a screwdriver. Check O-rings on plugs (48B). Pull out tension spring (48C). Remove the spring tension disc (47F) from discharge valve lying underneath by screwing in the M10-screw. Take out spring (47E) and plate (47D). Pull out valve seat (47C) by means of a valve puller. Check sealing areas of plate and valve seat for damage and replace worn parts. Check O-rings (47A) and (47B). Screw spacer pipe (46G) out of spring tension cap (46F) in the suction valve lying underneath. Remove suction valve by screwing in an M10-screw. Check O-ring (46A) and (46B). If valve seat (46C) remains in the valve casing (43) then carry forth as described for discharge valve. When reassembling, use new O-rings if possible and oil them before installing. Tighten inner hexagon screws (48A) to 35 ft.-lbs. (47 Nm).

To Check Seals and Plunger Pipe

Loosen the inner hexagon screws (49) and pull off valve casing (43) to the front. Pull seal sleeves (35) out of guides in crankcase and over the plunger pipe (29B). Pull support ring (41), sleeves (40) and pressure ring (39) out of seal sleeve. Check plunger surfaces, sleeves (40) and grooved rings (36). Replace worn parts. If the plunger pipe is worn out, loosen tension screw (29C) and pull off plunger pipe to the front. Clean contact surfaces of plunger (25) thoroughly. Then place new plunger pipe carefully through the oiled seals into the seal case. Check o-rings on seal sleeves and seal case and replace worn o-rings. Then push seal sleeve together with plunger pipe into the crankcase guide. Turn gear carefully until plunger (25) comes up against the plunger pipe. Put a new copper gasket (29D) onto the tension screw (29C). Cover the thread of tension screw and the gasket with glue and tighten to 29 ft.-lbs. (30 Nm).

Important! Care must be taken that no glue gets between the plunger pipe (29B) and the centering sleeve (29A). The plunger pipe should not be strained by eccentric tightening of the tension screw or through damage to front of surface of plunger, otherwise it will probably break. Tighten the inner screws (49) for the valve casing evenly to 89 ft.-lbs. (120 Nm).

To Dismantle Gear

As described above, remove valve casing (43) and plunger pipe (29B), drain the oil. Remove the gear cover (4) and bearing cover (14). Loosen connecting rod screws (24A) and push the front of the connecting rod (24) forward as far as possible into the crosshead guide.

IMPORTANT! Connecting rods (24) are marked for identification. Do not twist connecting rod halves. Connecting rod is to be reinstalled in the same position on shaft journals.

IMPORTANT! Do not bend the connecting rod (24) shanks. Check crankshaft (22) and connecting rod (24) surfaces, radial shaft seals (15) and taper roller bearings (20).

To remove the oil seals (31) use a wooden rod and sharply hit down on the oil seals from the crankcase (1). Note: when replacing the oil seals, apply a small amount of locktight to the outside edges of each oil seal before reinserting them into the crankcase.

To Dismantle Reduction Gear

Remove screws (69). Remove top casing (59); it may be necessary to use a rubber mallet. Remove screw (76) and disc (75). Pull gear wheel (62) off of the shaft. Remove screws (71), bottom casing (58) and centering ring (61). Turning the crankshaft (22) slightly, hit it out carefully to the side with a rubber hammer.

To Reassemble

Using a soft tool, press in the outer bearing ring until the outer edge lines up with the outer edge of the bearing hole. Remove bearing cover (14) together with radial shaft seal (15) and o-ring (16). Fit crankshaft (22) through bearing hole on the opposite side. Press in outer bearing and tighten it inwards with the bearing cover, keeping the crankshaft in vertical position and turning slowly so that the taper rollers of the bearings touch the edge of the outer bearing ring. Adjust axial bearing clearance to at least 0.1mm and maximum 0.15mm by placing fitting discs (20A, 20B and 20C) under the bearing cover.

IMPORTANT! After assembly has been completed, the crankshaft should turn easily with very little clearance. Tighten connecting rod screws (24A) to 22 ft.-lbs. (30 Nm). Reassemble the fluid end (see instructions above). If cylinder roller bearing (65) was removed, heat them up (before pressing onto the pinion shaft). Slightly press the gearwheel (62) onto the crankshaft (22) so that remaining portion of the gearwheel set can be positioned in the correct manner. Carefully, tap the gearwheel and the pinion (simultaneously) onto the crankshaft and into the bearing seat. Reassemble remaining gearbox parts making sure not to damage the radial shaft seal (67) or the o-ring (60).

IMPORTANT! Before putting the pump into operation, turn the reduction gear (by hand) at least four times in each direction (to ensure proper alignment). Reassemble shaft cover (14) and crankcase cover (4) and properly torque screws (17 & 10).

IMPORTANT! The 1/2" BSP connection in the crankcase serves the purpose of draining leakage water. The connection should not be closed (see the drawing to the right).

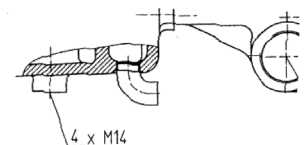

DIMENSIONS - INCHES (MM)

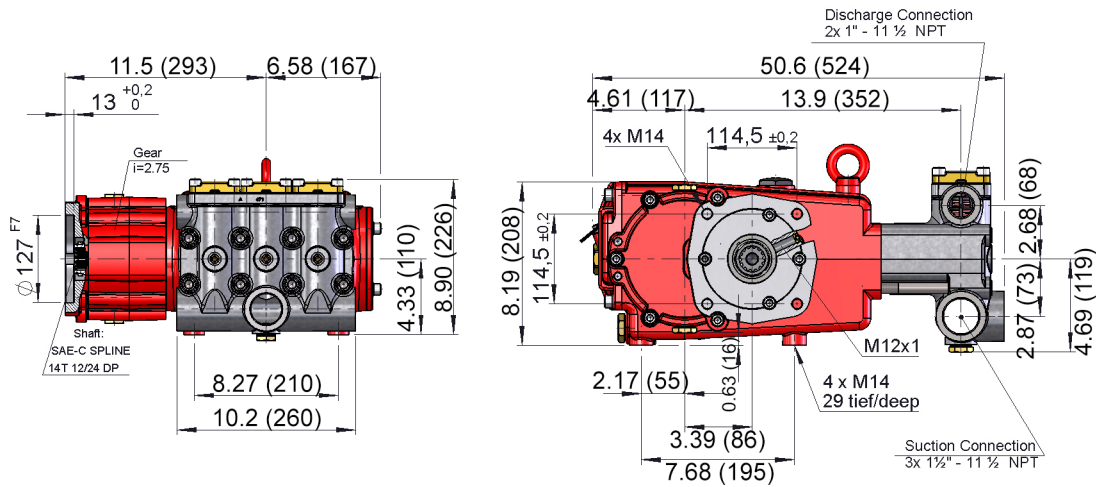

GIANT INDUSTRIES LIMITED WARRANTY

Giant Industries, Inc. pumps and accessories are warranted by the manufacturer to be free from defects in workmanship and material as follows:

1. Five (5) years from the date of shipment for all pumps used in portable pressure washers with NON-SALINE, clean water applications.
2. Two (2) years from the date of shipment for Giant pumps used in car wash applications.
3. One (1) year from the date of shipment for all other Giant industrial and consumer pumps.
4. Six (6) months from the date of shipment for all rebuilt pumps
5. Ninety (90) days from the date of shipment for all Giant accessories.

This warranty is limited to repair or replacement of pumps and accessories of which the manufacturer's evaluation shows were defective at the time of shipment by the manufacturer. The following items are NOT covered or will void the warranty:

1. Defects caused by negligence or fault of the buyer or third party.
2. Normal wear and tear to standard wear parts.
3. Use of repair parts other than those manufactured or authorized by Giant.
4. Improper use of the product as a component part.
5. Changes or modifications made by the customer or third party.
6. The operation of pumps and or accessories exceeding the specifications set forth in the Operations Manuals provided by Giant Industries, Inc.

Liability under this warranty is on all non-wear parts and limited to the replacement or repair of those products returned freight prepaid to Giant Industries which are deemed to be defective due to workmanship or failure of material. A Returned Goods Authorization (R.G.A.) number and completed warranty evaluation form is required prior to the return to Giant Industries of all products under warranty consideration. Call (419)-531-4600 or fax (419)-531-6836 to obtain an R.G.A. number.

Repair or replacement of defective products as provided is the sole and exclusive remedy provided hereunder and the MANUFACTURER SHALL NOT BE LIABLE FOR FURTHER LOSS, DAMAGES, OR EXPENSES, INCLUDING INCIDENTAL AND CONSEQUENTIAL DAMAGES DIRECTLY OR INDIRECTLY ARISING FROM THE SALE OR USE OF THIS PRODUCT.

THE LIMITED WARRANTY SET FORTH HEREIN IS IN LIEU OF ALL OTHER WARRANTIES OR REPRESENTATION, EXPRESS OR IMPLIED, INCLUDING WITHOUT LIMITATION ANY WARRANTIES OR MERCHANTABILITY OR FITNESS FOR A PARTICULAR PURPOSE AND ALL SUCH WARRANTIES ARE HEREBY DISCLAIMED AND EXCLUDED BY THE MANUFACTURER.



WARNING: This product might contain a chemical known to the State of California to cause cancer, and birth defects or other reproductive harm.

For more information go to www.P65Warnings.ca.gov