

Model LP121-5100HT(C)

Triplex Ceramic
Plunger Pump
Operating Instructions/
Repair and Service
Manual

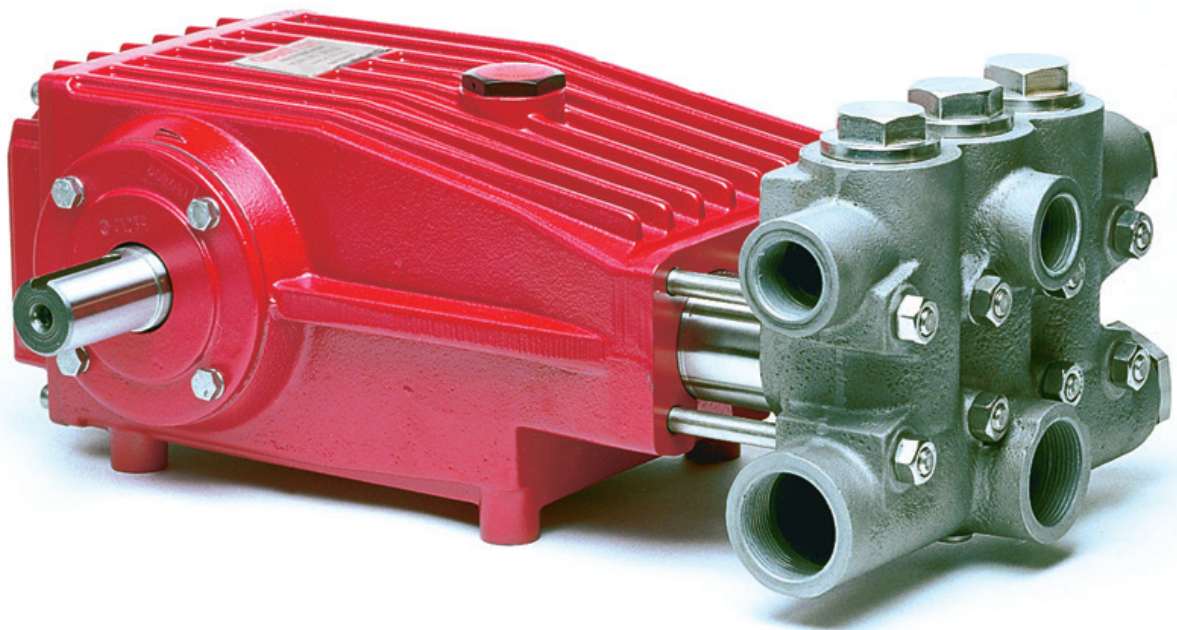

LP121-5100HT Shown

GIANT
Performance Under Pressure

Contents:

Installation Instructions:	page 2-3
Exploded View:	page 4
Parts List / Kits:	page 5
Pump Specifications:	page 6
Repair Instructions:	page 7
Torque Specifications:	page 7
Dimensions:	back page
Warranty Information:	back page

Updated 04/21

INSTALLATION INSTRUCTIONS

Required NPSH refers to water: Specific weight 1kg/dm³ at 570 RPM.

 Before putting the pump into operation, please read operating instructions carefully!

IMPORTANT! When renewing the high pressure plunger seal (pos. 40), do not use grease. Hot water causes grease to wash off the seal which in turn can jam the valves!

Before installation, the new seals should only be oiled lightly.

Operation and Maintenance

Check oil level prior to starting and ensure trouble-free water supply.

IMPORTANT! If there is a **danger of frost**, the water in the pump and in the pump fittings (particularly the unloader valve) must be emptied. The second discharge port can also be used and the pump run “dry” for 1-2 minutes for this purpose.

Oil amount: 101 ounces (3.0 litres). Only use **ISO VG 220 industrial gear oil** (e.g. Aral Degol BG220) or **automobile gear oil SAE 90 GL4 (Giant's p/n 01154)**.

Initial change after 50 operating hours and then every 1000 operating hours, or after 1 year if used less.

Caution: When operating in damp places, with high temperature fluctuations or if condensate (frothy oil) occurs in the gear box, oil must be changed immediately.

Keep NPSH under control.

Maximum input pressure 145 PSI (10 bar), maximum suction head -4.35 PSI (-0.3 bar). Make sure that suction pulsation is sufficiently dampened – water column resonance must be avoided.

Safety Rules

Pump operation without safety valve as well as any excess in temperature or speed limits automatically voids the warranty. The safety valve must be regulated in accordance with the guidelines for liquid spraying units so that

the admissible operating pressure can not be exceeded by more than 10%.

When the pump is in operation, the open shaft end must be covered up by shaft protector (21); the driven shaft side and coupler must be covered by a belt guard or bell housing.

To cover the exposed crankshaft end, mount the shaft guard (21) together with the holder (21A) onto the bearing cover (14) and secure with bearing cover screws (17).

Before any maintenance to the pump takes place pressure in discharge line and in pump must be at zero. Close up suction line. To ensure that the driving motor does not get switched on accidentally, disconnect fuses.

Before starting the pump, make sure that all parts on the pressure side of the unit are vented and refilled and that the the pressure is set at zero.

In order to prevent air, or an air/water-mixture being absorbed and to prevent cavitation occurring, the pump-npshr, positive suction head and water temperature must be kept under control.

Cavitation and/or compression of gases lead to uncontrollable pressure-kicks which can ruin pump and unit parts and also be dangerous to the operator or anyone standing nearby.

Giant Plunger Pumps are suitable for pumping clean water and other non-aggressive or abrasive media with a specific weight similar to water.

Before pumping other liquids - especially inflammable, explosive and toxic media - the manufacturer must under all circumstances be consulted with regard to the resistance of the pump material. It is the responsibility of the manufacture and/or operator to ensure that all pertinent safety regulations are adhered to.

INSTALLATION INSTRUCTIONS

Supplementary Information

Giant Triplex Pump LP121HT(C) has been especially constructed for pumping hot water e.g. steam boiler storage. The plunger seals (40) on the water side are made out of a high temperature-resistant material. Rinsing chambers behind the high pressure seals through which cold water can flow thus increasing the life of the seals are available upon request LP121HT(C). The cold water connections (59) are suited to the Ermeto-pipe 6mm diameter. The operator can also use hose nipples; there are 1/8" BSP threads in the seal sleeve for this purpose.

The cold water 68 °F - 104 °F (20 °C - 40 °C) can be guided into the pump from either side and flows out on the opposite side e.g. into a drain. The cold water flow rate should be at least 17 ounces/min (0.5 L/min) and must be put into use as soon as the pump is started.

If the cold water doesn't start flowing immediately the pump is put into operation, the ceramic plunger (29B), could crack under the cold shock.

IMPORTANT! The cooling water must be delimited to avoid lime formation due to warming.

IMPORTANT! If the location of the pump doesn't allow for cooling, on no account are the connections in the seal sleeves (35) to be closed up because this is where water from the high pressure seals has to drip out.

The pipe bends (58) should be removed in this case. To ensure the seals are properly greased, the openings in the screw-in joints (57) should be used to fill the rinsing chambers with high-temperature-resistant grease by means of a grease gun.

In the case of water temperature above 194 °F (90 °C), we strongly recommend the cold-water rinse.

Plant Lay-Out

For perfect functioning of the pump, the following points must be adhered to.

a) Pressure in Suction Side

The stipulated NPSHR is the minimum required pressure above the vapor pressure of the medium and is never to fall short of this figure. Temperature and vapor pressure of the medium, the geodetical height of the location, the flow rate and loss of friction in the suction line, must all be taken into consideration. It may be necessary to install a booster pump (centrifugal pump) in the suction line.

b) Pulsation

Due to its construction, the plunger pump creates pulsation in the suction and discharge lines. Suction pulsation in particular must be dampened in order to prevent resonance in the suction line which in turn, causes cavitation. Therefore, the pump is never to be connected by a rigid pipe but rather by a flexible hose (not reinforced by steel), and if possible 1.5 to 2 times wider than the suction connection. If a booster pump is used, the hose is to be attached between the booster pump and the high pressure pump.

If several pumps are used, each pump must have its own suction line. If this can't be done, a suction air chamber or a suction flow stabilizer must be installed in front of each pump. The bladder in the stabilizer is to be pretensioned on location.

Depending on the layout of the plant, a pressure accumulator may be necessary on the discharge side. This pressure accumulator must be installed right behind the discharge outlet of the high pressure pump. We recommend the use of only one pressure accumulator in the discharge line in order to avoid irritation which could be caused by different pretension levels in the accumulators.

Gas-tension in both the suction flow stabilizer and in the pressure accumulator are to be checked regularly.

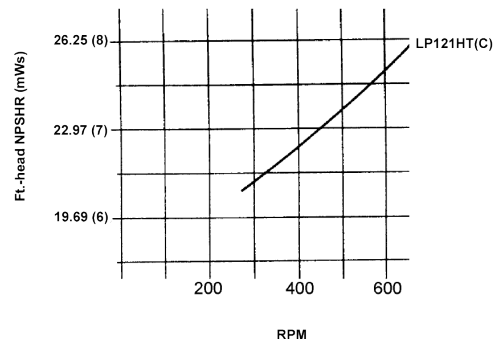

EXPLODED VIEW - LP121-5100HT(C) PUMP

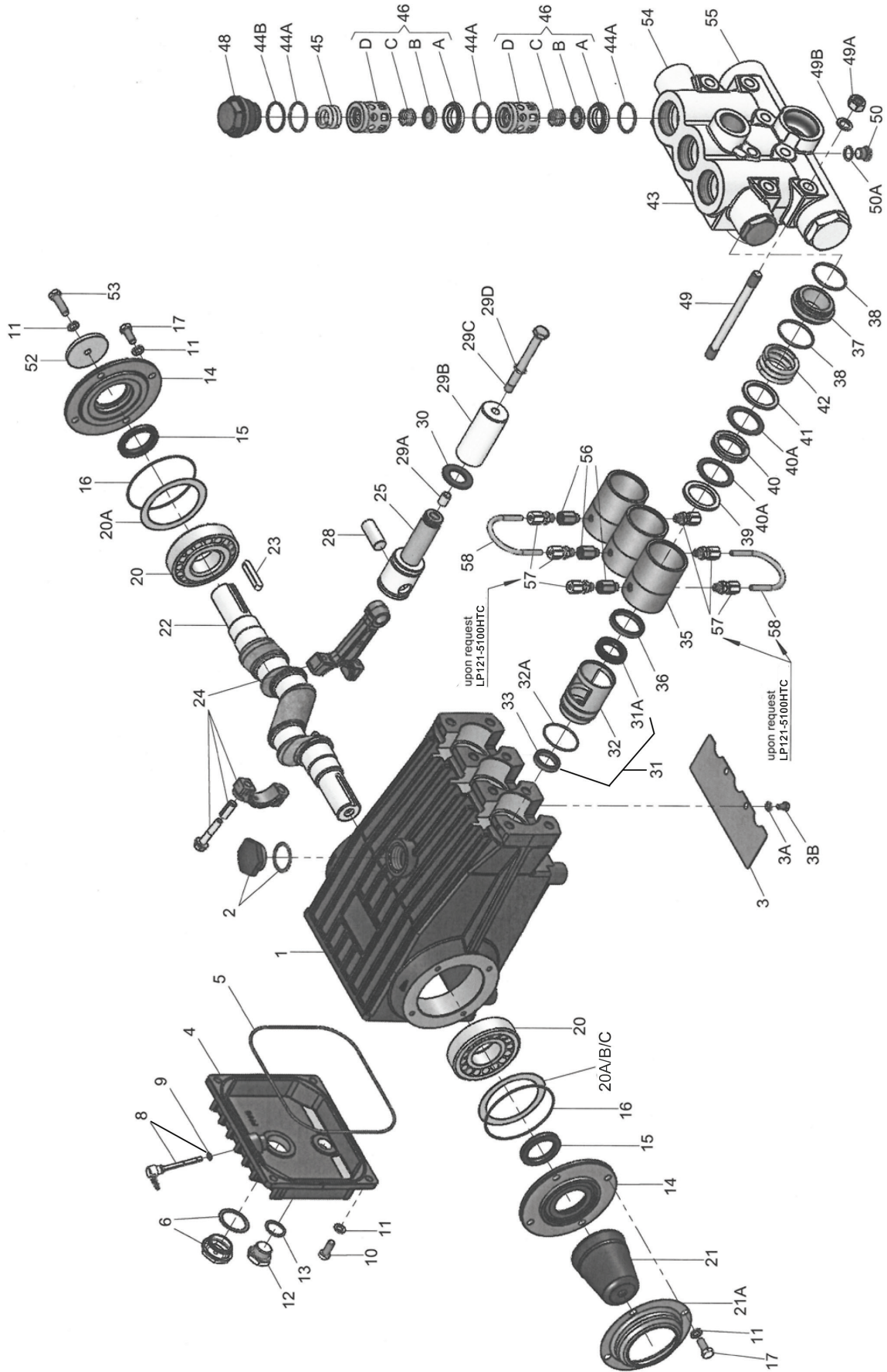

PARTS LIST - LP121-5100HT(C) PUMPS

Item	Part	Description	Qty.	Item	Part	Description	Qty.
1	05198	Crankcase	1	31A	06118	Oil Seal	3
2	13000	Oil Filler Plug Assembly	1	32	06116	Oil Seal Retainer	3
3	05940	Cover Plate	1	32A	05596	O-Ring	3
3A	07223-0100	Spring Washer	2	33	06117	Compact Ring	3
3B	05051-0100	Hexagon Screw	2	35	03343	Seal Sleeve	3
4	06085	Crankcase Cover	1	36	07137	Leakage Seal	3
5	07104	O-Ring	1	37	07139-0100	Seal Case	3
6	07186	Oil Sight Glass Assembly	1	38	07140	O-Ring	6
8	06086	Oil Dipstick Assembly	1	39	03344	Pressure Ring	3
9	01009	O-Ring	1	40	06917	Spring Ring	3
10	01010-0100	Hexagon Socket Screw	4	40A	06916	Support Ring	6
11	01011-0400	Spring Washer	13	41	03345	Support Ring	3
12	07109-0400	Oil Drain Plug	1	42	07147	Tension Spring	3
13	06015	O-Ring	1	43	13018-5000	Valve Casing	1
14	07111	Bearing Cover	2	44A	07150	O-Ring	9
15	07112	Crankshaft Seal	2	44B	06266	Support Ring	3
16	07113	O-Ring	2	45	06078	Spring	3
17	07114-0100	Hexagon Screw	8	46	07060-0100	Valve Assembly (46A-D)	6
20	07116	Taper Roller Bearing	2	46A	07064-0100	Valve Seat	6
20A	07117	Shim, 0.1 mm	1-3	46B	07063-0100	Valve Plate	6
20B	13001	Shim, 0.15 mm	1-3	46C	07062-0100	Valve Spring	6
20C	04091	Shim, 0.2 mm	1-3	46D	07066	Spring Retainer	6
21	05376	Shaft Protector	1	48	06077-0100	Plug	3
21A	05377	Shaft Guard Holder	1	49	07157	Stud Bolt	8
22	03367	Crankshaft	1	49A	07158	Nut	8
23	08091	Key	1	49B	07159	Washer	8
24	13340	Connecting Rod Assembly	3	50	07423-0100	Plug, 1/4" BSP	1
25	13341	Crosshead Plunger	3	50A	07755-0100	Steel Ring, 1/4" BSP	1
		Base Assembly	3	52	13020	Disc for Crankshaft	1
28	13232	Crosshead Pin	3	53	04561	Hexagon Screw	1
29A	07125	Sleeve	3	54	13044	Plug, 1" BSP	2
29B	07130	Plunger Pipe	3	55	13322-0100	Plug, 1-1/2" BSP	2
29C	07131-0100	Plunger Bolt	3	56	03311	Threaded Pipe, LP121HTC	3
29D	07161A-0100	Steel Ring	3	57	06588	Push-In Fitting, LP121HTC	6
30	07779	Flinger	3	58	06587	Elbow	2
31	06120	Seal Retainer, Complete (31A-33)	3				

LP121-4000HT(C) PUMP REPAIR KITS

Plunger Packing Kit #09844

Item	Part No.	Description	Qty
36	07137	Leakage Seal	3
38	07140	O-Ring	6
39	03344	Pressure Ring	3
40	06917	Spiral Ring	3

Valve Assembly Kit #09196-0100

Item	Part No.	Description	Qty
44A	07150	O-Ring	9
44B	06266	Support Ring	3
46A	07064-0100	Valve Seat	6
46B	07063-0100	Valve Plate	6
46C	07062-0100	Valve Spring	6

Oil Seal Kit #09571

Item	Part No.	Description	Qty
31A	06118	Oil Seal	3
32A	05596	O-Ring	3
33	06117	Compact Ring	3

Specifications

LP121-5100HT(C) Pumps

	U.S.	Metric
Volume.....	17.7 GPM / 1059 GPH.....	66.8 L/min / 4010 L/hr
Discharge Pressure.....	1160 PSI.....	80 bar
Inlet Pressure.....	-4.35 to 145 PSI.....	-0.3 to 10 bar
Power Consumption.....	14.1 BHP.....	10.5 kW
Maximum Crankshaft Speed.....		570 RPM
Plunger Diameter.....	1.42".....	36 mm
Stroke.....	1.57".....	40 mm
Crankcase Oil Capacity.....	101 ounces.....	3.0 L
Temperature of Pumped Fluids.....	220 °F.....	105 °C
Inlet Ports.....		(3) 1-1/4" BSP
Discharge Ports.....		(3) 1" BSP
Crankshaft Mounting.....		Either Side
Shaft Rotation.....	Top of Pulley Towards Fluid End	
Weight.....	120.6 lbs.....	54.7 kg
Crankshaft Diameter.....		35 mm
NPSHR.....	25.3 Ft. of head.....	7.7 m. of head

PULLEY INFORMATION

Pulley selection and pump speed are based on a 1725 RPM motor and "B" section belts. When selecting desired GPM, allow for a ±5% tolerance on pumps output due to variations in pulleys, belts and motors among manufacturers.

1. Select GPM required, then select appropriate motor and pump pulley from the same line.
2. The desired pressure is achieved by selecting the correct nozzle size that corresponds with the pump GPM.

HORSEPOWER INFORMATION

Horsepower ratings shown are the power requirements for the pump. Gas engine power outputs must be approximately twice the pump power requirements shown above.

We recommend that a 1.1 service factor be specified when selecting an electric motor as the power source. To compute specific pump horsepower requirements, use the following formula:

$$(GPM \times PSI) / 1450 = HP$$

LP121-5100HT(C) Horsepower Requirements					
RPM	GPM	300 PSI	600 PSI	900 PSI	1160 PSI
200	6.2	1.3	2.6	3.8	5.0
300	9.3	1.9	3.8	5.8	7.4
400	12.4	2.6	5.1	7.7	9.9
500	15.5	3.2	6.4	9.6	12.4
570	17.6	3.7	7.3	11.0	14.1

REPAIR INSTRUCTION - LP121-5100HT(C) PUMPS

To Check Valves

Remove tension plugs (48) and remove tension spring (45) with snap-ring tongs or any other pull-out device diameter 22 mm. Take out discharge valves (46), pulling them upwards out of the valve casing (43). Remove suction valves (46) in the same manner.

Loosen valve seats (46A) from spacer pipe (46D) by lightly hitting the valve plate (46B) with a plastic dowel. Check sealing surfaces and replace worn parts.

Reassemble (preferably) with new O-rings (44A) and support rings (44B); before installing oil elastomers.

Tighten tension plugs (48) to 107 ft.-lbs. (145 Nm).

To Check Seals and Plunger Pipe

Loosen the 8 nuts (49A) and pull off valve casing (43) to the front. Pull seal sleeves (35) out of guides in crankcase (1). Remove seal case (37) and tension spring (42) from seal sleeve.

Check plunger surface and seals (36/40).

If plunger pipe (29B) is worn out, loosen tension screws (29C) and pull off plunger pipe to the front.

Clean front surface of plunger (25) thoroughly.

Then place new plunger pipe carefully through the oiled seals (36/40) and push seal sleeve (35) with plunger pipe into the crankcase guide. Turn gear until the plunger (25) comes up against the plunger pipe.

Put a new copper gasket (29D) onto tension screw (29C). Put a thin coat of glue (Loctite) on the gasket and tighten screw to 26 ft.-lbs. (35 Nm).

IMPORTANT! Care must be taken that no glue gets between the plunger pipe (29B) and the centring sleeve (29A). The plunger pipe should not be strained by eccentric tightening of the tension screw (29C) or through damage to front surface of plunger, otherwise it could break. Tighten the hexagon nuts (49A) for the valve casing (43) evenly at 59 ft.-lbs. (80 Nm).

To Dismantle Gear

After removing valve casing (43) and plunger pipe (29B), drain oil. Remove gear cover (4) and bearing cover (14). Loosen connecting rod (24) screws and push the front of the connecting rod forward as far as possible into the crosshead guide.

IMPORTANT! Connecting rods are marked for identification. Do not twist connecting rod halves. Connecting rods are to be reinstalled in the same position on crankshaft journals.

Turning the crankshaft (22) slightly, hit it out carefully to the side with a rubber hammer.

IMPORTANT! Do not bend the connecting rod shanks. Check crankshaft and connecting rod surfaces, shaft seals (15) and taper roller bearings (20).

To Reassemble

Using a soft tool, press in the outer bearing ring till the outer edge lines up with the outer edge of the bearing hole. Remove bearing cover (14) together with shaft seal (15) and O-ring (16). Fit crankshaft through bearing hole on the opposite side. Press in outer bearing and tension it inwards with the bearing cover, keeping the crankshaft in vertical position and turning slowly so that the taper rollers of the bearings touch the edge of the outer bearing ring. Adjust axial bearing clearance to at least 0.1mm and maximum 0.15mm by placing fitting discs (20A/20B/20C) under the bearing cover.

IMPORTANT! After assembly has been completed, the crankshaft should turn easily with very little clearance. Tighten connecting rod screws to 22 ft.-lbs. (30 Nm).

LP121-5100HT(C) PUMP TORQUE SPECIFICATIONS

Position	Item#	Description	Lubrication Info	Torque Amount
1	05198	Crankcase	Molykote Cu-Paste	
6	07186	Oil Sight Glass Assembly	Loctite 572	29 ft.-lbs. (40 Nm)
10	01010-0100	Hexagon Socket Screw		221 in.-lbs. (25 Nm)
12	07109-0400	Oil Drain Plug		29 ft.-lbs. (40 Nm)
17	07114-0100	Hexagon Screw		221 in.-lbs. (25 Nm)
24	13340	Connecting Rod Screws		22 ft.-lbs. (30 Nm)
29C	07131-0100	Plunger Bolt	Loctite 243	26 ft.-lbs. (35 Nm)
31A	06118	Oil Seal	Loctite 648	
48	06077-0100	Valve Plug		107 ft.-lbs. (145 Nm)
49A	07158	Nut, Stud Bolt		59 ft.-lbs. (80 Nm)
49	07157	Stud Bolt	Loctite 270	

NOTE: Contact Giant Industries for Service School Information. Phone: (419)-531-4600

DIMENSIONS - IN (MM)

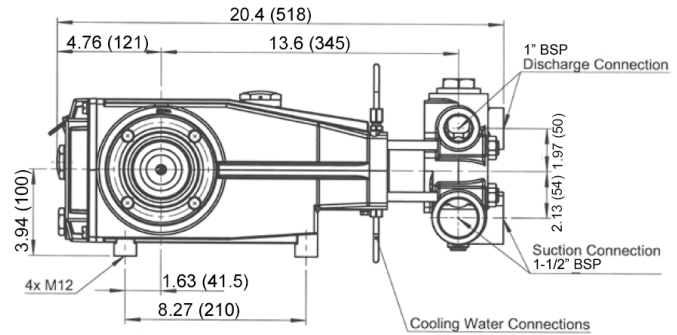
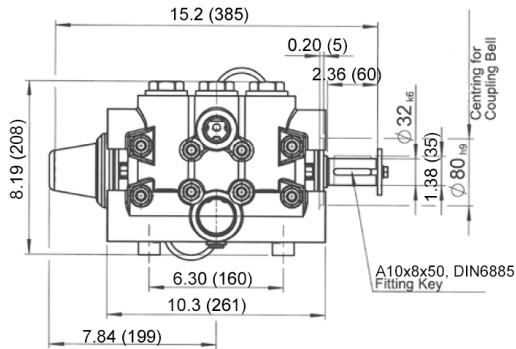

GIANT INDUSTRIES LIMITED WARRANTY

Giant Industries, Inc. pumps and accessories are warranted by the manufacturer to be free from defects in workmanship and material as follows:

1. Five (5) years from the date of shipment for all pumps used in portable pressure washers with NON-SALINE, clean water applications.
2. Two (2) years from the date of shipment for Giant pumps used in car wash applications.
3. One (1) year from the date of shipment for all other Giant industrial and consumer pumps.
4. Six (6) months from the date of shipment for all rebuilt pumps
5. Ninety (90) days from the date of shipment for all Giant accessories.

This warranty is limited to repair or replacement of pumps and accessories of which the manufacturer's evaluation shows were defective at the time of shipment by the manufacturer. The following items are NOT covered or will void the warranty:

1. Defects caused by negligence or fault of the buyer or third party.
2. Normal wear and tear to standard wear parts.
3. Use of repair parts other than those manufactured or authorized by Giant.
4. Improper use of the product as a component part.
5. Changes or modifications made by the customer or third party.
6. The operation of pumps and or accessories exceeding the specifications set forth in the Operations Manuals provided by Giant Industries, Inc.

Liability under this warranty is on all non-wear parts and limited to the replacement or repair of those products returned freight prepaid to Giant Industries which are deemed to be defective due to workmanship or failure of material. A Returned Goods Authorization (R.G.A.) number and completed warranty evaluation form is required prior to the return to Giant Industries of all products under warranty consideration. Call (419)-531-4600 or fax (419)-531-6836 to obtain an R.G.A. number.

Repair or replacement of defective products as provided is the sole and exclusive remedy provided hereunder and the MANUFACTURER SHALL NOT BE LIABLE FOR FURTHER LOSS, DAMAGES, OR EXPENSES, INCLUDING INCIDENTAL AND CONSEQUENTIAL DAMAGES DIRECTLY OR INDIRECTLY ARISING FROM THE SALE OR USE OF THIS PRODUCT.

THE LIMITED WARRANTY SET FORTH HEREIN IS IN LIEU OF ALL OTHER WARRANTIES OR REPRESENTATION, EXPRESS OR IMPLIED, INCLUDING WITHOUT LIMITATION ANY WARRANTIES OR MERCHANTABILITY OR FITNESS FOR A PARTICULAR PURPOSE AND ALL SUCH WARRANTIES ARE HEREBY DISCLAIMED AND EXCLUDED BY THE MANUFACTURER.



WARNING: This product might contain a chemical known to the State of California to cause cancer, and birth defects or other reproductive harm.
For more information go to www.P65Warnings.ca.gov

GIANT
Performance Under Pressure

GIANT INDUSTRIES, INC., 900 N. Westwood Avenue, Toledo, OH 43607
PHONE: (419) 531-4600, FAX: (419) 531-6836, www.giantpumps.com
© Copyright 2021 Giant Industries, Inc.