

REPAIR INSTRUCTIONS - P470/P470-7000/P490/P490-7000 PUMPS

To Check Valves

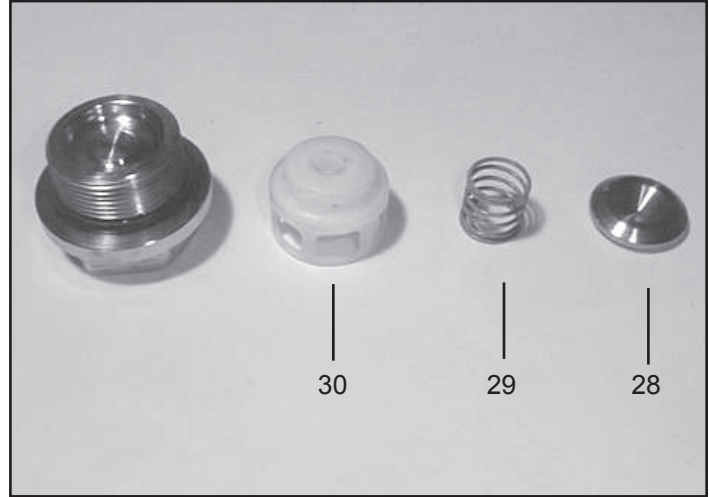

1. Remove plugs (32) with socket wrench.
2. Remove the exposed spring tension cap (30) from valve seat by pushing it sideways with a screwdriver. Remove spring tension cap (30), valve spring (29), and valve plate (28).

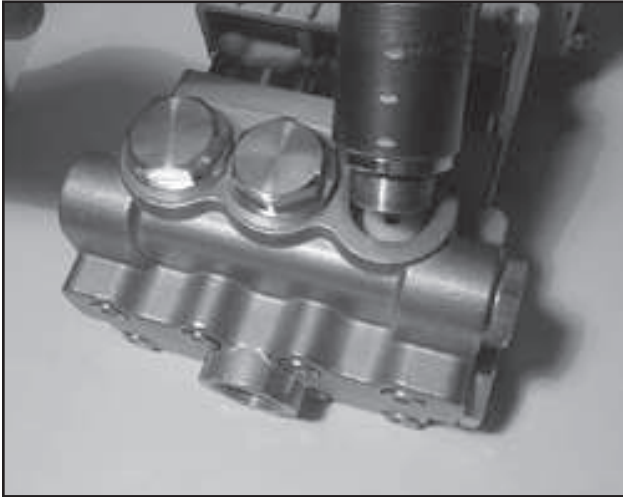
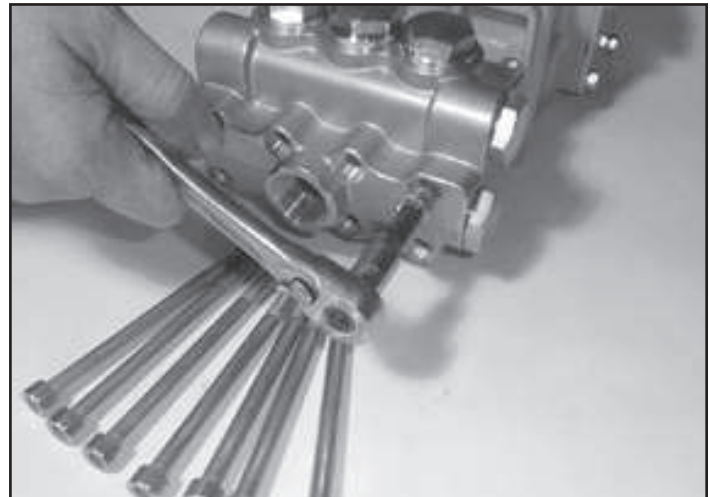
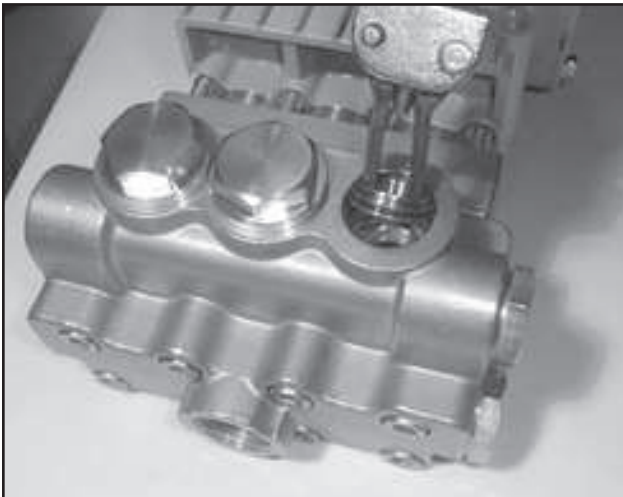

3. Pull out valve seat (27) and O-ring (31) with a valve puller. Check O-ring for wear.
4. Remove hexagon socket screws (34) and remove valve casing (26) by pulling them front-wise over the plungers (16).

REPAIR INSTRUCTIONS - P470/P470-7000/P490/P490-7000 PUMPS

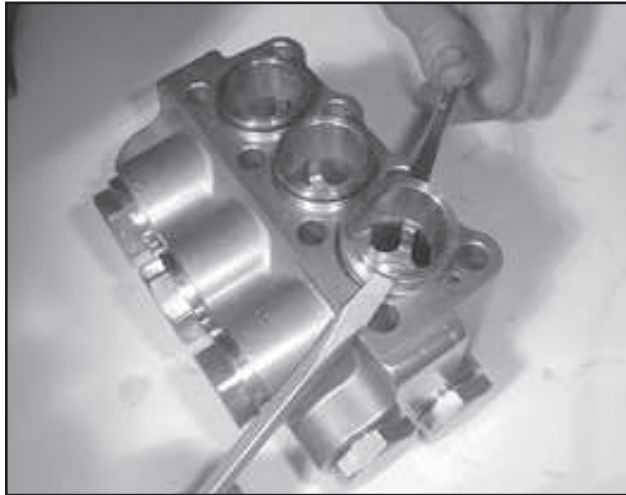

5. Using two screwdrivers, remove seal case (21) out of the valve casing (26) or intermediate casing (25).

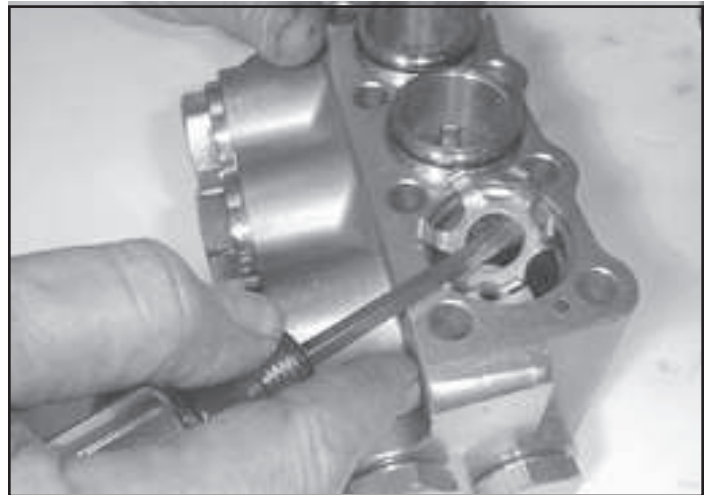

6. The exposed suction valve parts are to be removed the same way as the discharge valves as described above. Check valve components for wear and damage. Check O-rings (21A, 31, 33). Replace worn parts. Reassemble in same order. Coat new o-rings with oil before installation. Coat O-rings (25B) with silicon grease and place them in their recesses. Insert seal cases (21) into valve casing (26) before mounting the whole unit. Slide valve casing (26) over plungers. Tighten hexagon socket screws (34) crosswise and evenly at 36 ft-lbs. Tighten plugs (32) at 125 ft.-lbs. (170 Nm).

Important: When extracting the valve holders (22), make sure not to scratch the outer bore diameter as this is a sealing.

To Check To Check Seals and Plunger Pipe

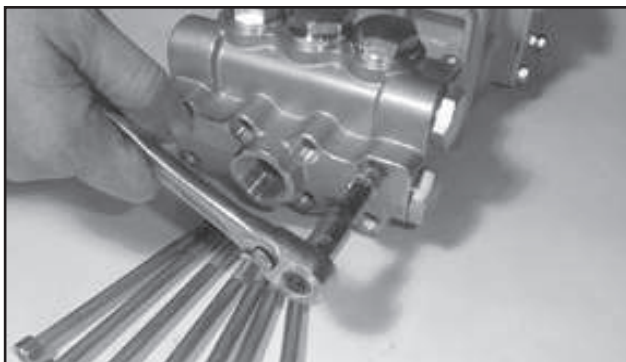

7. Remove hexagon socket screws (34) and remove valve casing (26) by pulling them frontwise over the plungers (16).



8. Using two screwdrivers, gently pry seal cases (21) out of the valve casing (26) or intermediate casing (25). Press groove rings (23) and support rings (24) out of intermediate casing (25) using a screwdriver. Check O-rings (21A/25B). Examine seals (23). Replace worn seals.

REPAIR INSTRUCTIONS - P470/P470-7000/P490/P490-7000 PUMPS

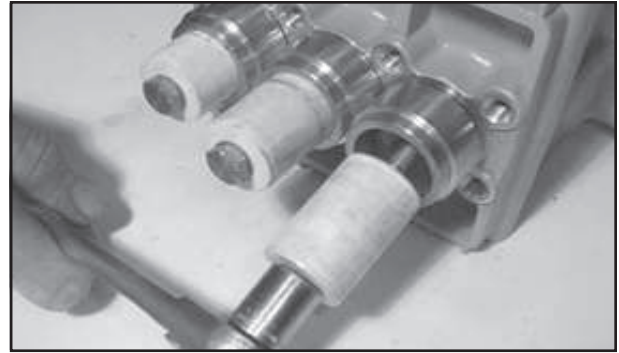
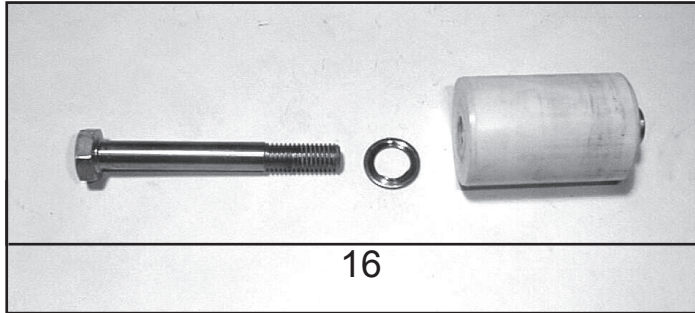

9. Check plunger surfaces (16). Damaged surfaces lead to accelerated seal wear. Deposits of all kinds must be removed from the plungers.

Important: Plunger surfaces are not to be damaged. If there are lime desposits in the pump, care must be taken that the weep-return bore in parts (25) and (26) ensure trouble-free weep-return.

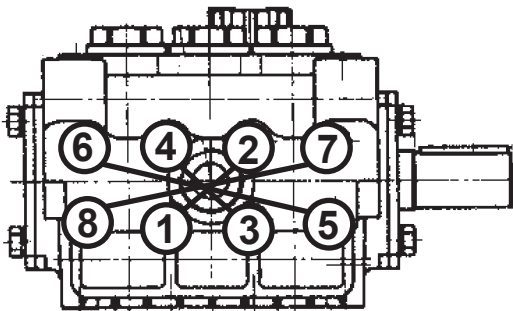

10. If the plunger pipe (16B) is worn, remove tension screw (16D) and remove together with plunger pipe. Check and clean plunger (16A) surfaces and mount new plunger pipe. Cover thread of tension screw (16D) with a thin film of Loctite and tighten carefully at 248 in.-lbs. (28 Nm).

Important: Glue must never come between the plunger pipe (16B) and the centring sleeve (16C). The plunger pipe is not to be strained by eccentric tightening of the tension screw or through damage to the front surface as this can lead to breakage.

11. When reassembling, tighten inner hexagon screw (34) at 30 ft.-lbs. (40 Nm) in a crossing pattern (as shown on left).

Gear and Plunger

If oil leaks where the plungers (16) protrude out of the gear, gear seals (19) and plungers must be examined and replaced if necessary.

- a) **Gear Seal:** Remove oil plug (5) and drain oil. Remove valve casing (26) together with seal casing (25) as described above. Dismantle plunger pipe (16B). Pry gear seal adaptor (20) out of the crankcase using a screwdriver; take out gear seal (19) and replace it.
- b) **Plungers:** Remove oil plug (5) and drain oil; remove crankcase cover (3). Remove valve casing (26), seal casing (25), gear seal adaptors (20) and plunger pipes (16B) as described above. Remove screws on conn-rods (15). Be careful not to mix up the connecting rod halves. Push connecting rod shaft as far as possible into the crosshead guide. Take off screws (10) and pry out bearing covers (7 & 8) with the help of a screwdriver. Take out crankshaft carefully threading it past the conrods (15), making sure not to bend the connecting rods. Remove and dismantle connecting rods and plungers (16). Replace worn parts. Reassemble and tighten tension screws (16D) at 248 in.-lbs. (28 Nm). When reinstalling, first insert connecting rods together with plungers. Thread in crankshaft. Then push bearing covers (7 & 8) onto the crankshaft ends. Screw on bearing covers with screws (10). Mount connecting rod halves and tighten screws (15) at 22 ft.-lbs. Mount crankcase cover (3) together with O-ring (4). Replace seal adaptors (20), seal casing (25) and valve casing (26). Replace eight (8) hexagon screws (34) and tighten to 30 ft.-lbs. (40 Nm).