

Model P465H

Triplex Ceramic
Plunger Pump
Operating Instructions/
Repair and Service Manual

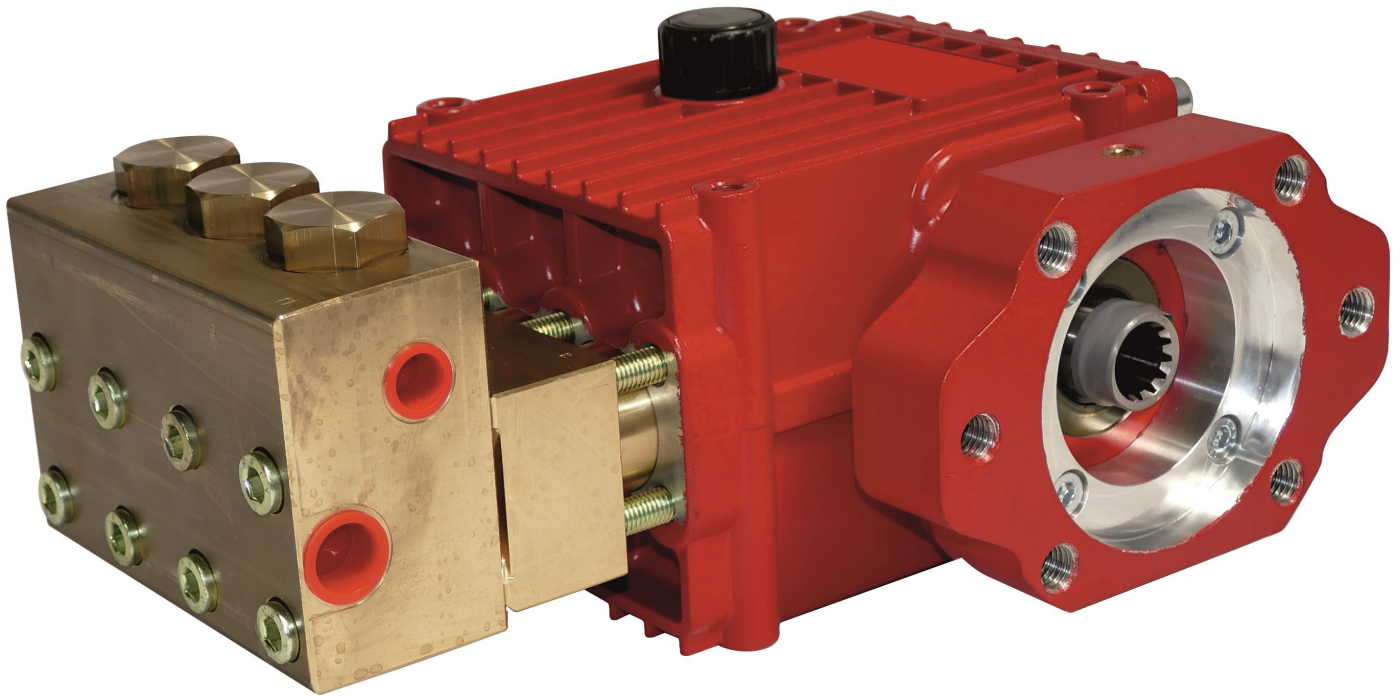

GIANT
Performance Under Pressure

Contents:

Installation / Operating Instructions:	page 2
Pump Specifications:	page 3
Exploded View:	page 4
Parts List, Kits:	page 5
Torque Requirements:	page 5
Maintenance Instructions:	page 6
Dimensions:	page 7
Warranty Information	back page

INSTALLATION INSTRUCTIONS

Required NPSH refers to water (specific weight 1kg/dm^3 , viscosity 1°E) and maximum permissible pump revolutions.

Operation and Maintenance

Check oil level prior to starting and ensure trouble-free water supply.

Important! If there is a danger of frost, the water in the pump and in the pump fittings (particularly the unloader valve) must be emptied. The second discharge port can be used and the pump run "dry" for 1-2 minutes for this purpose.

Oil: Use only 27.1 fluid ounces (0.8 liters) of ISO VG 220 GL4 (e.g. Aral Degol BG220) or SAE 90 GL4 gear oil (Giant p/n 01154).

Initial oil change after 50 operating hours and then every 500 hours, after 1 year if used less.

Caution: When operating in damp places or with high temperature fluctuations, oil must be changed immediately [should condensate (frothy oil) occur in the gear box].

NPSH values must be observed.

Maximum input pressure 145 PSI (10 bar), maximum suction head -4.35 PSI (-0.3 bar). Make sure that suction pulsation is sufficiently dampened - water column resonance must be avoided.

Important! If the pump is not used for a long period of time, it is possible the seals (23) could become hard or brittle thus causing the pump to leak when put into operation.

If this is the case, we recommend these seals be replaced every 4 years.

Safety Rules

A safety valve is to be installed in accordance with the guidelines for liquid spraying units so that the admissible operating pressure cannot be exceeded by more than 10%. Pump operation without a safety valve as well as any excess in temperature or speed limits automatically voids the warranty.

When the pump is in operation, the drive shaft end and the coupling must be enclosed by a protective cover or a coupling bell.

Pressure in the discharge line and pump must be at zero before any maintenance to the pump takes place. Close suction line. Disconnect fuses to ensure that the driving motor does not get switched on accidentally.

Make sure that all parts on the pressure side of the unit are vented before starting the pump. In order to prevent air, or an air-water mixture being absorbed and to prevent cavitation occurring, the pump NPSHR suction head and water temperature must be respected.

Cavitation and/or compression of gases lead to uncontrollable pressure kicks which can ruin pump and unit parts and also be dangerous to the operator or anyone standing nearby.

Giant plunger pumps are suitable for pumping clean water and other non-aggressive or non-abrasive media with a specific weight similar to water.

Before pumping other liquids - especially inflammable, explosive and toxic media - the pump manufacturer must be consulted with regard to the resistance of the pump material. It is the responsibility of the equipment manufacture and/or operator to ensure that all pertinent safety regulations are adhered to.

Specifications Model P465H

	U.S.	Metric
Volume	6.3 GPM	23.9 L/min
Discharge Pressure	5800 PSI	400 Bar
Max. Inlet Pressure	-4.35 to 145 PSI	-0.3 to 10 bar
Power Required	25.2 BHP	18.8 kW
Maximum Crankshaft Rotation Speed	Up to 1450 RPM	
Stroke	0.94"	24 mm
Crankcase Oil Capacity	27.1 fl.oz.	0.8 Liters
Temperature of Pumped Fluids	Up to 104 °F	40 °C
Plunger Diameter	0.71"	18 mm
Inlet Ports	(2) 1/2" BSP	
Discharge Ports	(2) 3/8" BSP	
Crankshaft Bore	SAE 2B or SAE 4B 13T 16/32 Spline*	
Shaft Rotation	Towards fluid end	
Weight	37.5 lbs	17 kg
Volumetric Efficiency @ 1450 RPM	0.90	
Mechanical Efficiency @ 1450 RPM	0.80	

* J498b 30° Class 5

Consult the factory for special requirements that must be met if the pump is to operate beyond one or more of the limits specified above.

P465 HORSEPOWER REQUIREMENTS				
RPM	GPM	4000 PSI	5000 PSI	5800 PSI
1000	4.3	12.0	15.0	17.4
1100	4.8	13.2	16.4	19.1
1200	5.2	14.4	18.0	20.8
1300	5.6	15.6	19.4	22.6
1450	6.3	17.4	21.7	25.2

NOTE:

In order to drive the pump from the side opposite the present shaft extension, simply remove the valve casing from the crankcase and rotate the pumps 180 degrees to the desired position. Be certain to rotate the seal case (item #20) as well, so that the weep holes are down at the six o'clock position. Exchange the oil fill and the oil drain plugs, also. Refer to the repair instructions as necessary for the proper assembly sequence.

Horsepower Ratings:

Horsepower ratings shown are the power requirements for the pump. Gas engine power outputs must be approximately twice the pump power requirements shown above. We recommend that a 1.15 service factor be specified when selecting an electric motor as the power source. To compute specific pump horsepower requirements, use the following formula: (GPM X PSI) / 1450 = HP

For the Application of a Hydraulic Motor:

To Determine the Torque of a Hydraulic Motor -- (GPM x PSI x 36.77) / RPM = Torque (in-lbs)

Exploded View - P465H

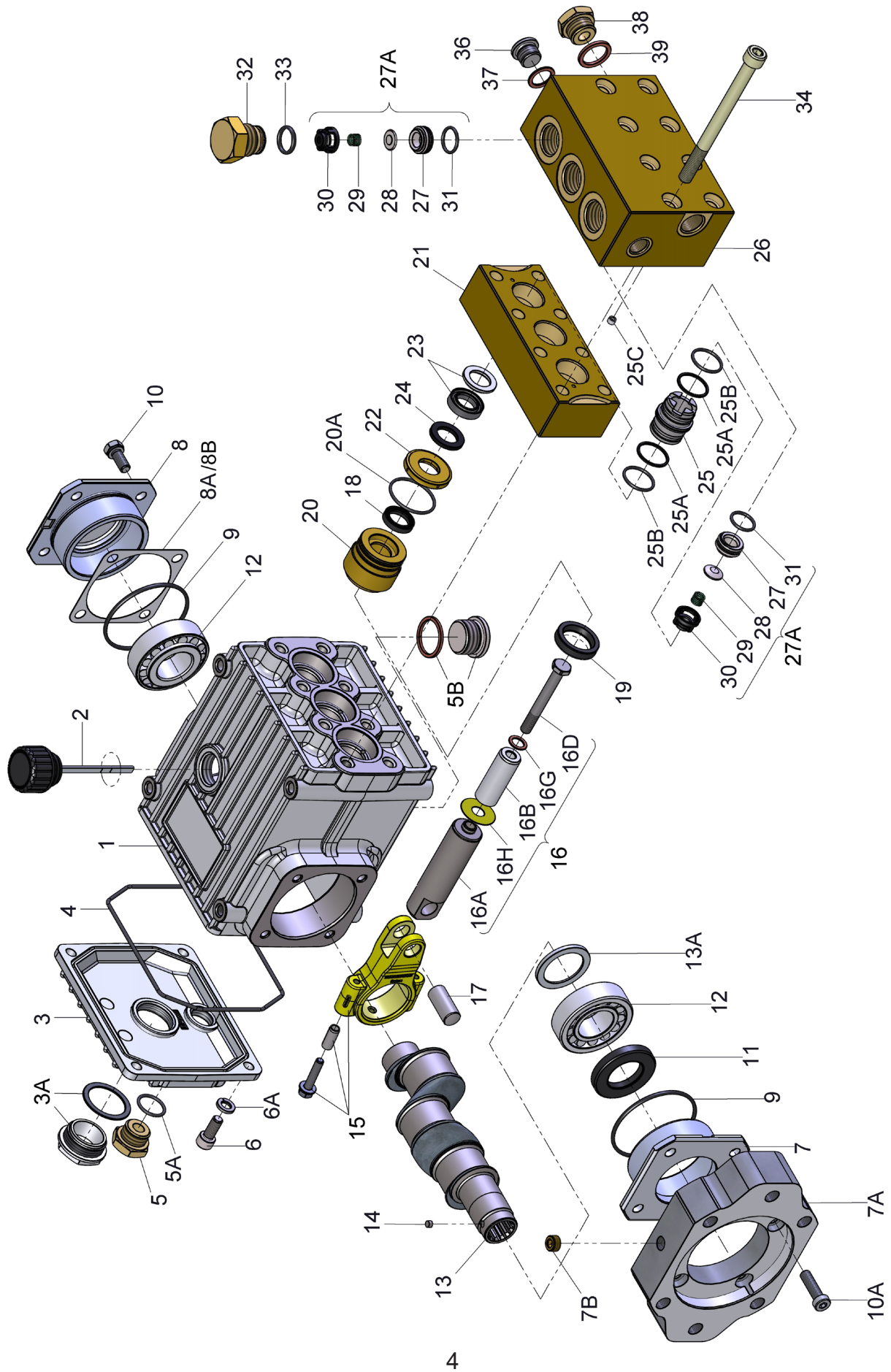

P465H PARTS LIST

<u>ITEM</u>	<u>PART</u>	<u>DESCRIPTION</u>	<u>QTY.</u>	<u>ITEM</u>	<u>PART</u>	<u>DESCRIPTION</u>	<u>QTY.</u>
1	08377	Crankcase	1	16G	07676	Copper Gasket	3
2	08378	Oil Fill Plug with Gasket	1	16H	06431	Oil Scraper	3
3	06479	Crankcase Cover	1	17	06790	Crosshead Pin	3
3A	07186	Oil Sight Glass w/Gasket	1	18	08477	Grooved Seal	3
4	08380	O-Ring	1	19	05444	Oil Seal	3
5	07109	Oil Drain Plug, 1/2" BSP	1	20	05534	Seal Adapter	3
5A	06015	O-Ring	1	20A	07266	O-Ring	3
5B	08092	Plug with Gasket	1	21	05535	Seal Casing	1
6	01010	Screw	4	22	05536	Drip Return Ring	3
6A	01011-4000	Spring Washer	4	23	05517	Grooved Seal Packing	3
7	04739	Bearing Cover Open	1	24	05537	Support Ring	3
7A	03266	Motor Flange	1	25	05547	Seal Case	3
7B	03267	Plug, M12 x 1	1	25A	05538	Support Ring for O-Ring	6
8	05291	Bearing Cover Closed	1	25B	07489	O-Ring	6
8A	05292	Shim	1-3	25C	05539	Border Seal Ring	2
8B	05293	Shim	1-2	26	05516	Valve Casing	1
9	01016	O-Ring	2	27A	05543	Valve Assembly (Items 27-31)	6
10	07114	Screw with Washer	4	27	05541	Valve Seat	6
10A	07774	Hexagon Socket Screw	4	28	05542	Valve Plate	6
11	07459	Radial Shaft Seal	1	29	07906	Valve Spring	6
12	05350	Bearing	2	30	07907	Valve Spring Retainer	6
13	03268	Crankshaft	1	31	07770	O-Ring	6
13A	04742	Spacer Ring	1	32	05544	Plug, M25x1.5	3
14	03269	Magnet	1	33	05545	O-Ring	3
15	08390	Connecting Rod Assembly	3	34	05546	Cap Screw	8
16	05531	Plunger Assembly (16A-16H)	3	36	12256	Plug, 3/8" BSP	1
16A	05352	Plunger	3	37	08486	Copper Washer	1
16B	05532	Plunger Pipe	3	38	07109	Plug, 1/2" BSP	1
16D	05533	Tension Screw	3	39	06272	Copper Washer	1

P465 / P485 REPAIR KITS

Plunger Packing Kits

Part # 09640

<u>Item</u>	<u>Part #</u>	<u>Description</u>	<u>Qty.</u>
18	08477	Grooved Seal	3
20A	07266	O-Ring	3
23	05517	Grooved Seal Packing	3
24	05537	Support Ring	3
25A	05538	Support Ring for O-ring	6
25B	07489	O-Ring	6
25C	05539	Border Seal Ring	2

Valve Repair Kits

Part # 09781

<u>Item</u>	<u>Part #</u>	<u>Description</u>	<u>Qty.</u>
27A	05543	Valve Assembly	6
33	05545	O-Ring	3

Oil Seal Kit

Part # 09641

<u>Item</u>	<u>Part #</u>	<u>Description</u>	<u>Qty.</u>
19	05444	Oil Seal	3

P465 / P485 TORQUE SPECIFICATIONS

<u>Item</u>	<u>Part #</u>	<u>Description</u>	<u>Lubrication Info</u>	<u>Torque Amount</u>
3A	07186	Oil Sight Glass w/Gasket	Loctite 5910	106 in.-lbs. (12 Nm)
5	07109	Oil Drain Plug		59 ft.-lbs. (80 Nm)
5B	08092	Plug with Gasket		59 ft.-lbs. (80 Nm)
6	01010	Screw		110 in.-lbs. (12.5 Nm)
5B	08092	Plug with Gasket		59 ft.-lbs. (80 Nm)
10	07114	Screw with Washer		132 in.-lbs. (15 Nm)
10A	07774	Hexagon Socket Screw		97 in.-lbs. (11 Nm)
15	08390	Connecting Rod Assembly		97 in.-lbs. (11 Nm)
16D	05533	Tension Screw	Loctite 243	247 in.-lbs. (28 Nm)
32	05544	Plug		125 ft.-lbs. (170 Nm)
34	05546	Cap Screw	Lightly Oil	30 ft.-lbs. (40 Nm)

MAINTENANCE INSTRUCTIONS - P465H

1. Inlet and Discharge Valves

Unscrew plugs (32) using a 32mm socket wrench. Using a pair of flat pliers, remove the discharge valve assemblies (27A). Disassemble valve assemblies. Unscrew (8) hexagon socket screws (34) and remove valve casing (26) by pulling off to the front. Remove inlet valve assemblies (27A) with flat pliers and disassemble. Examine spring tension caps (30,30A), valve springs (29), valve plates (28), valve seats (27) and o-rings (31,33). Replace worn parts. Take care to reassemble in the correct order. Coat the threads of plug (32) with *Loctite* and tighten to 125 ft.-lbs. (170 NM).

2. Seals

Remove the seal cases (25) from the seal casing (21) and examine o-rings (25A) and support rings (25B). The seal case (25) has a groove which enables one to pry it out with two standard screwdrivers. Remove seal adapter (20) from the seal casing. Check o-rings (20A), grooved rings (18) and grooved seal pack (23) and the guide rings (24) for wear. Grease new seal rings and o-rings with a light coating of lubricant.

IMPORTANT Mounting tools are available for fitting the seals into the seal casing and seal adapters. If mounting tools are not available carefully insert the grooved seal pack (23) little by little into the bore of the seal casing by using the flat side of a screwdriver, making sure that the seal lip faces into the seal casing (21). Press grooved seal (18), flat side first, into the seal retainer. Under no circumstances must the seal surface in the valve casing or the seal lip of the grooved seal be damaged.

Carefully check the surfaces of the plungers (16B). Damaged surfaces cause accelerated seal wear. Deposits of all kinds must be removed from the plungers. Plunger surfaces must not be damaged during this procedure. If there are lime deposits in the pump, care must be taken that the drip-return bores in parts (21) and (28) are open to ensure trouble-free drip return.

If the plunger pipe (16B) is worn, loosen tension screw (16D) and remove together with plunger pipe. Check and clean plunger surface (16A), check oil scraper (16H) and replace with new plunger pipe and copper gasket (16G). Cover thread of tension screw (16D) with a thin film of *Loctite* 243 and tighten carefully to 247 in.-lbs. (28 NM).

IMPORTANT Glue / *Loctite* must never come between the plunger pipe (16B) and the centring support on the plunger (16A). Deformation of the plunger pipe due to improper tightening of the tension screw as well as dirt or damage on the front surface can fracture the plunger pipe. When remounting the valve casing, tighten the hexagon socket screws (34) to 30 ft.-lbs. (40 NM).

3. Gear End

If oil leaks where the plunger (16) extends from the crankcase (1), the oil seals (19) and plungers (16) must be examined and replaced if necessary. Remove oil plug (5) and drain oil; remove crankcase cover (3). Remove valve casing (26), seal casing (21) and seal adapters (20). Then remove plunger pipes (16B) and oil scrapers (16H) as described above.

IMPORTANT Before removing connecting rods be aware of their position on the crankshaft so as to return them to the same location when re-assembling.

Remove screws from connecting rods (15), separate the back connecting rod half from the crankshaft and the front connecting rod half by threading a screw into the center back bore of the connecting rod. The connecting rod halves must be kept as pairs - do not mix them up. Push connecting rod shaft as far as possible into the crosshead guide. Remove screws (10) and pry bearing covers (7,8) off gently with a screwdriver.

Remove magnet, then carefully remove crankshaft (13) by threading it through the connecting rods (15), making sure not to bend the connecting rods. Remove and disassemble connecting rods and plungers (16) paying close attention not to damage the plungers. Pry out oil seal (19) using a screwdriver. Examine plunger surfaces (16A) and replace if necessary.

To re-assemble, first press the oil seal (19) into the crankcase. Then insert connecting rods with plungers remembering their original location. Thread in the crankshaft (13). Replace bearing cover (7) and o-ring (9) together with the radial shaft seal (11) and roller bearing (12) and fix in place with screws (10). Replace roller bearing (12), bearing cover (8) and o-ring (9). Adjust the clearance by fitting shims (8A,8B) under the bearing cover as required to ensure that the crankshaft (13) turns easily without play being felt. Finally, mount connecting rod halves on crankshaft matching them with other half and tighten screws (15) to 97 in.-lbs. (11 Nm). Replace crankcase cover (3) and o-ring (4). When remounting the valve casing (26), tighten hexagon socket screws (34) to 30 ft.-lbs. (40 Nm).

4. To Move Crankshaft to Opposite Side

Remove the valve casing (26) and seal casing (21) together with the seal adapters (20) then rotate the crankcase 180°. Interchange the oil plug ((5B) with oil dipstick (2). Rotate the crankcase cover (3) 180°. Remount the valve casing together with the seal casing and the seal adapters (20). Make sure that the seal adapters are rotated in order that the bores face downwards.

P465H Dimensions - Inches (mm)

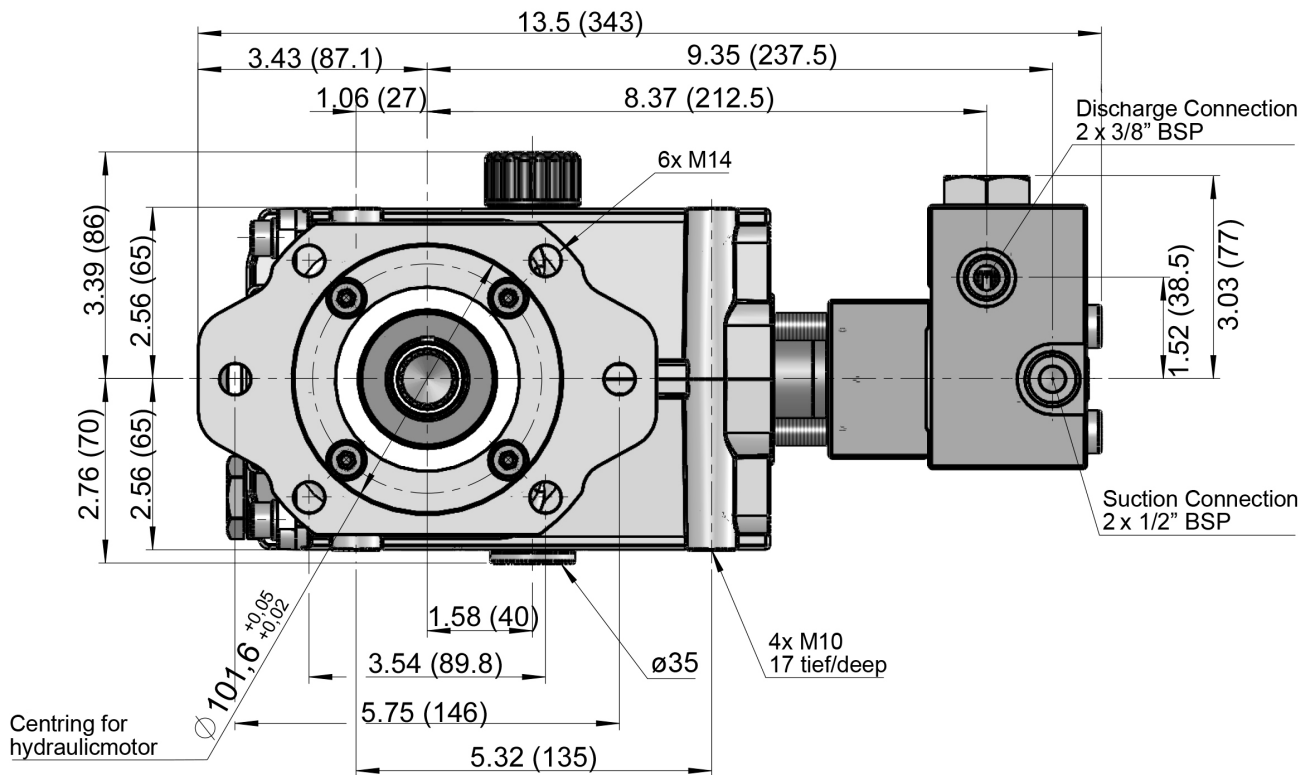
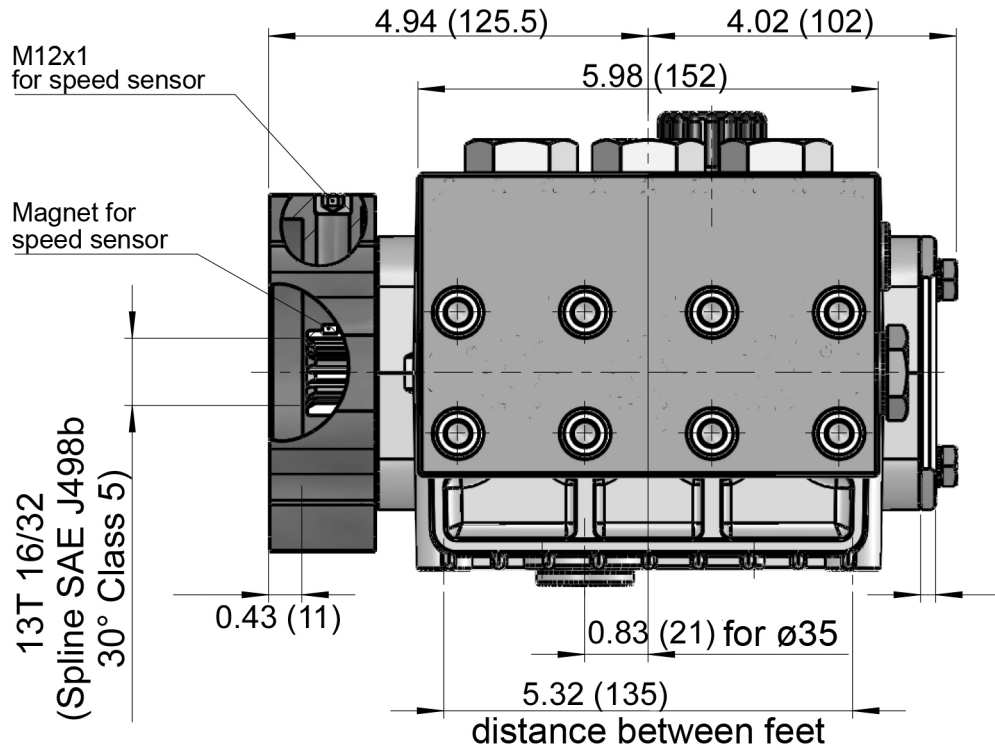

GIANT INDUSTRIES LIMITED WARRANTY

Giant Industries, Inc. pumps and accessories are warranted by the manufacturer to be free from defects in workmanship and material as follows:

1. Five (5) years from the date of shipment for all pumps used in portable pressure washers with NON-SALINE, clean water applications.
2. Two (2) years from the date of shipment for Giant pumps used in car wash applications.
3. One (1) year from the date of shipment for all other Giant industrial and consumer pumps.
4. Six (6) months from the date of shipment for all rebuilt pumps
5. Ninety (90) days from the date of shipment for all Giant accessories.

This warranty is limited to repair or replacement of pumps and accessories of which the manufacturer's evaluation shows were defective at the time of shipment by the manufacturer. The following items are NOT covered or will void the warranty:

1. Defects caused by negligence or fault of the buyer or third party.
2. Normal wear and tear to standard wear parts.
3. Use of repair parts other than those manufactured or authorized by Giant.
4. Improper use of the product as a component part.
5. Changes or modifications made by the customer or third party.
6. The operation of pumps and or accessories exceeding the specifications set forth in the Operations Manuals provided by Giant Industries, Inc.

Liability under this warranty is on all non-wear parts and limited to the replacement or repair of those products returned freight prepaid to Giant Industries which are deemed to be defective due to workmanship or failure of material. A Returned Goods Authorization (R.G.A.) number and completed warranty evaluation form is required prior to the return to Giant Industries of all products under warranty consideration. Call (419)-531-4600 or fax (419)-531-6836 to obtain an R.G.A. number.

Repair or replacement of defective products as provided is the sole and exclusive remedy provided hereunder and the MANUFACTURER SHALL NOT BE LIABLE FOR FURTHER LOSS, DAMAGES, OR EXPENSES, INCLUDING INCIDENTAL AND CONSEQUENTIAL DAMAGES DIRECTLY OR INDIRECTLY ARISING FROM THE SALE OR USE OF THIS PRODUCT.

THE LIMITED WARRANTY SET FORTH HEREIN IS IN LIEU OF ALL OTHER WARRANTIES OR REPRESENTATION, EXPRESS OR IMPLIED, INCLUDING WITHOUT LIMITATION ANY WARRANTIES OR MERCHANTABILITY OR FITNESS FOR A PARTICULAR PURPOSE AND ALL SUCH WARRANTIES ARE HEREBY DISCLAIMED AND EXCLUDED BY THE MANUFACTURER.



WARNING: This product might contain a chemical known to the State of California to cause cancer, and birth defects or other reproductive harm.
For more information go to www.P65Warnings.ca.gov

Giant Industries, Inc.
900 N. Westwood Ave.
Toledo, OH 43607
419-531-4600
419-531-6836 Fax
www.giantpumps.com

© Copyright 2020 Giant Industries, Inc.

GIANT
Performance Under Pressure

10/20 P465H.indd