

REPAIR INSTRUCTIONS - P300 SERIES - 12 and 20 MM VERSIONS

NOTE: Always take time to lubricate all metal and nonmetal parts with a light film of oil before reassembly. This step will ensure proper fit, at the same time protecting the pump nonmetal parts (i.e., the elastomers) from cutting and scoring.

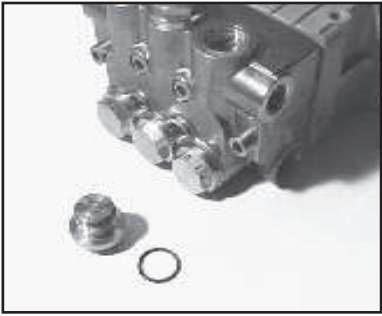

1. With a 24mm socket wrench, remove the (3) discharge valve plugs and (3) inlet valve plugs (#32). Inspect the o-ring (#33) for wear and replace if damaged.



2. Using a needle nose pliers, remove the inlet and discharge valve assemblies (#32X).



3. The valve assemblies can be separated by inserting a small screw driver between the valve seat (#27) and its valve spring retainer (#30).



4. Remove each o-ring (#31). Inspect all parts for wear and replace as necessary. Reassemble valve assy's (#32X) & place in valve casing (#26).

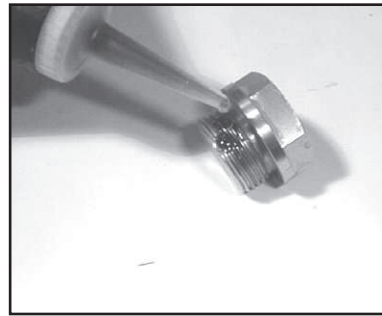

5. Apply one drop of Loctite 243 to valve plugs (#32) and tighten to 55 ft.-lbs. (75 Nm).

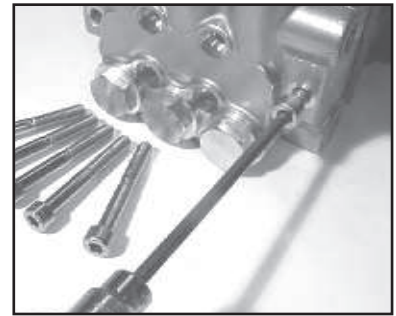

6. Next, use a 6mm allen wrench to remove the 6 hex head cap screws (#34).

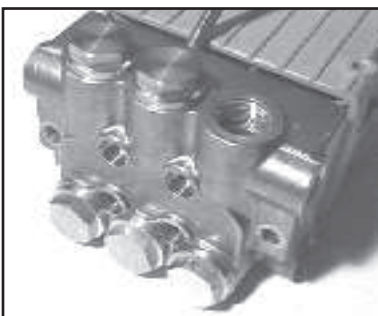

7. Carefully slide the valve casing (#26) out over the plungers with a screwdriver placed between the valve casing and crankcase.



8. Remove weep return rings (#25) from the plungers (#16). Remove the seal case (#20) from either crankcases (#1) or manifold (#26) by using a screwdriver as shown above.

NOTE: If there are deposits of any kind (i.e., lime deposits) in the valve casing, be certain the weep holes in the weep return ring (#25) and valve casing (#26) have not been plugged.

REPAIR INSTRUCTIONS - P300 SERIES - 12 and 20 MM VERSIONS

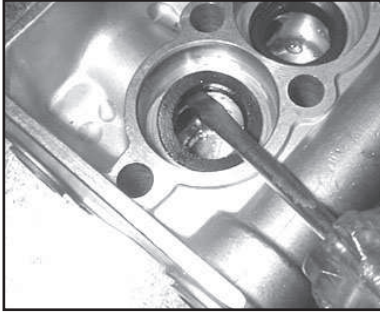

9. Remove the pressure rings (#24) and grooved seals (#23) from the valve casing (#26). Inspect parts for wear and replace if necessary.



10. Remove the weep grooved seals (#23A for P314, P321 & P327 and #23 for P318, P324 & P330) from the seal case (#20).

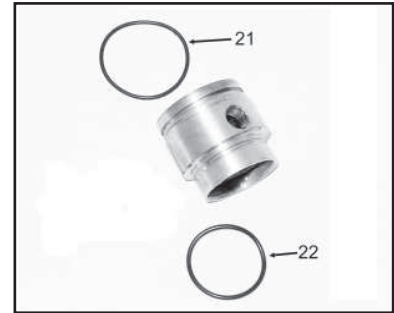

11. Inspect o-rings (#21 and 22) and replace as necessary.



12. For P314, P321 & P327 pumps, use a flat screw driver to pry the oil seals (#19) loose from the seal case (#20).

For P318/P324/P330 Pumps

Note: Occasionally, the above procedure can be carried out for P318/P324/P330 pumps. However, for P318/P324/P330 pumps which have the oil seals that remain in the crank-case, use a 6mm allen wrench to first loosen and remove the tension screw (#16C) from the plunger pipes (#16B). Use a flat screwdriver to pry the oil seals loose from the crank-case (#1).

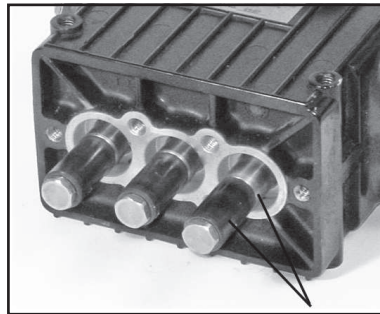

13. Check surfaces of the plunger bases and plunger pipes (#16B). A damaged surface will cause accelerated wear on the seals. Deposits of any kind must be carefully removed from the plunger surface. A damaged plunger must be replaced!

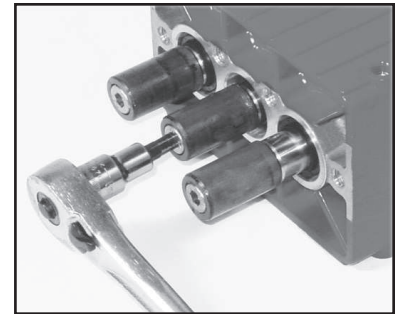

- 13A. **P318/P324/P330 Only!**
Clean the old sealant from the threads of the tension screw and the plunger base (#16A). Replace the copper washer (#16D). Place plunger pipes over plunger base and secure with tension screw to 199 in-lbs. (22.5 Nm).

REPAIR INSTRUCTIONS - P300 SERIES - 12 and 20 MM VERSIONS

Reassembly sequence of the P300 Series pump

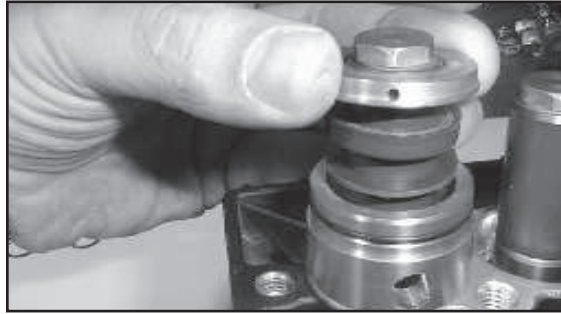
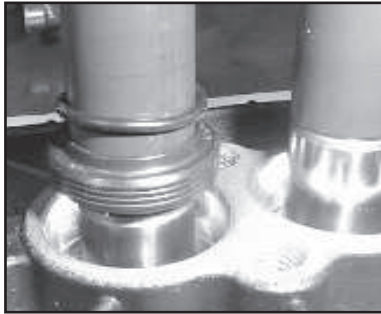

14. If the oil seals (#19) were removed, replace them with the primary seal lip (grooved side) towards the crankcase and the dust lip (tapered end) towards the valve casing (#26). Lubricate the seal before replacing. For P318, P324 and P330, install the oil scraper (#18) over the plunger.
15. Place each seal case (#20) with o-rings (#21, 22) over the plungers (#16). Be certain the oil seal is centered with the seal case and tap firmly until the seal case is seated squarely on the crankcase (#1).
16. With the grooved side pointed toward the valve casing, place the weep grooved seals (#23A for P314, P321 and P327 pumps & #23 for P318, P324, and P330) over each plunger and into each seal case (#20).
17. Generously lubricate the grooved seals (#23) and assemble these items into the valve casing. Place the weep return rings (#25) onto each plunger (#16). Place the pressure rings (#24) over the plungers. Slide the valve casing over the plungers and seat firmly. Replace the 6 hex head cap screws (#34) and tighten to 222 in.-lbs. (25 Nm) in a crossing pattern.

Contact Giant Industries or you local distributor for maintenance of the gear end of your pump. Phone: 419/531-4600