

Model GP7155HTC

Triplex Ceramic
Plunger Pump
Operation Manual

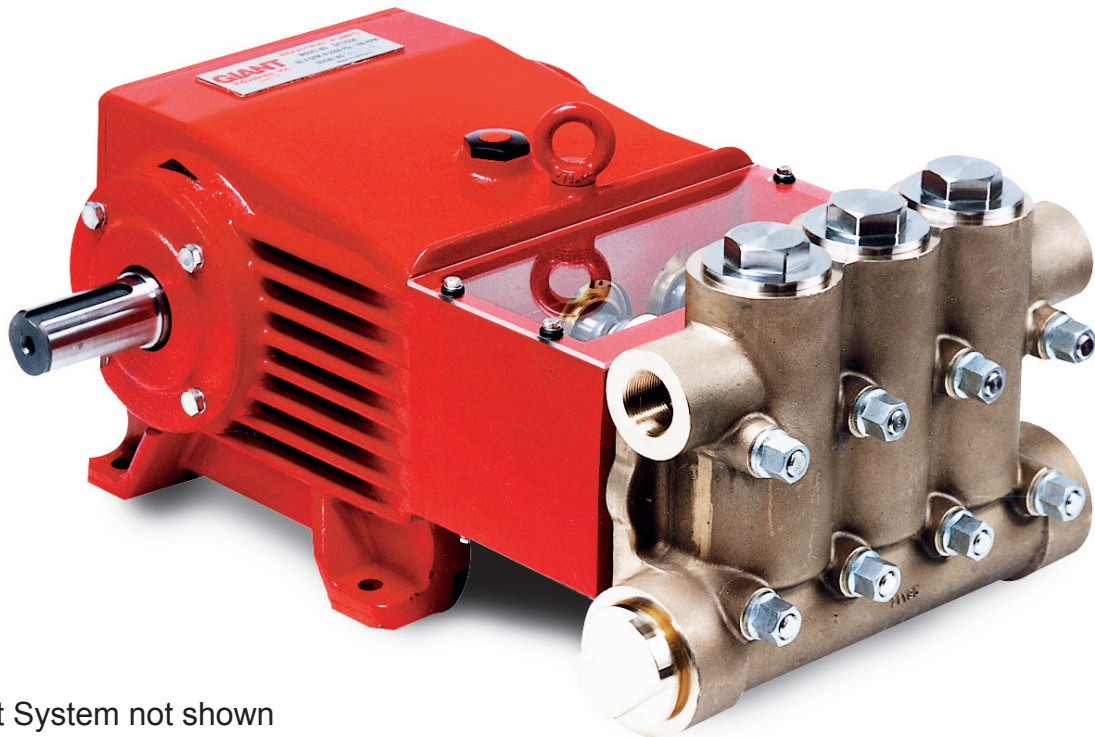

Coolant System not shown

Contents:

Installation Instructions	page 2
Pump Specifications:	page 3
Exploded View:	page 4
Parts List:	page 5
Kits/Torque Specifications:	page 6
Maintenance Information:	page 6
Repair Instructions:	page 7
Dimensions:	back page
Warranty Information	back page

INSTALLATION INSTRUCTIONS

Installation of the Giant Industries, Inc., pump is not a complicated procedure, but there are some basic steps common to all pumps. The following information is to be considered as a general outline for installation. If you have unique requirements, please contact Giant Industries, Inc. or your local distributor for assistance.

1. The pump should be installed flat on a base to a maximum of a 15 degree angle of inclination to ensure optimum lubrication.
2. The inlet to the pump should be sized for the flow rate of the pump with no unnecessary restrictions that can cause cavitation. Teflon tape should be used to seal all joints. If pumps are to be operated at temperatures in excess of 221° F (105° C), it is important to insure a positive head to the pump to prevent cavitation.
3. The discharge plumbing from the pump should be properly sized to the flow rate to prevent line pressure loss to the work area. It is essential to provide a safety bypass valve between the pump and the work area to protect the pump from pressure spikes in the event of a blockage or the use of a shut-off gun.
4. Use of a dampener is necessary to minimize pulsation at drive elements, plumbing, connections, and other system areas. The use of a dampener with Giant Industries, Inc. pumps is optional, although recommended by Giant Industries, Inc. to further reduce system pulsation.

Dampeners can also reduce the severity of pressure spikes that occur in systems using a shut-off gun. A dampener must be positioned downstream from the unloader.

5. Crankshaft rotation on Giant Industries, Inc. pumps should be made in the direction designated by the arrows on the pump crankcase. Reverse rotation may be safely achieved by following a few guidelines available upon request from Giant Industries, Inc. Required horsepower for system operation can be obtained from the charts on page 3.
6. Before beginning operation of your pumping system, remember: Check that the crankcase and seal areas have been properly lubricated per recommended schedules. Do not run the pump dry for extended periods of time. Cavitation will result in severe damage. Always remember to check that all plumbing valves are open and that pumped media can flow freely to the inlet of the pump.

Finally, remember that high pressure operation in a pump system has many advantages. But, if it is used carelessly and without regard to its potential hazard, it can cause serious injury.

IMPORTANT OPERATING CONDITIONS

Failure to comply with any of these conditions invalidates the warranty

1. Prior to initial operation, add oil to crankcase so that oil level is between the two lines on the oil dipstick. **DO NOT OVERFILL.**

Use Giant Recommended Oil (p/n 01154), or the equivalent to SAE 85-90W Industrial Gear Lube.

Crankcase oil should be changed after the first 50 hours of operation, then at regular intervals of 500 hours or less depending on operating conditions.

2. Pump operation must not exceed rated pressure, volume, or RPM. A pressure relief device must be installed in the discharge of the system.

3. Acids, alkalines, or abrasive fluids cannot be pumped unless approval in writing is obtained before operation from Giant Industries, Inc.

4. Run the pump dry approximately 10 seconds to drain the water before exposure to freezing temperatures.

**NOTE: Contact Giant Industries for Service School Information.
Phone: (419)-531-4600.**

Specifications

Model GP7155HTC

	U.S.	(Metric)
Volume.....	42.4 GPM	(160.3 LPM)
Discharge Pressure	1160 PSI.....	(80 bar)
Speed		460 RPM
Inlet Pressure (maximum)	-4.35 to 145 PSI	(-0.3 to 10 bar)
Plunger Diameter.....	2.17"	55mm
Plunger Stroke.....	2.0"	52mm
Crankshaft Diameter.....	1.9"	48mm
Key Width	0.6"	14mm
Crankshaft Mounting		Either side
Shaft Rotation.....	Top of pulley towards manifold	
Temperature of Pumped Fluids	Up to 221 °F	(105 °C)
Inlet Ports		(2) 2-1/2" BSP
Discharge Ports		(2) 1-1/4" BSP
Weight	375 lbs.	(170 kg)
Crankcase Oil Capacity	1.6 Gal.	(6.0 liter)
Fluid End Material.....		Bronze

Consult the factory for special requirements that must be met if the pump is to operate beyond one or more of the limits specified above.

PULLEY INFORMATION

Pulley selection and pump speed are based on a 1725 RPM motor and "B" section belts. When selecting desired GPM, allow for a ±5% tolerance on pumps output due to variations in pulleys, belts and motors among manufacturers.

1. Select GPM required, then select appropriate motor and pump pulley from the same line.
2. The desired pressure is achieved by selecting the correct nozzle size that corresponds with the pump GPM.

HORSEPOWER INFORMATION

Horsepower ratings shown are the power requirements for the pump. Gas engine power outputs must be approximately twice the pump power requirements shown above.

We recommend that a 1.15 service factor be specified when selecting an electric motor as the power source. To compute specific pump horsepower requirements, use the following formula:

$$(GPM \times PSI) / 1450 = HP$$

GP7155HTC HTC PULLEY SELECTION & HORSEPOWER REQUIREMENTS					
RPM	GPM	500 PSI	750 PSI	1000 PSI	1160 PSI
200	18.4	6.3	9.5	12.7	14.7
300	27.7	9.6	14.3	19.1	22.2
400	36.9	12.7	19.1	25.4	29.5
460	42.3	14.6	21.9	29.2	33.8

Exploded View - GP7155HTC

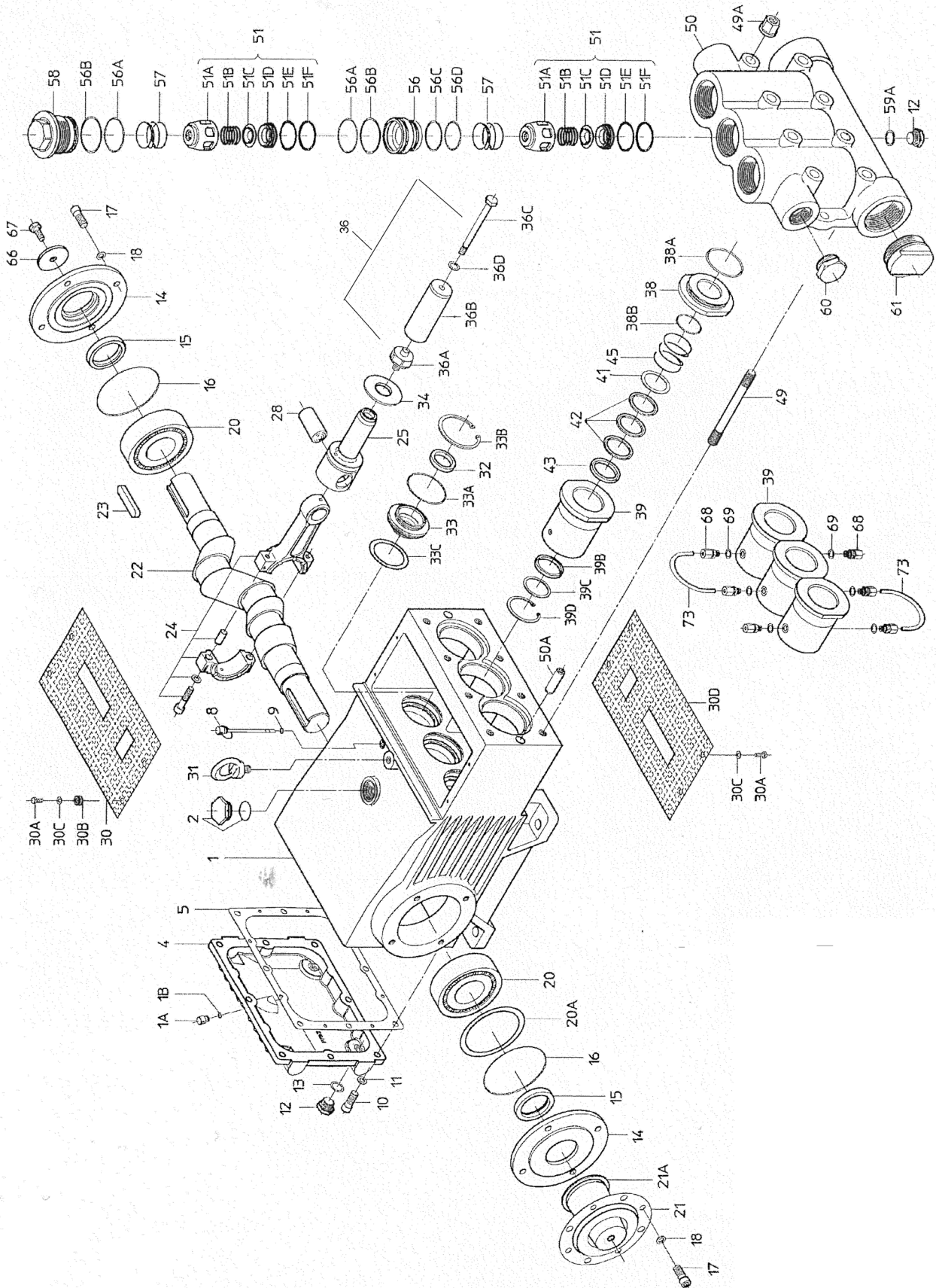

PARTS LIST - GP7155HTC

<u>ITEM</u>	<u>PART</u>	<u>DESCRIPTION</u>	<u>QTY.</u>	<u>ITEM</u>	<u>PART</u>	<u>DESCRIPTION</u>	<u>QTY.</u>
1	07600	Crankcase	1	36B	07666	Plunger Pipe	3
1A	05525	Head for Oil Dipstick	1	36C	07664	Tension Screw	3
1B	01009	O-Ring	1	36D	07665	Copper Ring	3
2	13000	Oil Filler Plug Assy.	1	38	05715	Seal Case	3
4	07601	Crankcase Cover	1	38A	13156-0003	O-Ring for 38	3
5	05757	Gasket, Crankcase Cover	1	38B	07721-0003	O-Ring for 38	3
8	07603	Oil Dip Stick	1	39	05716	Seal Sleeve	3
9	01009	O-Ring, Dip Stick	1	39B	05717	Compact Ring	3
10	22706	Hexagon Screw	8	39C	05718	Support Disc	3
11	06725	Spring Washer	8	39D	05719	Clip Ring	3
12	07109	Drain Plug	3	41	05720	Sleeve Support Ring	3
13	07182	Gasket, Drain Plug	2	42	07711-0030	V-Sleeve	9
14	05644	Bearing Cover	2	43	07712	Pressure Ring	3
15	07608	Radial Shaft Seal	2	45	05721	Pressure Spring	3
16	07184	O-Ring	2	49	13159	Stud Bolt	8
17	05642	Inner Hexagon Screw	8	49A	13160	Hexagon Nut	8
18	05039	Spring Washer	8	50	05758	Valve Casing, Bronze	1
20	07610	Taper Roller Bearing	2	50A	13162	Cylinder Stud	2
20A	07611	Fitting Disc (Shim)	1-5	51	05759	Valve Assembly (51A-51F)	6
21	05645	Holder, Shaft Protector	1	51A	13165	Spring Tension Cap	6
21A	05646	Shaft Protector	1	51B	07732-0100	Valve Spring	6
22	13405	Crankshaft	1	51C	05314	Valve Plate	6
23	07614	Key	1	51D	05136A	Valve Seat	6
24	13182	Connecting Rod Assy.	3	51E	07653-0003	O-Ring	6
25	13183	Crosshead Assy.	3	51F	13166	Support Ring	6
28	13184	Crosshead Pin	3	56	13167	Valve Adaptor	3
30	05713	Tin Lid	1	56A	07658-0003	O-Ring for 56, 58	6
30A	07225-0100	Hexagon Screw	8	56B	07635	Support Ring for 56A, 58A	6
30B	13136	Grommet	4	56C	13166	Support Ring	3
30C	08280	Disc	8	56D	07653-0003	O-Ring	3
30D	05714	Cover Plate	1	57	13173	Tension Spring	6
31	07623	Eye Bolt	1	58	13170	Plug, M64 x 2	3
32	07624	Radial Shaft Seal	3	59A	07661	Copper Ring for 12	1
33	07626	Seal Retainer	3	60	13151	Plug, 1-1/4" BSP	1
33A	07627	O-Ring	3	61	13171	Plug, 2-1/2" BSP	1
33B	07628	Circlip	3	66	13362	Disc For Crankshaft	1
33C	07249	Fitting Disc	3	67	13358	Hexagon Screw	1
34	13137	Oil Scraper	3	68	06588	Screw-In Connector	6
36	07706	Plunger Pipe Assy.(36A-D)	3	69	07204-0100	Steel Ring	6
36A	07667	Plunger Connection	3	73	05722	Pipe Bend, 180°	2
					07662	Valve Tool (Not Shown)	1

REPAIR KITS - GP7155HTC

Plunger Packing Kit - # 09700

<u>Item</u>	<u>Part #</u>	<u>Description</u>	<u>Qty.</u>
38A	13156-0003	O-Ring	3
38B	07721-0003	O-Ring	3
39B	05717	Compact Ring	3
42	07711-0030	V-Sleeve	9

Valve Assembly Kit - # 09604A-0003

<u>Item</u>	<u>Part #</u>	<u>Description</u>	<u>Qty.</u>
51B	07732-0100	Valve Spring	6
51C	05314	Valve Plate	6
51D	05136A	Valve Seat	6
51E	07653-0003	O-Ring	6
51F	13166	Support Ring	6
56A	07658-0003	O-Ring	6
56B	07635	Support Ring	6
56C	13166	Support Ring	3
56D	07653-0003	O-Ring	3

Oil Seal Kit - # 09221

<u>Item</u>	<u>Part #</u>	<u>Description</u>	<u>Qty.</u>
32	07624	Radial Shaft Seal	3
33A	07627	O-Ring	3

GP7155HTC TORQUE SPECIFICATIONS

<u>Position</u>	<u>Item#</u>	<u>Description</u>	<u>Torque Amount</u>
24	13182	Connecting Rod Assembly	30 ft.-lbs. (40 NM)
36A	07667	Plunger Connection	33 ft.-lbs. (45 NM)
36C	07664	Tension Screw	30ft.-lbs. (40 NM)
49A	13160	Hexagon Nut	103 ft.-lbs. (140 NM)
58	13170	Plug	107 ft-lbs (145 NM)

Preventative Maintenance Check List & Recommended Spare Parts List						
Check	Daily	Weekly	50 hrs	Every 500 hrs	Every 1500 hrs	Every 3000 hrs
Oil Level/Quality	X					
Oil Leaks	X					
Water Leaks	X					
Belts, Pulley		X				
Plumbing		X				
Recommended Spare Parts						
Oil Change p/n 01154			X	X		
Plunger Packing Kit (1 kit/pump)					X	
Oil Seal Kit (1 kit/pump)					X	
Valve Kit (1 kit/pump)						X

GP7155HTC Repair Instructions

TO CHECK VALVES

Loosen plugs (58), take out tension spring (57) and then remove the complete valve assembly (51) with either a valve tool or an M16 hexagon screw. To remove the valve adapter (56) and tension spring (57), use a pullout tool size 5. The o-ring (51H) can be removed with a bent piece of wire. To disassemble valve assembly, screw out the valve seat (51E) from the spring tension guide (51A). Check the sealing surfaces and replace worn parts. Check O-rings and support rings. Tighten plugs (58) to 107 ft.-lbs. (145 NM).

TO CHECK SEALS AND PLUNGER PIPE

Loosen nuts (49A) and remove pump head (50). Separate the plunger connection (36A) from the crosshead (25) by means of two open-end wrenches (size 22mm and 27mm). Pull seal sleeves (39) out of their fittings in the crankcase (1). Take the seal case (38) out of the seal sleeve (39). Examine the plunger parts (36A-36D), seals (42 & 39A) and O-rings. When replacing the plunger pipe (36B), tighten tension screws (36C) to 30 ft. lbs. (40 NM). Replace worn parts; grease seals with Silicone before installing.

CAUTION: Don't loosen the 3 plunger connections (36A) before the valve casing has been removed otherwise the tension screw (36C) could hit against the valve adapter (56) when the pump is being turned. Seal life can be increased if the pre-tensioning allows for a little leakage. This assists lubrication and keeps the seals cool. It is therefore not necessary to replace seals before the leakage becomes too heavy and causes output and operating pressure to drop.

MOUNTING VALVE CASING

Check O-rings on the seal case (38). Clean surfaces of seal sleeves in gear box and sealing surfaces of valve casing (50). Push the valve casing carefully on the O-rings of the seal case and centering studs (50A). Tighten nuts (49A) to 103 ft. lbs. (140 NM).

TO DISASSEMBLE GEAR

Take out plunger (36) and seal sleeves (39) as described above. Drain the oil. After removing the circlip ring (33B), lever out seal retainer (33) with a screw driver. Check seals (32 & 33A) and surfaces of crosshead (25). Remove the crankcase cover (4). Loosen inner hexagon screws on the connecting rods (24).

Note: Connecting rods are marked for identification. Do not twist connecting rod halves. Each connecting rod is to be reinstalled in the same position (and orientation) on the crankshaft journals.

Push the connecting rod halves as far into the crosshead guide as possible. Check the surfaces of connecting rod and crankshaft (22). Take out the bearing cover (14) to one side and push out crankshaft taking particular care that the connecting rod doesn't bend.

Re-assemble in reverse order. Regulate axial bearing clearance to a minimum of 0.1mm and a maximum of 0.15mm by means of fitting discs (20A). The crankshaft should turn easily and with little clearance. Tighten screws (24) to 30 ft.-lbs. (40 NM).

Important! The connecting rod has to be able to slightly move sidewise at the crankshaft journal.

Important! Seal (32) must always be installed so that the seal-lip on the inside diameter faces the oil. Possible axial float of the seal retainer (33) should be compensated with the shims (33C).

GP7155HTC Dimensions - mm

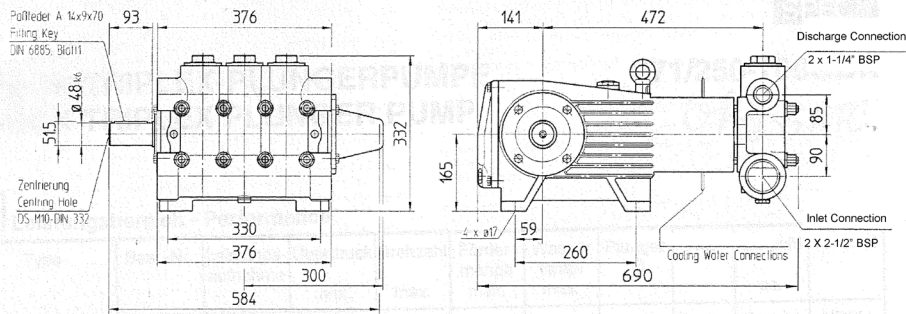

GIANT INDUSTRIES LIMITED WARRANTY

Giant Industries, Inc. pumps and accessories are warranted by the manufacturer to be free from defects in workmanship and material as follows:

1. For portable pressure washers and car wash applications, the discharge manifolds will never fail, period. If they ever fail, we will replace them free of charge. Our other pump parts, used in portable pressure washers and in car wash applications, are warranted for five years from the date of shipment for all pumps used in NON-SALINE, clean water applications.
2. One (1) year from the date of shipment for all other Giant industrial and consumer pumps.
3. Six (6) months from the date of shipment for all rebuilt pumps.
4. Ninety (90) days from the date of shipment for all Giant accessories.

This warranty is limited to repair or replacement of pumps and accessories of which the manufacturer's evaluation shows were defective at the time of shipment by the manufacturer. The following items are NOT covered or will void the warranty:

1. Defects caused by negligence or fault of the buyer or third party.
2. Normal wear and tear to standard wear parts.
3. Use of repair parts other than those manufactured or authorized by Giant.
4. Improper use of the product as a component part.
5. Changes or modifications made by the customer or third party.
6. The operation of pumps and or accessories exceeding the specifications set forth in the Operations Manuals provided by Giant Industries, Inc.

Liability under this warranty is on all non-wear parts and limited to the replacement or repair of those products returned freight prepaid to Giant Industries which are deemed to be defective due to workmanship or failure of material. A Returned Goods Authorization (R.G.A.) number and completed warranty evaluation form is required prior to the return to Giant Industries of all products under warranty consideration. Call (419)-531-4600 or fax (419)-531-6836 to obtain an R.G.A. number.

Repair or replacement of defective products as provided is the sole and exclusive remedy provided hereunder and the MANUFACTURER SHALL NOT BE LIABLE FOR FURTHER LOSS, DAMAGES, OR EXPENSES, INCLUDING INCIDENTAL AND CONSEQUENTIAL DAMAGES DIRECTLY OR INDIRECTLY ARISING FROM THE SALE OR USE OF THIS PRODUCT.

THE LIMITED WARRANTY SET FORTH HEREIN IS IN LIEU OF ALL OTHER WARRANTIES OR REPRESENTATION, EXPRESS OR IMPLIED, INCLUDING WITHOUT LIMITATION ANY WARRANTIES OR MERCHANTABILITY OR FITNESS FOR A PARTICULAR PURPOSE AND ALL SUCH WARRANTIES ARE HEREBY DISCLAIMED AND EXCLUDED BY THE MANUFACTURER.

GIANT INDUSTRIES, INC.

900 N. Westwood Ave. P.O. Box 3187
Toledo, Ohio 43607
Phone; (419) 531-4600 FAX (419) 531-6836
© Copyright 2011 Giant Industries, Inc.
www.giantpumps.com



03/11 GP7155HTC.indd