

Model P470H

Triplex Ceramic
Plunger Pump
Operating Instructions/
Repair and Service Manual

Hydraulic Drive Pump

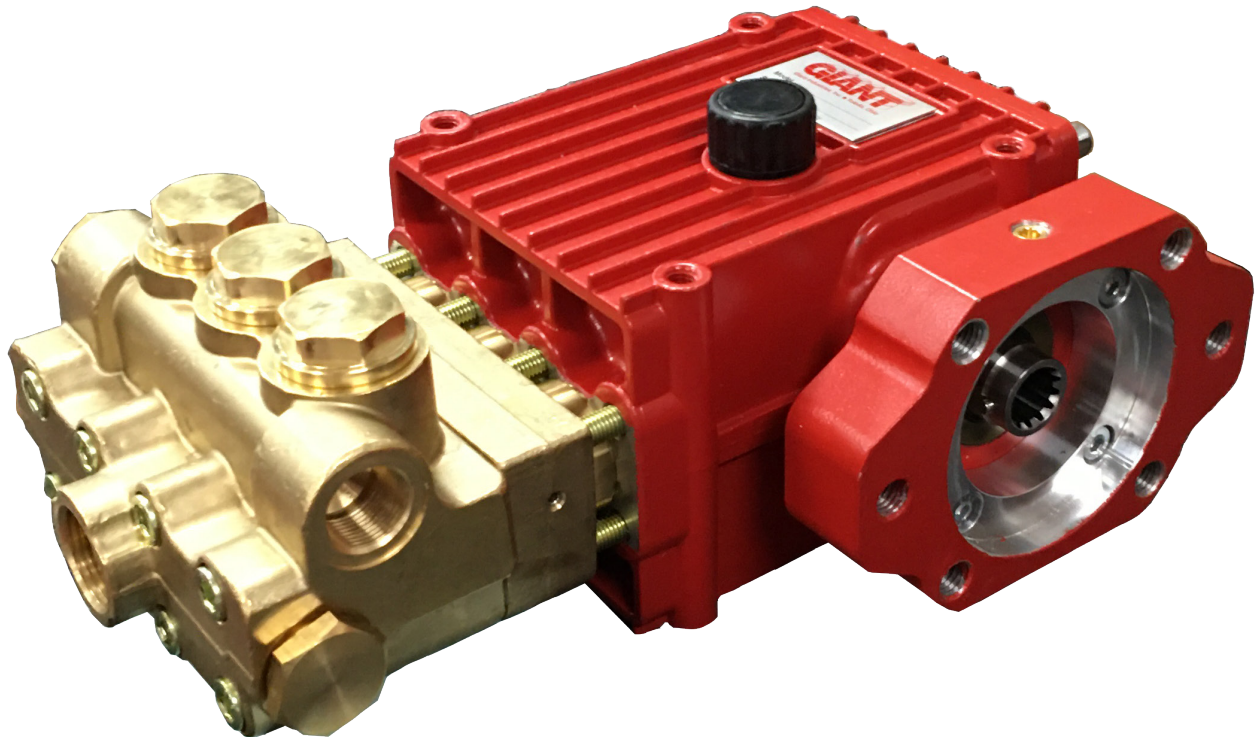

GIANT
Performance Under Pressure

Updated 04/23

Contents:

Installation Instructions:	page 2
Pump Specifications:	page 3
Exploded View:	page 4
Parts List / Kits:	page 5
Torque Specifications	page 5
Repair Instructions:	pages 6-7
Dimensions:	back page
Warranty Information:	back page

INSTALLATION INSTRUCTIONS

Required NPSH refers to water (specific weight 1kg/dm^3 , viscosity 1°E) and maximum permissible pump revolutions.

Operation and Maintenance

Check oil level prior to starting and ensure trouble-free water supply.

Important! If there is a danger of frost, the water in the pump and in the pump fittings (particularly the unloader valve) must be emptied. The second discharge port can be used and the pump run "dry" for 1-2 minutes for this purpose.

Oil: Use only 27.1 fluid ounces (0.8 liters) of ISO VG 220 GL4 (e.g. Aral Degol BG220) or SAE 90 GL4 gear oil (Giant p/n 01154).

Initial oil change after 50 operating hours and then every 500 hours, after 1 year if used less.

Caution: When operating in damp places or with high temperature fluctuations, oil must be changed immediately [should condensate (frothy oil) occur in the gear box].

NPSH values must be observed.

Maximum input pressure 145 PSI (10 bar), maximum suction head -4.35 PSI (-0.3 bar). Make sure that suction pulsation is sufficiently dampened - water column resonance must be avoided.

Important! If the pump is not used for a long period of time, it is possible the seals (23) could become hard or brittle thus causing the pump to leak when put into operation.

If this is the case, we recommend these seals be replaced every 4 years.

Safety Rules

A safety valve is to be installed in accordance with the guidelines for liquid spraying units so that the admissible operating pressure cannot be exceeded by more than 10%. Pump operation without a safety valve as well as any excess in temperature or speed limits automatically voids the warranty.

When the pump is in operation, the drive shaft end and the coupling must be enclosed by a protective cover or a coupling bell.

Pressure in the discharge line and pump must be at zero before any maintenance to the pump takes place. Close suction line. Disconnect fuses to ensure that the driving motor does not get switched on accidentally.

Make sure that all parts on the pressure side of the unit are vented before starting the pump. In order to prevent air, or an air-water mixture being absorbed and to prevent cavitation occurring, the pump NPSHR suction head and water temperature must be respected.

Cavitation and/or compression of gases lead to uncontrollable pressure kicks which can ruin pump and unit parts and also be dangerous to the operator or anyone standing nearby.

Giant plunger pumps are suitable for pumping clean water and other non-aggressive or non-abrasive media with a specific weight similar to water.

Before pumping other liquids - especially inflammable, explosive and toxic media - the pump manufacturer must be consulted with regard to the resistance of the pump material. It is the responsibility of the equipment manufacture and/or operator to ensure that all pertinent safety regulations are adhered to.

Specifications Model P470H

	U.S.	METRIC
Volume	Up to 18.4 GPM.....	69.7 L/min
Discharge Pressure.....	Up to 2030 PSI.....	140 Bar
Max. Inlet Pressure	-4.35 to 145 PSI	-0.3 to 10 bar
Power Required	25.7 BHP	19.2 kW
Maximum Crankshaft Rotation Speed	Up to 1450 RPM	
Stroke.....	0.94"	24mm
Crankcase Oil Capacity.....	27.1 fl.oz.....	0.8 Liters
Temperature of Pumped Fluids	Up to 160 °F	70 °C
Plunger Diameter	1.18"	30mm
Inlet Ports	(1) x 1" BSP* & (2) x 3/4" BSP	
Discharge Ports.....	(2) 3/4" BSP	
Crankshaft Bore	SAE 2B or SAE 4B 13T 16/32 Spline**	
Shaft Rotation	Towards fluid end	
Weight.....	39.7 lbs.....	18 kg
NPSHR.....	32.8 feet of head	10.0 meters of head

* Recommended for inlet connection.

** J498b 30° Class 5

Consult the factory for special requirements that must be met if the pump is to operate beyond one or more of the limits specified above.

P470 HORSEPOWER REQUIREMENTS						
RPM	GPM	500 PSI	750 PSI	1000 PSI	1500 PSI	2030 PSI
1000	12.7	4.4	6.6	8.8	13.1	17.8
1100	14.0	4.8	7.2	9.7	14.5	19.6
1200	15.2	5.2	7.9	10.5	15.7	21.3
1300	16.5	5.7	8.5	11.4	17.1	23.1
1450	18.4	6.3	9.5	12.7	19.0	25.8

NOTE:

In order to drive the pump from the side opposite the present shaft extension, simply remove the valve casing from the crankcase and rotate the pumps 180 degrees to the desired position. Be certain to rotate the seal case (item #20) as well, so that the weep holes are down at the six o'clock position. Exchange the oil fill and the oil drain plugs, also. Refer to the repair instructions as necessary for the proper assembly sequence.

Horsepower Ratings:

Horsepower ratings shown are the power requirements for the pump. Gas engine power outputs must be approximately twice the pump power requirements shown above. We recommend that a 1.15 service factor be specified when selecting an electric motor as the power source. To compute specific pump horsepower requirements, use the following formula: (GPM X PSI) / 1450 = HP

For the Application of a Hydraulic Motor:

To Determine the Torque of a Hydraulic Motor -- (GPM x PSI x 36.77) / RPM = Torque (in-lbs)

Exploded View - P470H

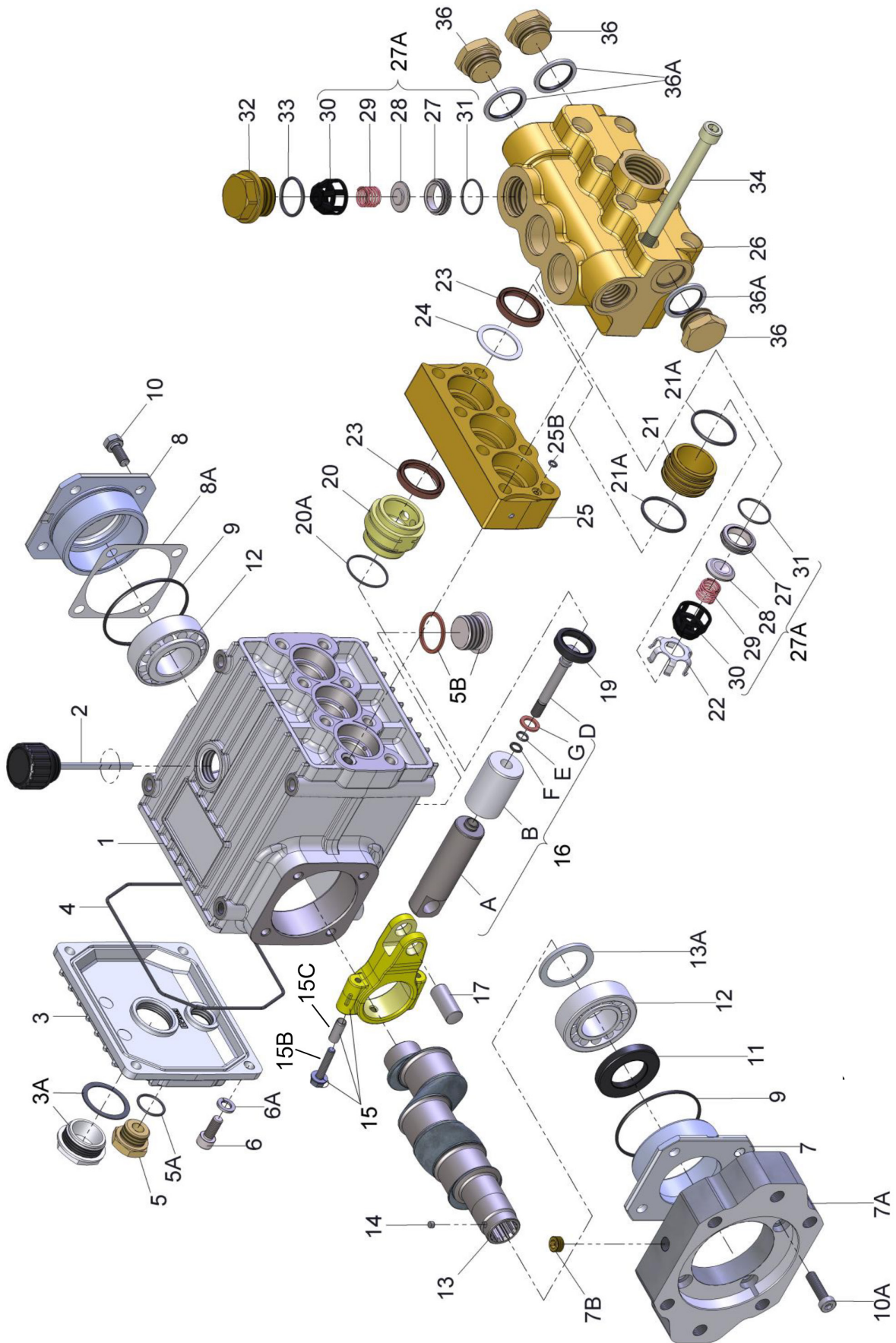

P470H PARTS LIST

<u>ITEM</u>	<u>PART</u>	<u>DESCRIPTION</u>	<u>QTY.</u>	<u>ITEM</u>	<u>PART</u>	<u>DESCRIPTION</u>	<u>QTY.</u>
1	08377	Crankcase	1	16F	07203	Support Ring	3
2	08378	Oil Fill Plug with Gasket	1	16G	07258	Copper Gasket	3
3	06479	Crankcase Cover	1	17	06790	Crosshead Pin	3
3A	07186	Oil Sight Glass w/Gasket	1	19	08366	Oil Seal	3
4	08380	O-Ring	1	20	06928	Seal Adapter	3
5	07109	Oil Drain Plug	1	20A	08059	O-Ring	3
5A	06015	O-Ring	1	21	06929	Seal Case	3
5B	08092	Plug with Gasket	1	21A	07150	O-Ring	6
6	01010	Screw	4	22	06930	Valve Holder	3
6A	01011-0400	Spring Washer	4	23	06931*	Grooved Seal	6
7	04739	Bearing Cover, Open	1	24	06932	Support Ring	3
7A	03266	Motor Flange	1	25	06933	Intermediate Casing	1
7B	03297	Plug, M12 x 1	1	25B	02009	O-Ring	2
8	05291	Bearing Cover, Closed	1	26	06935	Valve Casing	1
8A	05292	Shim, 0.1 mm	1-3	27A	04365	Valve Assembly	6
9	01016	O-Ring	2	27	06937	Valve Seat	6
10	07114	Hexagon Socket Screw	4	28	06938	Valve Plate	6
10A	07774	Hexagon Socket Screw	4	29	06959	Valve Spring	6
11	07459	Radial Shaft Seal	1	30	06939	Valve Spring Retainer	6
12	05350	Bearing	2	31	07212	O-Ring	6
13	03268	Crankshaft	1	32	08373	Plug	3
13A	04742	Spacer Ring	1	33	07214	O-Ring	3
14	03269	Magnet	1	34	06494	Cap Screw	8
15	08390	Connecting Rod Assembly	3	36	07703	Plug, 3/4" BSP	3
15B	05349	Connecting Rod Screw	3	36A	04529	Copper Ring	3
15C	05348	Adapter Sleeve	3				
16	05933	Plunger Assembly	3				
16A	05352	Plunger Base	3				
16B	06927	Plunger Pipe	3				
16D	08399	Tension Screw	3				
16E	07023	O-Ring	3				

***Important!** If the pump is not used for a long period of time, it is possible the seals (23) could become hard or brittle thus causing the pump to leak when put into operation. If this is the case we recommend these seals be replaced every 4 years.

P470H REPAIR KITS

Plunger Packing Kit, #09565

<u>Item</u>	<u>Part #</u>	<u>Description</u>	<u>Qty.</u>
20A	08059	O-Ring	3
21A	07150	O-Ring	6
23	06931	Grooved Seal	6
24	06932	Support Ring	3
25B	02009	O-Ring	2

Valve Assembly Kit, #09566

<u>Item</u>	<u>Part #</u>	<u>Description</u>	<u>Qty.</u>
27A	04365	Valve Assembly	6
31	07212	O-Ring	6
33	07214	O-Ring	3

Oil Seal Kit, #09306

<u>Item</u>	<u>Part #</u>	<u>Description</u>	<u>Qty.</u>
19	08366	Oil Seal	3

P470H Torque Specifications

<u>Item</u>	<u>Part #</u>	<u>Description</u>	<u>Lubrication Info</u>	<u>Torque Amount</u>
3A	07186	Oil Sight Glass/Gasket	Loctite 5910	106 in.-lbs. (12 Nm)
5	07109	Plug		59 ft.-lbs. (80 Nm)
5B	08092	Plug w/Gasket		59 ft.-lbs. (80 Nm)
6	01010	Screw		110 in.-lbs. (12.5 Nm)
10	07114	Screw with Washer		132 in.-lbs. (15 Nm)
10A	07774	Hexagon Socket Screw		132 in.-lbs. (15 Nm)
15	08390	Connecting Rod Screw		97 in.-lbs. (11 Nm)
16D	08399	Tension Screw	Loctite 243	21 ft.-lbs. (28 Nm)
32	08373	Plug	Loctite 243	125 ft.-lbs. (170 Nm)
34	06494	Cap Screw	Lightly Oil Threads	30 ft.-lbs. (40 Nm)

REPAIR INSTRUCTIONS - P470H PUMPS

To Check Valves

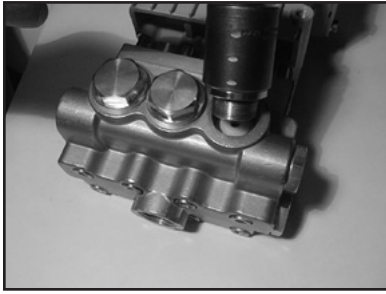

1. Remove plugs (32) with socket wrench.

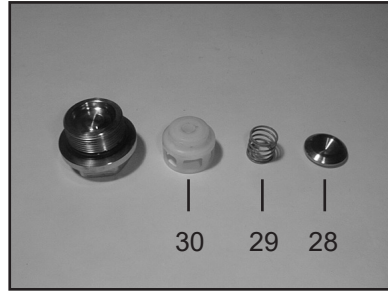

2. Remove the exposed spring tension cap (30) from valve seat by pushing it sideways with a screwdriver. Remove spring tension cap (30), valve spring (29), and valve plate (28).

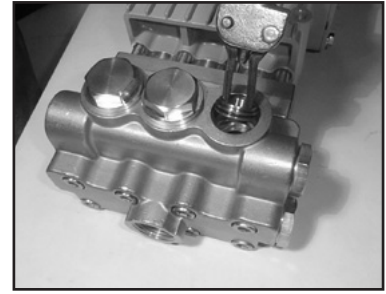

3. Pull out valve seat (27) and O-ring (31) with a valve puller. Check O-ring for wear.

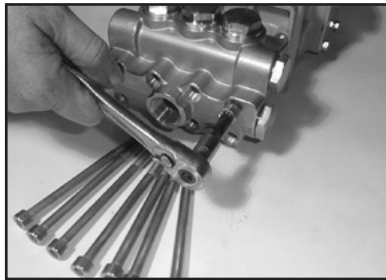

4. Remove hexagon socket screws (34) and remove valve casing (26) by pulling them frontwise over the plungers (16).

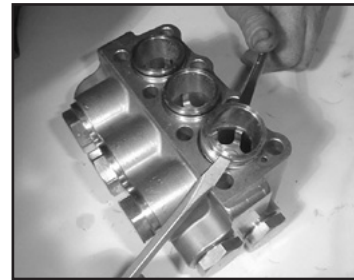

5. Using two screwdrivers, remove seal case (21) out of the valve casing (26) or intermediate casing (25).

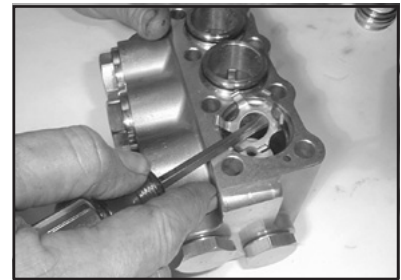

6. The exposed suction valve parts are to be removed the same way as the discharge valves as described above. Check valve components for wear and damage. Check O-rings (21A, 31, 33). Replace worn parts. Reassemble in same order. Coat new o-rings with oil before installation. Coat O-rings (25B) with silicon grease and place them in their recesses. Insert seal cases (21) into valve casing (26) before mounting the whole unit. Slide valve casing (26) over plungers. Tighten hexagon socket screws (34) crosswise and evenly at 36 ft.-lbs. Tighten plugs (32) at 125 ft.-lbs. (170 Nm).

To Check To Check Seals and Plunger Pipe

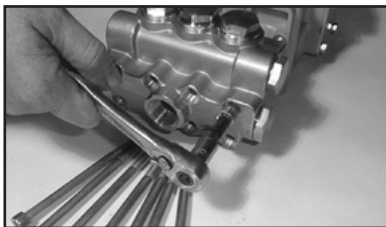

7. Remove hexagon socket screws (34) and remove valve casing (26) by pulling them frontwise over the plungers (16).



8. Using two screwdrivers, gently pry seal cases (21) out of the valve casing (26) or intermediate casing (25). Press grooved rings (23) and support rings (24) out of intermediate casing (25) using a screwdriver. Check O-rings (21A/25B). Examine seals (23). Replace worn seals.

Important: When extracting the valve holders (22), make sure not to scratch the outer bore diameter as this is a sealing.

REPAIR INSTRUCTIONS - P470H PUMPS

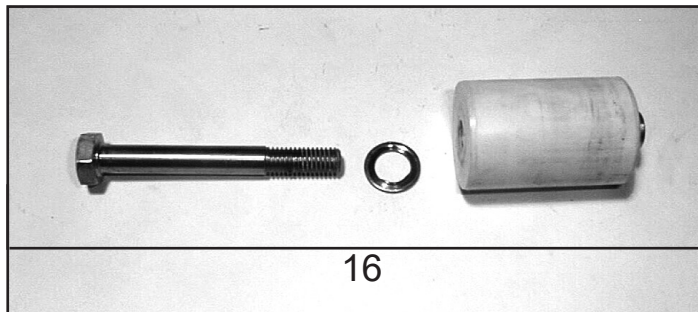

9. Check plunger surfaces (16). Damaged surfaces lead to accelerated seal wear. Deposits of all kinds must be removed from the plungers.

Important: Plunger surfaces are not to be damaged. If there are lime deposits in the pump, care must be taken that the weep-return bore in parts (25) and (26) ensure trouble-free weep-return.

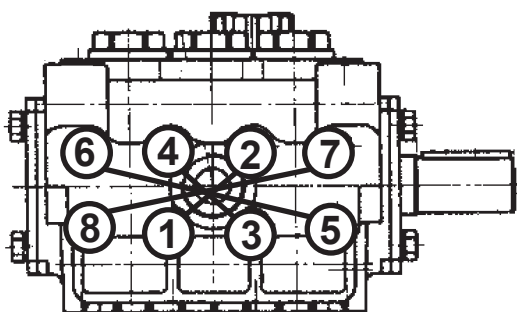

Gear and Plunger

If oil leaks where the plungers (16) protrude out of the gear, gear seals (19) and plungers must be examined and replaced if necessary.

- a) **Gear Seal:** Remove oil plug (5) and drain oil. Remove valve casing (26) together with seal casing (25) as described above. Dismantle plunger pipe (16B). Pry gear seal adaptor (20) out of the crankcase using a screwdriver; take out gear seal (19) and replace it.
- b) **Plungers:** Remove oil plug (5) and drain oil; remove crankcase cover (3). Remove valve casing (26), seal casing (25), gear seal adaptors (20) and plunger pipes (16B) as described above. Remove screws on conn-rods (15). Be careful not to mix up the connecting rod halves. Push connecting rod shaft as far as possible into the crosshead guide. Take off screws (10) and pry out bearing covers (7 & 8) with the help of a screwdriver. Take out crankshaft carefully threading it past the conrods (15), making sure not to bend the connecting rods. Remove and dismantle connecting rods and plungers (16). Replace worn parts. Reassemble and tighten tension screws (16D) at 248 in.-lbs. (28 Nm). When reinstalling, first insert connecting rods together with plungers. Thread in crankshaft. Then push bearing covers (7 & 8) onto the crankshaft ends. Screw on bearing covers with screws (10). Mount connecting rod halves and tighten screws (15) at 22 ft.-lbs. Mount crankcase cover (3) together with O-ring (4). Replace seal adaptors (20), seal casing (25) and valve casing (26). Replace eight (8) hexagon screws (34) and tighten to 30 ft.-lbs. (40 Nm).

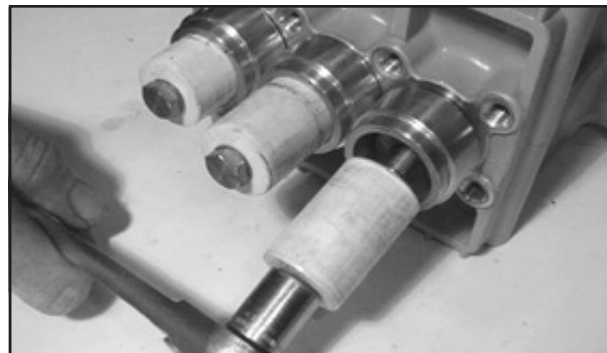

10. If the plunger pipe (16B) is worn, remove tension screw (16D) and remove together with plunger pipe. Check and clean plunger (16A) surfaces and mount new plunger pipe. Cover thread of tension screw (16D) with a thin film of Loctite and tighten carefully at 248 in.-lbs. (28 Nm).

Important: Glue must never come between the plunger pipe (16B) and the centring sleeve (16C). The plunger pipe is not to be strained by eccentric tightening of the tension screw or through damage to the front surface as this can lead to breakage.

11. When reassembling, tighten inner hexagon screw (34) at 30 ft.-lbs. (40 Nm) in a crossing pattern (as shown on left).

MODEL P470H DIMENSIONS - INCHES (mm)

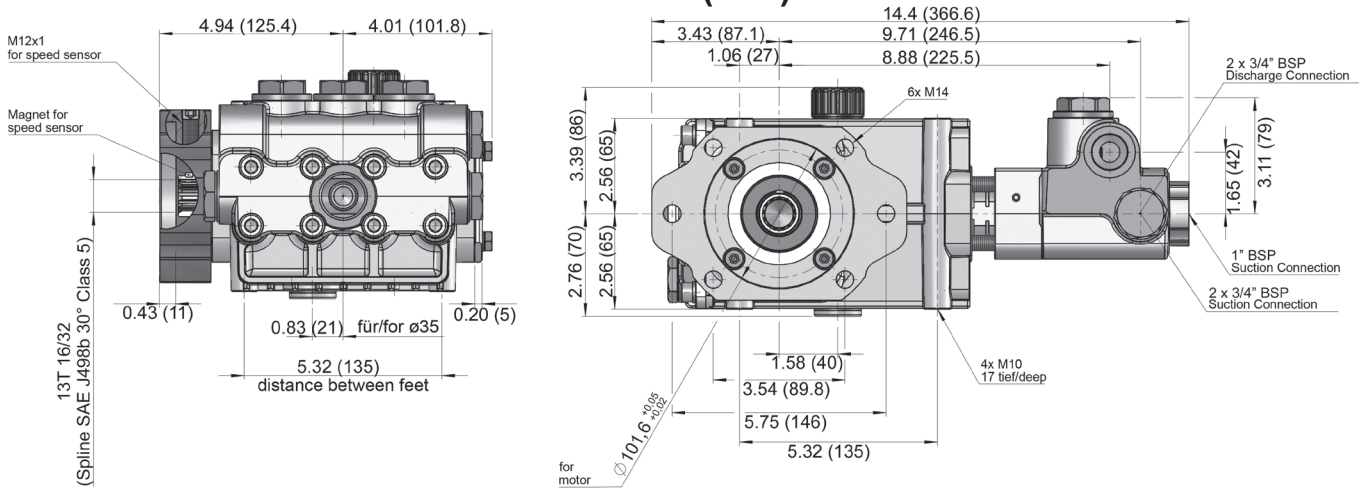

GIANT INDUSTRIES LIMITED WARRANTY

Giant Industries, Inc. pumps and accessories are warranted by the manufacturer to be free from defects in workmanship and material as follows:

- Five (5) years from the date of shipment for all pumps used in portable pressure washers with NON-SALINE, clean water applications.
- Two (2) years from the date of shipment for Giant pumps used in car wash applications.
- One (1) year from the date of shipment for all other Giant industrial and consumer pumps.
- Six (6) months from the date of shipment for all rebuilt pumps
- Ninety (90) days from the date of shipment for all Giant accessories.

This warranty is limited to repair or replacement of pumps and accessories of which the manufacturer's evaluation shows were defective at the time of shipment by the manufacturer. The following items are NOT covered or will void the warranty:

- Defects caused by negligence or fault of the buyer or third party.
- Normal wear and tear to standard wear parts.
- Use of repair parts other than those manufactured or authorized by Giant.
- Improper use of the product as a component part.
- Changes or modifications made by the customer or third party.
- The operation of pumps and or accessories exceeding the specifications set forth in the Operations Manuals provided by Giant Industries, Inc.

Liability under this warranty is on all non-wear parts and limited to the replacement or repair of those products returned freight prepaid to Giant Industries which are deemed to be defective due to workmanship or failure of material. A Returned Goods Authorization (R.G.A.) number and completed warranty evaluation form is required prior to the return to Giant Industries of all products under warranty consideration. Call (419)-531-4600 or fax (419)-531-6836 to obtain an R.G.A. number.

Repair or replacement of defective products as provided is the sole and exclusive remedy provided hereunder and the MANUFACTURER SHALL NOT BE LIABLE FOR FURTHER LOSS, DAMAGES, OR EXPENSES, INCLUDING INCIDENTAL AND CONSEQUENTIAL DAMAGES DIRECTLY OR INDIRECTLY ARISING FROM THE SALE OR USE OF THIS PRODUCT.

THE LIMITED WARRANTY SET FORTH HEREIN IS IN LIEU OF ALL OTHER WARRANTIES OR REPRESENTATION, EXPRESS OR IMPLIED, INCLUDING WITHOUT LIMITATION ANY WARRANTIES OR MERCHANTABILITY OR FITNESS FOR A PARTICULAR PURPOSE AND ALL SUCH WARRANTIES ARE HEREBY DISCLAIMED AND EXCLUDED BY THE MANUFACTURER.



WARNING: This product might contain a chemical known to the State of California to cause cancer, and birth defects or other reproductive harm.
For more information go to www.P65Warnings.ca.gov

GIANT
Performance Under Pressure

GIANT INDUSTRIES, INC., 900 N. Westwood Ave., Toledo, Ohio 43607
PHONE (419) 531-4600, FAX (419) 531-6836, www.giantpumps.com
© Copyright 2023 Giant Industries, Inc.