

Models

GP8055-Brine

GP8060-Brine

GP8065-Brine

Triplex Ceramic
Plunger Pump
Models Manual

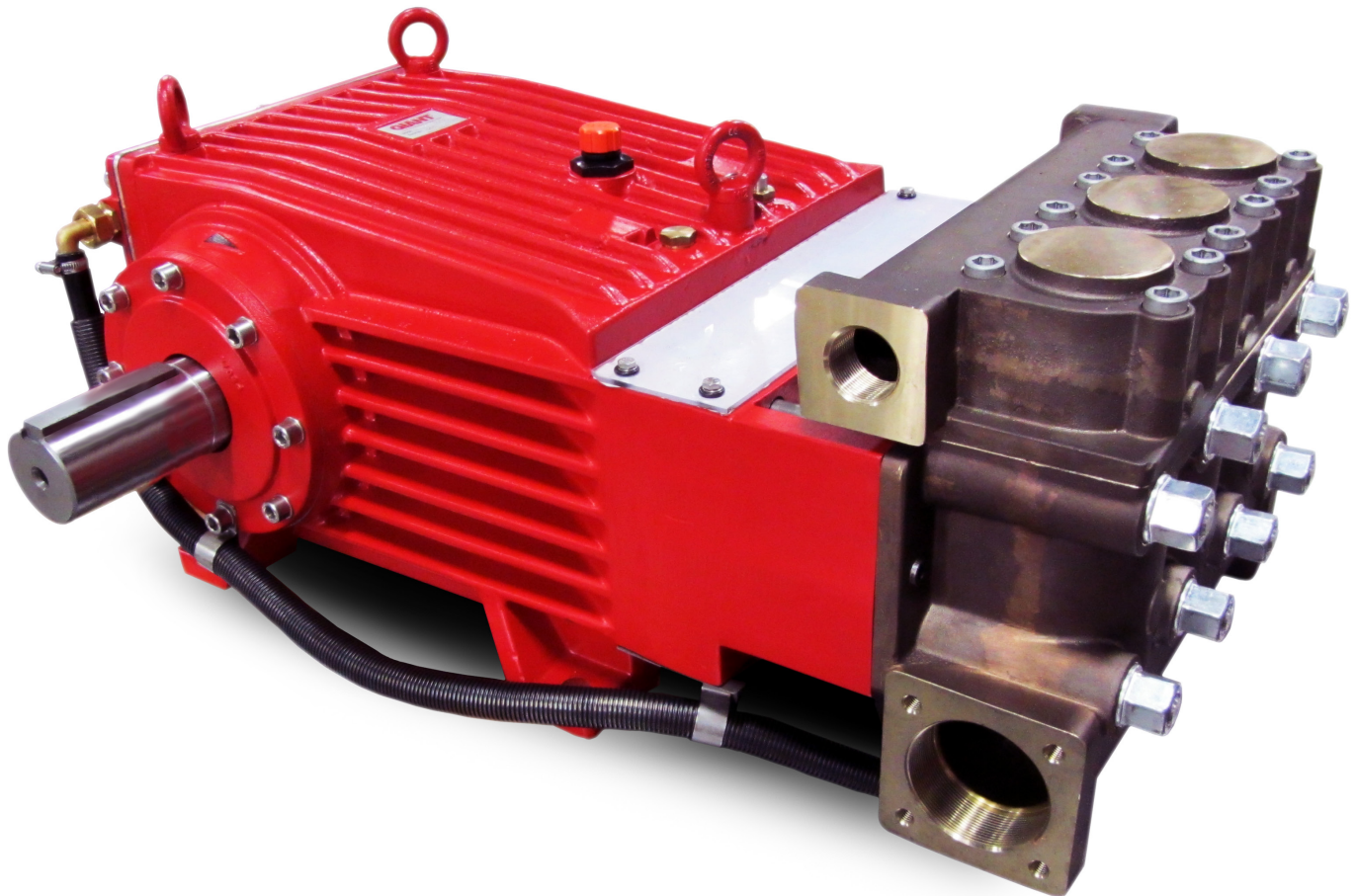

GIANT
Performance Under Pressure

Contents:	
Installation Instructions:	page 2
Pump Specifications:	page 3-5
Exploded View/Parts List:	pages 6-7
Repair Kits/Tool List:	page 8
Torque Specifications:	page 8
Troubleshooting Chart:	page 8
Repair Instructions:	pages 9-11
Dimensions:	back page
Warranty Information	back page

Updated 02/23

INSTALLATION INSTRUCTIONS

The stated figures are for maximum pressure and maximum speed (RPM) and apply for interval operation with cold water.

Required NPSH refers to water (specific weight 1kg/dm³, viscosity 1°E) at maximum permissible pump revolutions.

Fluid medium: Clean water filter with 50µm.

Operation and Maintenance

Check oil level prior to starting and ensure trouble-free water supply.

Important! If there is a **danger of frost**, the water in the pump and in the pump fittings (particularly the unloader valve) must be emptied. The second discharge port can also be used and the pump run “dry” for 1-2 minutes for this purpose.

Oil: Use only 3.3 Gallons (12.5 liters) of ISO VG 220 GL4 (e.g. Aral Degol BG220) or SAE 90 GL4 gear oil (Giant p/n 01154). Initial change after 50 operating hours and then every 1000 operating hours after one year at the latest.

Important! When operating in damp places or with high temperature fluctuations, oil must be changed immediately should condensate (frothy oil) occur in the gear box.

NPSH values must be observed.

Cooling the Gear Oil

Important! The water input pressure must not exceed 2 bar when using the integrated system for cooling the gear oil (standard version).

If a separate cooling circuit (maximum 29 PSI [2 bar]) is installed, it is then possible to have an input pressure of up to maximum 145 PSI (10 bar) on the suction side.

Make sure that suction pulsation is sufficiently dampened - water column resonance must be avoided.

Important! The pumps can be run without gear oil cooling in continuous operation **up to** a power rating of **107 hp (80 kW)** or with major intermittent operation).

If operation power **exceeds 107 hp (80 kW)** or if continuous operation is the case, the pump must be run with the integrated oil cooling system. The maximum temperature of the water being pumped and which is also fed through the cooling system must not exceed 86 °F (30°C). The amount which is fed into the cooling system depends on the pump speed and is approximately 1.85 GPM (7.0 L/min) at 580 RPM. The cooling water is sucked in by one of the pumping chambers and pumped away.

Specifications

Model GP8055-Brine

	U.S.	(Metric)
Volume.....	Up to 75.3 GPM	(285 LPM)
Discharge Pressure	Up to 3000 PSI	(200 bar)
Power Consumption	145 BHP	108 kW
Speed	Up to 580 RPM	580 RPM
Inlet Pressure.....	Up to 29 PSI	(2.0 bar)
Plunger Diameter.....	2.17".....	55mm
Plunger Stroke	2.83".....	72mm
Crankshaft Diameter.....	2.76".....	70mm
Key Width	0.55".....	14mm
Crankshaft Mounting.....	Either side	
Shaft Rotation	Top of pulley towards manifold	
Temperature of Pumped Fluids.....	Up to 86° F*	(30° C)*
Inlet Ports.....	(2) 3" BSP	
Discharge Ports	(2) 1-1/4" BSP	
Weight.....	767 lbs.	(348kg)
Crankcase Oil Capacity	3.3 Gal.	(12.5 liters)
Fluid End Material.....	Nickle Aluminum Bronze	
NPSHR	23.0 ft-head.....	7.0 mWs

*Higher water temperatures possible with separate crankcase cooling system; the manufacturer is to be contacted in this case.

Consult the factory for special requirements that must be met if the pump is to operate beyond one or more of the limits specified above.

GP8055 HORSEPOWER REQUIREMENTS					
RPM	GPM	500 PSI	1000 PSI	2000 PSI	3000 PSI
300	39	13.9	27.9	55.7	83.6
400	52	18.6	37.1	74.3	111.4
500	65	23.2	46.4	92.9	139.3
580	75.5	27.0	53.9	107.9	161.8

HORSEPOWER RATINGS:

The rating shown are the power requirements for the pump. Gas engine power outputs must be approximately twice the pump power requirements shown above.

We recommend a 1.15 service factor be specified when selecting an electric motor as the power source. To compute specific pump horsepower requirements, use the following formula:

$$\frac{\text{GPM} \times \text{PSI}}{1450} = \text{HP}$$

SPECIAL NOTE:
 The theoretical gallons per revolution (gal/rev) is 0.130. To find specific outputs at various RPM, use the formula:

$$\text{GPM} = 0.130 \times \text{RPM}$$

Specifications

Model GP8060-Brine

	U.S.	(Metric)
Volume.....	Up to 89.0 GPM	(340 LPM)
Discharge Pressure	Up to 2465 PSI	(170 bar)
Power Consumption	142 BHP	106 kW
Speed	Up to 580 RPM	580 RPM
Inlet Pressure.....	Up to 29 PSI	(2.0 bar)
Plunger Diameter.....	2.36".....	60mm
Plunger Stroke.....	2.83".....	72mm
Crankshaft Diameter.....	2.76".....	70mm
Key Width	0.55".....	14mm
Crankshaft Mounting.....	Either side	
Shaft Rotation	Top of pulley towards manifold	
Temperature of Pumped Fluids.....	Up to 86° F*	(30° C)*
Inlet Ports.....	(2) 3" BSPP	
Discharge Ports	(2) 1-1/4" BSPP	
Weight.....	767 lbs.	(348kg)
Crankcase Oil Capacity	3.3 Gal.	(12.5 liters)
Fluid End Material.....	Nickle Aluminum Bronze	
NPSHR	26.2 ft-head.....	8.0 mWs

*Higher water temperatures possible with separate crankcase cooling system; the manufacturer is to be contacted in this case.

Consult the factory for special requirements that must be met if the pump is to operate beyond one or more of the limits specified above.

GP8060 HORSEPOWER REQUIREMENTS					
RPM	GPM	500 PSI	1000 PSI	2000 PSI	2500 PSI
300	47	16.8	33.6	67.1	83.9
400	62	22.1	44.3	88.6	110.7
500	78	27.9	55.7	111.4	139.3
580	89	32.1	64.3	128.6	160.7

HORSEPOWER RATINGS:

The rating shown are the power requirements for the pump. Gas engine power outputs must be approximately twice the pump power requirements shown above.

We recommend a 1.15 service factor be specified when selecting an electric motor as the power source. To compute specific pump horsepower requirements, use the following formula:

$$\frac{\text{GPM} \times \text{PSI}}{1450} = \text{HP}$$

SPECIAL NOTE:
 The theoretical gallons per revolution (gal/rev) is 0.155. To find specific outputs at various RPM, use the formula:

$$\text{GPM} = 0.155 \times \text{RPM}$$

Specifications

Model GP8065-Brine

	U.S.	(Metric)
Volume.....	Up to 105.7 GPM	(400 LPM)
Discharge Pressure	Up to 2000 PSI	(140 bar)
Power Consumption	147 BHP	110 kW
Speed	Up to 580 RPM.....	580 RPM
Inlet Pressure.....	Up to 29 PSI	(2.0 bar)
Plunger Diameter.....	2.55"	65mm
Plunger Stroke	2.83"	72mm
Crankshaft Diameter.....	2.76"	70mm
Key Width	0.55"	14mm
Crankshaft Mounting.....	Either side	
Shaft Rotation	Top of pulley towards manifold	
Temperature of Pumped Fluids.....	Up to 86° F*	(30° C)*
Inlet Ports.....	(2) 3" BSPP	
Discharge Ports	(2) 1-1/4" BSPP	
Weight.....	767 lbs.	(348kg)
Crankcase Oil Capacity	3.3 Gal.	(12.5 liters)
Fluid End Material.....	Nickle Aluminum Bronze	
NPSHR	23.6 ft-head	7.2 mWs

*Higher water temperatures possible with separate crankcase cooling system; the manufacturer is to be contacted in this case.

Consult the factory for special requirements that must be met if the pump is to operate beyond one or more of the limits specified above.

GP8065 HORSEPOWER REQUIREMENTS					
RPM	GPM	500 PSI	750 PSI	1000 PSI	2000 PSI
300	54	19.3	28.9	38.6	77.1
400	72	25.7	38.6	51.4	102.9
500	91	32.5	48.8	65.0	130.0
580	106	37.5	56.3	75.0	150.0

HORSEPOWER RATINGS:

The rating shown are the power requirements for the pump. Gas engine power outputs must be approximately twice the pump power requirements shown above.

We recommend a 1.15 service factor be specified when selecting an electric motor as the power source. To compute specific pump horsepower requirements, use the following formula:

$$\frac{\text{GPM} \times \text{PSI}}{1450} = \text{HP}$$

SPECIAL NOTE:
 The theoretical gallons per revolution (gal/rev) is 0.181. To find specific outputs at various RPM, use the formula:

$$\text{GPM} = 0.181 \times \text{RPM}$$

Exploded View - GP8055/GP8060/GP8065 - Brine

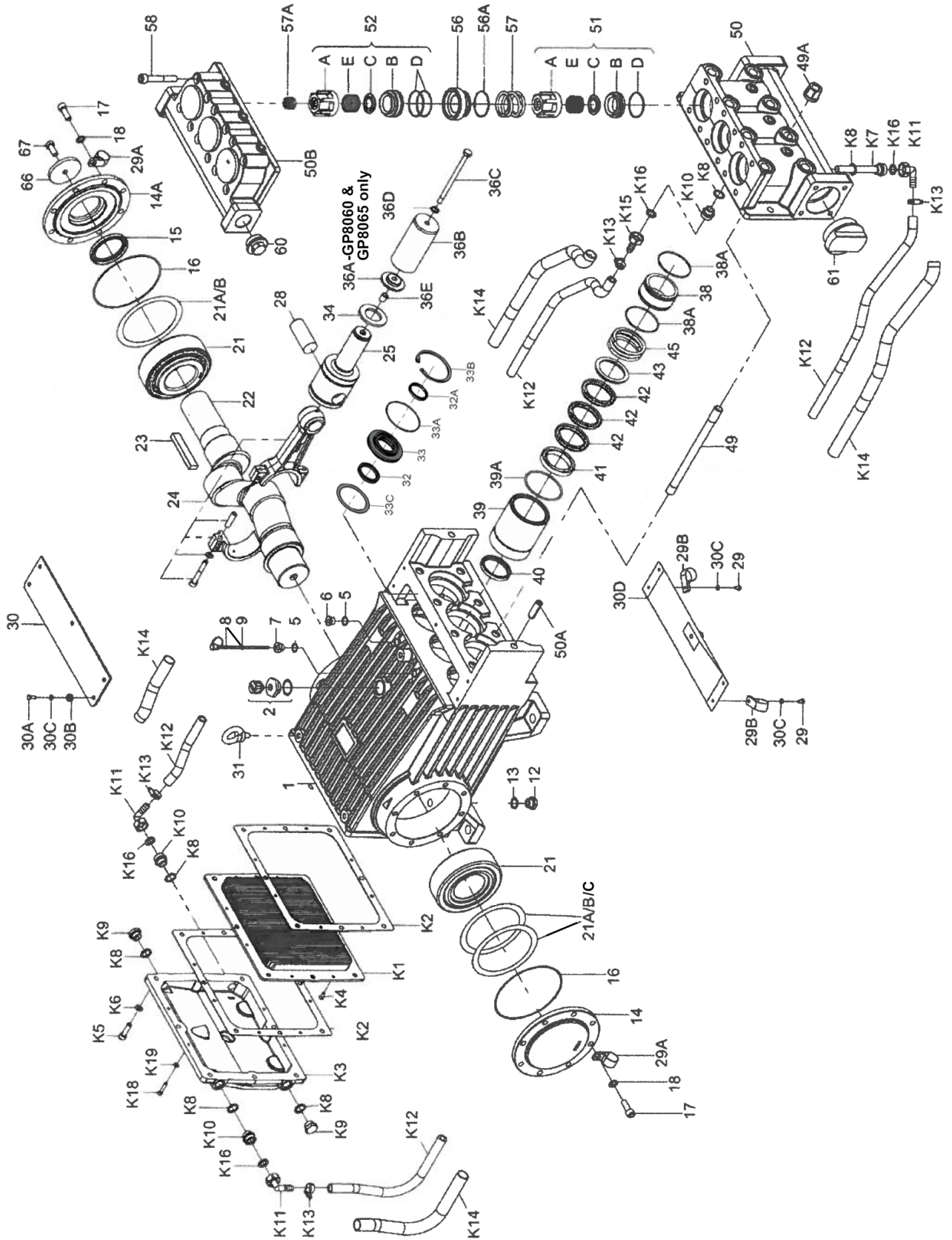

Part List - GP8055/GP8060/GP8065 - Brine

Item	Part	Description	Qty	Item	Part	Description	Qty
1	05380	Crankcase	1	40	06996	Seal Ring (GP8065)	3
2	06893	Oil Filler Plug Assembly with Vent	1	41	05276	Pressure Ring (GP8055)	3
5	22929	Copper Washer	2	41	05068	Pressure Ring (GP8060)	3
6	12256	Plug, 3/8" BSP	1	41	05117	Pressure Ring (GP8065)	3
7	05656	Plug for Oil Dipstick	1	42	05277	V Sleeve (GP8055)	9
8	05035	Oil Dipstick Assembly	1	42	05069	V Sleeve (GP8060)	9
9	06225	O-Ring	1	42	06997	V Sleeve (GP8065)	9
12	07109	Plug, 1/2" BSP	2	43	05278	Sleeve Support Ring (GP8055)	3
13	07182	Seal	2	43	05070	Sleeve Support Ring (GP8060)	3
14	05036	Bearing Cover Closed	1	43	05118	Sleeve Support Ring (GP8065)	3
14A	05298	Bearing Cover Open	1	45	05279	Seal Tension Spring (GP8055)	3
15	05112	Radial Shaft Seal	1	45	05071	Seal Tension Spring (GP8060)	3
16	05037	O-Ring	2	45	05119	Seal Tension Spring (GP8065)	3
17	05038	Hexagon Socket Screw	16	49	05072	Stud Bolt	8
18	05039	Spring Ring	16	49A	05073	Hexagon Nut	8
21	05044	Tapered Roller Bearing	2	50	05074-3000	Inlet Valve Casing	1
21A	05042	Fitting Disc	1-5	50A	13162	Centering Stud	2
21B	05043	Fitting Disc	1-5	50B	05075-3000	Discharge Valve Casing	1
21C	05113	Fitting Disc	1-5	51	05076-0100	Suction Valve Assembly	3
22	05299	Crankshaft	1	51A	04166	Spring Tension Cap	3
23	05300	Fitting Key	1	51B	05078-0100	Suction Valve Seat	3
24	05047	Connecting Rod Assembly	3	51C	05079-0100	Valve Plate	3
25	05048	Crosshead c/w Plunger	3	51D	07658-0001	O-Ring, Viton	3
28	05049	Crosshead Pin	3	51E	05080	Valve Spring	3
29	05051	Hexagon Screw	5	52	05082-0100	Discharge Valve Assembly	3
29A	05381	Bracket 1 for Cooling Hose	2	52A	04166	Spring Tension Cap	3
29B	05383	Bracket 2 for Cooling Hose	2	52B	05084-0100	Discharge Valve Seat	3
30	05052	Cover Plate	1	52C	05079-0100	Valve Plate	3
30A	07225-0100	Hexagon Screw	5	52D	05613	O-Ring, Viton	6
30B	13136	Grommet	5	52E	05080	Valve Spring	3
30C	08280	Washer	10	56	05085-0100	Discharge Valve Adaptor	3
30D	05050	Splash Cover	1	56A	05613	O-Ring, Viton	3
31	07623	Eye Bolt	4	57	05086	Pressure Spring	3
32	05058	Radial Shaft Seal	3	57A	07210-0100	Pressure Spring	3
32A	03118	Oil Scraper	3	58	05087-0100	Hexagon Socket Screw	12
33	03119	Seal Retainer	3	60	06909	Plug, 1 1/4" BSP	1
33A	05056	O-Ring	3	61	05088	Plug, 3" BSP	1
33B	05054	Clip Ring	3	66	05303	Disc for Crankshaft	1
33C	05059	Fitting Disc	3	67	13358	Hexagon Screw	1
34	05060	Oil Shield	3	K1	05026-0100	Cooling Vane Plate	1
36A	05063	Cover for Plunger Pipe (GP8060/GP8065)	3	K2	05027	Seal for Gear Cover	2
36B	05280	Plunger Pipe (GP8055)	3	K3	05028	Gear Cover	1
36B	05061	Plunger Pipe (GP8060)	3	K4	05029	Hexagon Head Countersunk Screw	4
36B	05115	Plunger Pipe (GP8065)	3	K5	07381	Hexagon Socket Screw	8
36C	05062	Tension Screw	3	K6	08041	Washer	8
36D	07665	Copper Washer	3	K7	05030	Connection for Oil Cooler	1
36E	06900	Centering Sleeve	3	K8	07661	Copper Seal	6
38	05283	Seal Case (GP8055)	3	K9	07109	Plug, 1/2" BSP	2
38	05064	Seal Case (GP8060/GP8065)	3	K10	05031	Connecting Branch	3
38A	13286-0001	O-Ring, Viton (GP8055)	6	K11	05032	Hose Adaptor	3
38A	06667-0001	O-Ring, Viton (GP8060/GP8065)	6	K12	05033	Tube for Cooler	2
39	05275	Seal Sleeve (GP8055)	3	K13	05402	Hose Clamp	4
39	05065	Seal Sleeve (GP8060)	3	K14	05403	Hose Guard	2
39	05116	Seal Sleeve (GP8065)	3	K15	05404	Hose Coupling Nut	1
39A	05066	O-Ring	3	K16	05405	Flat Gasket	4
40	07723	Seal Ring (GP8055)	3	K18	04158	Hexagon Socket Screw	4
40	05067	Seal Ring (GP8060)	3	K19	05053	Washer	4

Pump Repair Kits - GP8055/GP8060/GP8065 - Brine

Plunger Packing Kits

GP8055 - #09616

Item	Part #	Description	Qty.
38A	13286	O-Ring	6
38B	05281	Support Ring	6
39A	05066	O-Ring	3
40	07723	Seal Ring	3
42	05277	V-Sleeve	9

GP8060 - #09617

Item	Part #	Description	Qty.
38A	06667	O-Ring	6
39A	05066	O-Ring	3
40	05067	Seal Ring	3
42	05069	V-Sleeve	9

GP8065 - #09586

Item	Part #	Description	Qty.
38A	06667	O-Ring	6
39A	05066	O-Ring	3
40	06996	Seal Ring	3
42	06997	V-Sleeve	9

Oil Seal Kit - #09584

Item	Part #	Description	Qty.
32	05058	Radial Shaft Seal	3
33A	05056	O-Ring	3

Inlet Valve Kit - #09587-0100

Item	Part #	Description	Qty.
51	05076-0100	Inlet Valve Assembly	3
56A	05613	O-Ring	3

Discharge Valve Kit - #09588-0100

Item	Part #	Description	Qty.
52	05082-0100	Discharge Valve Assembly	3
56A	05613	O-Ring	3

GP8055/GP8060/GP8065 - Brine TOOL LIST AND TORQUE SPECIFICATIONS				
ITEM	PART #	DESCRIPTION	TORQUE Ft-lbs (NM)	TOOL NEEDED
17	05038	Hexagon Socket Screw	64 (87)	10mm allen wrench
24	05047	Connecting Rod Hexagon Socket Screw	37 (50)	8mm allen wrench
33B	05054	Clip Ring	n/a	Industrial Snap ring pliers
36C	05062	Tension Screw	30 (40)	16mm socket
49A	05073	Hexagon Nut (manifold)	265 (360)	30mm socket
51	05076-0100	Valve Assemblies	n/a	Valve puller (p/n 07662) - included with pump
52	05082-0100	Valve Assemblies	n/a	Valve puller (p/n 07662) - included with pump
58	05087	Hexagon Socket Screw	132 (180)	12mm allen wrench
K5	07381	Hexagon Socket Screw	n/a	8mm allen wrench

GP8055/GP8060/GP8065 - Brine Troubleshooting		
Problem	Cause	Solution
Pressure drops, water leaks	V-sleeves leak	Replace V-sleeves, examine surface of plunger
Pressure drops, pump becomes loud	Discharge or suction valve leaks	Replace valve
	Steam formation (cavitation)	Reduce suction height, reduce flow resistance in inlet line, clean inlet filter, lower water temperature
Irregular pressure	Worn valves	Examine valves
	O-Ring on the valves or inlet valve adapter leaks	Examine O-ring, examine valve casing for unevenness on the sealing surfaces
Oil leaks at visible part of plunger	Gear sealing is leaky	Examine seals and running surface of plunger
Dirty mile-colored frothy oil	Oil has mixed with water	Replace oil immediately, find and fix the cause
Oil leakage on the crankshaft	Shaft seal ring leaks	Check seal and shaft
Noise increases without loss of pressure	Worn bearing	Dismantle gear, examine all parts, replace worn parts, check oil level. If service life was too short, check for excess strain or whether lubrication intervals were too long. Only specified lubricants are to be used

Pump Repair Instructions - GP8055/GP8060/GP8065 - Brine Valve Inspection and Repair

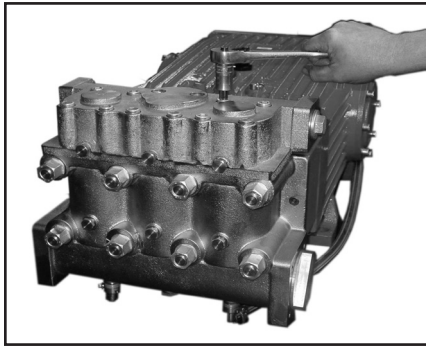

1) Remove bolts (58).

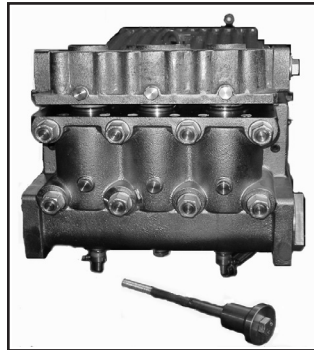

2) Remove discharge casing (50B) up and away.

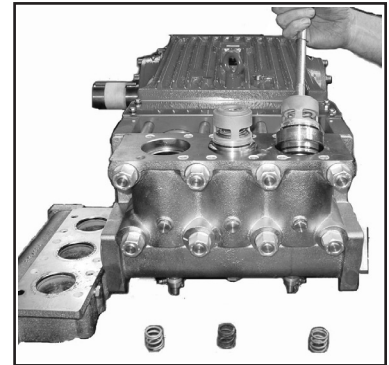

3) Take out pressure springs (57A). Pull out assembled valves (51 & 52) with fitting tool.

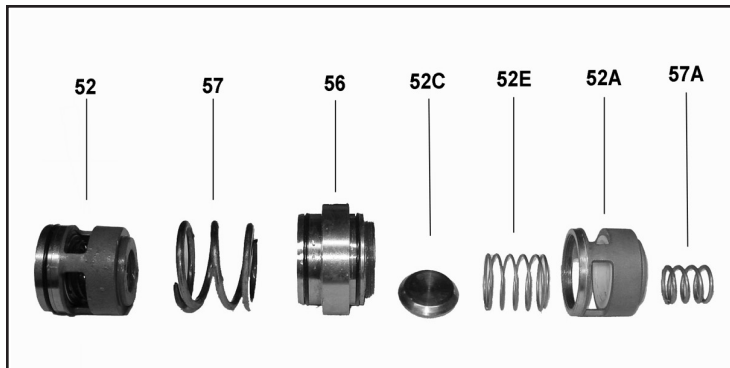

4) The spring tension cap (51A, 52A) is screwed together with the valve seat (51B or 52B). Screw off spring tension cap. Takeout springs (51E, 52E) and valve plate (51C, 52C). Check sealing surfaces and O-rings (51D, 52D). Replace worn parts. Coat threads of valve seat with silicon grease or molycote anti-seize Cu-7439 when reassembling. Before refitting the valves, clean the sealing surfaces in the casing and check for any damage. Tighten caps (58) at 133 Ft-lbs; check torque tension after 8-10 operating hours.

To Check Seals and Plunger Pipe

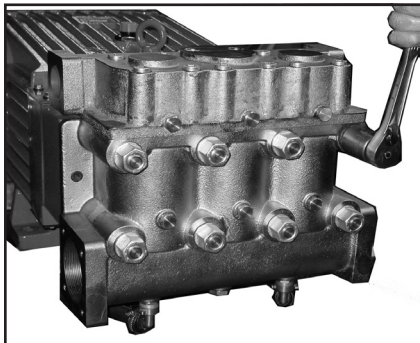

5) Remove hexagon nuts (49A) and valve casing together with seal case (38) from crankcase (1). If necessary, carefully tap the valve casing (50) past the centering stud (50A) using a rubber hammer.

IMPORTANT! If necessary, support the valve casing by resting it on wooden blocks or by using a pulley.

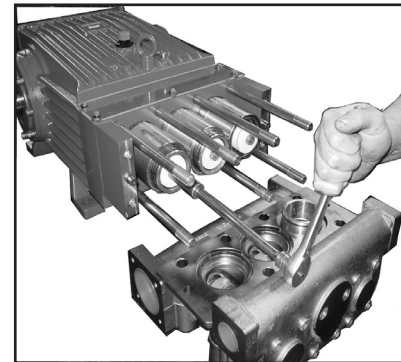

6) Remove tension screw (36C) and take seal sleeve (39) together with all mounted parts out of the drive. Pull plunger pipe out of the seal assembly and check for any damage. Carefully, remove seal rings (40) and sleeves (42) with a screw driver.

Pump Repair Instructions - GP8055/GP8060/GP8065 - Brine

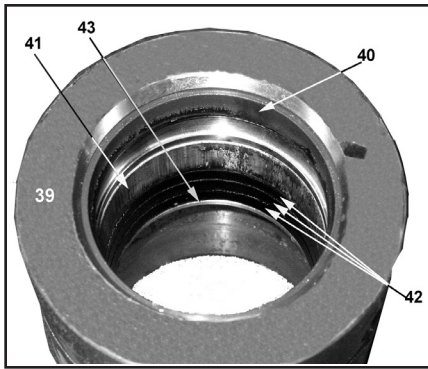

7) **Important!** Be careful not to damage the seal sleeve (39) and pressure ring (41). Check the inner diameter of the pressure ring for wear and if necessary replace together with seals (40) and (42). Clean all parts. New parts should be lightly coated with silicon grease before installation. Inert the seal unit (40, 41, 42 43) into the sleeve. Push the ceramic plunger carefully through the seals from the crankcase side. If necessary, the seals can be held tightly using a suitable pipe support held on the other side of the seal sleeve.

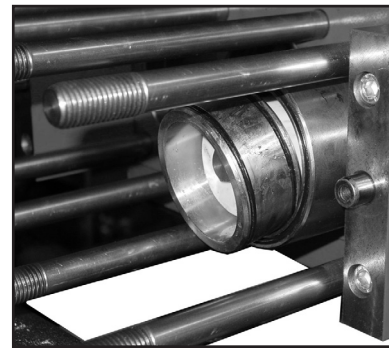

8) Take out the seal case (38) from the valve (if necessary secure 2 screwdrivers in the front O-ring groove to extract seal casing from valve casing). Coat seals with silicon grease before installing.

Important! Mounting surfaces of the crankcase and the valve casing must be clean and free of damage. The components must lie exactly and evenly on one another. The same exactness applies for all centering positions in the crankcase, pressure and valve casing.

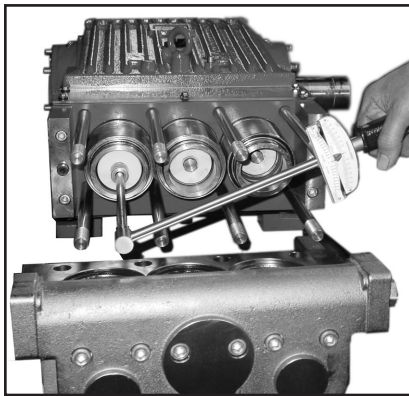

9) Coat the seal sleeve lightly with anti-corrosive grease (e.g. molycote no. Cu-7439) in its fitted area towards the crankcase. Insert the seal sleeves in to their crankcase fittings. Coat the threads of the tension screw (36C) lightly with thread glue and insert it together with a new copper ring (36D) through the ceramic pipe. Turn the pump per hand until the plunger (25) rests against the plunger pipe. Tighten the tension screw at 30 Ft.-lbs.

Important! Thread glue must never come between the plunger pipe (36B) and centering sleeve (36E). Overtensioning of the plunger pipe by excessive tightening of the tension screw and/or dirt or damage on the mounting surfaces can lead to plunger pipe breakage. Insert the seal tension spring (45) and O-ring (39A) in to the seal sleeve (39).

Replacing Valve Casing:

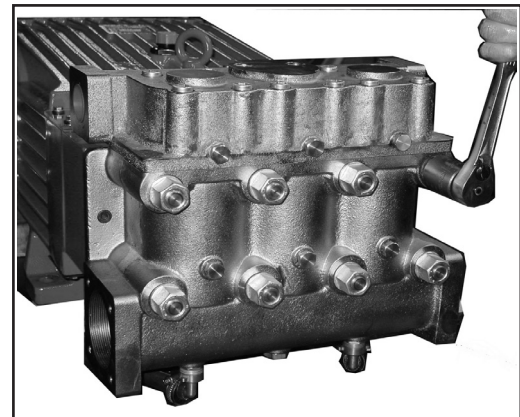

10) Put seal cases (38) in the centering holes of the valve casing, then push valve casing carefully on to centering studs (50A). Tighten hexagon screws (49A) evenly and crosswise at 266 Ft.-lbs.

Important! The torque tension on the screws (49A) must be checked after 8-10 operating hours; the pump must be at zero pressure. Thereafter, the tension is to be checked every 200 operating hours.

Pump Repair Instructions - GP8055/GP8060/GP8065 - Brine

To Dismantle Crankcase Gear

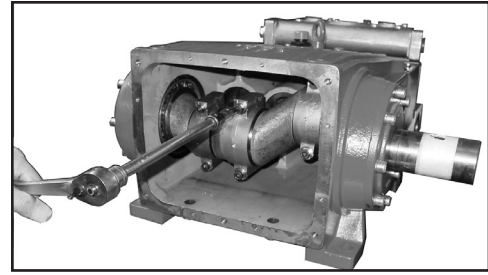
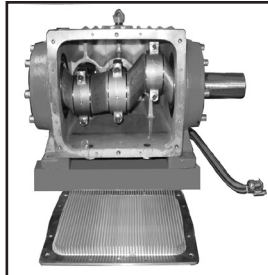
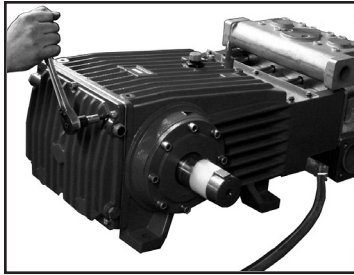

11) Take out plungers and seal sleeves as described above. Drain the oil by taking off the plug (12). After removing the clip ring (33B), lever out the seal retainer (33) with a screwdriver. Open hose adaptor (K11) and remove gear cover (K3). Remove the cooling vane plate (K1) by removing the screws (K4)

12) Remove the connecting rod screws (24). **Important!** Connecting rods are marked 1 to 3 for identification. Do not twist connecting rod halves or interchange them. When reassembling, the connecting rod must be fitted in their exact original position on the crankshaft journals.

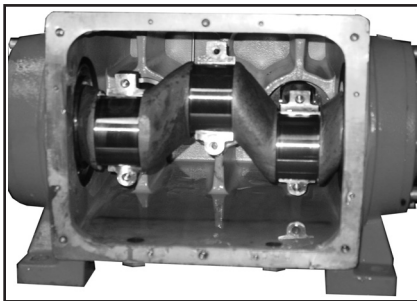

13) Push connecting rod halves together with the crosshead as far as possible into the crosshead guide. Take out bearing cover (14/14A) and push out crankshaft taking particular care that the con rod doesn't get bent. Check surfaces on the connecting rods (24), crankshaft (22) and crossheads (25). Check the surfaces of the crosshead guides in the crankcase for any unevenness.

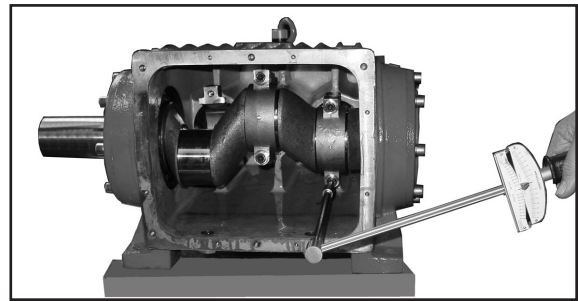

14) Reassemble in reverse order. Thread the long end of the crankshaft together with the inner bearing rings into the crankcase; then mount outer bearing ring (20) and spacer ring (22A). Mount connecting rod halves in their exact original position and tighten at 37 Ft-lbs. **Important!** Connecting rods must be able to move slightly sideways on the stroke journals.

15) Mount bearing cover (14A) and tighten screws (17) to 64 Ft-lbs. Adjust axial play (clearance) on the crankshaft to minimum 0.1 mm / max. 0.15 mm using shims (21A/21B). The shaft should turn easily with little clearance. Connecting rod must sit exactly in the middle of each crank pin. Fit the bearing cover (14) and tighten the screws (17) at 64 Ft-lbs. Seal (32A) must always be installed so that the seal lip on the inside diameter faces the oil. Possible axial float of the seal adaptor (33) to be compensated with shims (33C).

Mount cooling plate (K1) and gear cover (K3) with their respective seals (K2). When assembling the cooling circuit line, make sure that the oil cooler connection (K7) is always joined to the upper connection (K3) of the gear cover.

Pump Dimensions (mm) - GP8055/GP8060/GP8065 - Brine

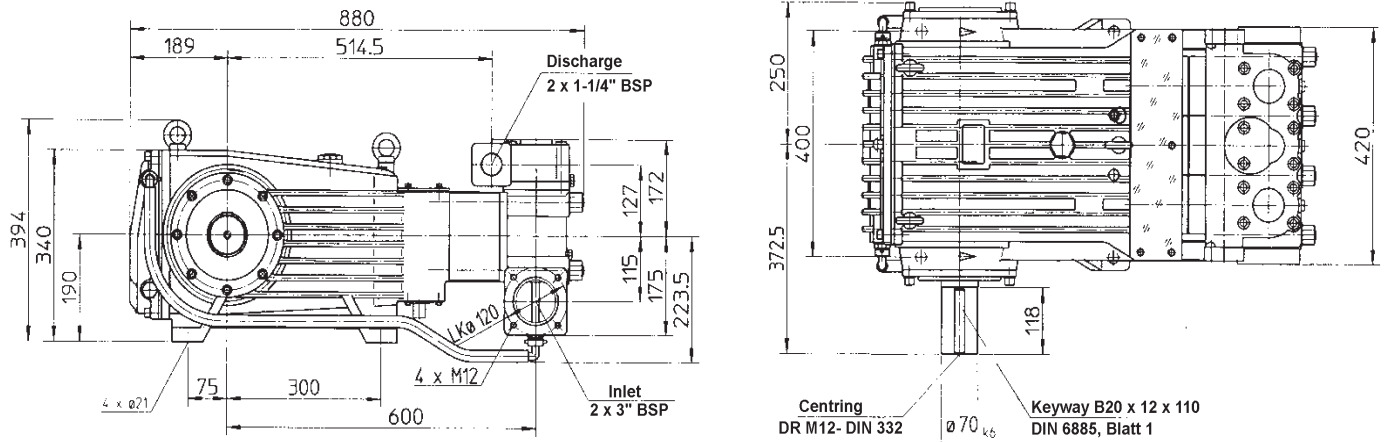

GIANT INDUSTRIES LIMITED WARRANTY

Giant Industries, Inc. pumps and accessories are warranted by the manufacturer to be free from defects in workmanship and material as follows:

1. Five (5) years from the date of shipment for all pumps used in portable pressure washers with NON-SALINE, clean water applications.
2. Two (2) years from the date of shipment for Giant pumps used in car wash applications.
3. One (1) year from the date of shipment for all other Giant industrial and consumer pumps.
4. Six (6) months from the date of shipment for all rebuilt pumps
5. Ninety (90) days from the date of shipment for all Giant accessories.

This warranty is limited to repair or replacement of pumps and accessories of which the manufacturer's evaluation shows were defective at the time of shipment by the manufacturer. The following items are NOT covered or will void the warranty:

1. Defects caused by negligence or fault of the buyer or third party.
2. Normal wear and tear to standard wear parts.
3. Use of repair parts other than those manufactured or authorized by Giant.
4. Improper use of the product as a component part.
5. Changes or modifications made by the customer or third party.
6. The operation of pumps and or accessories exceeding the specifications set forth in the Operations Manuals provided by Giant Industries, Inc.

Liability under this warranty is on all non-wear parts and limited to the replacement or repair of those products returned freight prepaid to Giant Industries which are deemed to be defective due to workmanship or failure of material. A Returned Goods Authorization (R.G.A.) number and completed warranty evaluation form is required prior to the return to Giant Industries of all products under warranty consideration. Call (419)-531-4600 or fax (419)-531-6836 to obtain an R.G.A. number.

Repair or replacement of defective products as provided is the sole and exclusive remedy provided hereunder and the MANUFACTURER SHALL NOT BE LIABLE FOR FURTHER LOSS, DAMAGES, OR EXPENSES, INCLUDING INCIDENTAL AND CONSEQUENTIAL DAMAGES DIRECTLY OR INDIRECTLY ARISING FROM THE SALE OR USE OF THIS PRODUCT.

THE LIMITED WARRANTY SET FORTH HEREIN IS IN LIEU OF ALL OTHER WARRANTIES OR REPRESENTATION, EXPRESS OR IMPLIED, INCLUDING WITHOUT LIMITATION ANY WARRANTIES OR MERCHANTABILITY OR FITNESS FOR A PARTICULAR PURPOSE AND ALL SUCH WARRANTIES ARE HEREBY DISCLAIMED AND EXCLUDED BY THE MANUFACTURER.



WARNING: This product might contain a chemical known to the State of California to cause cancer, and birth defects or other reproductive harm.

For more information go to www.P65Warnings.ca.gov

GIANT
Performance Under Pressure

GIANT INDUSTRIES, INC.

900 N. Westwood Ave.

Toledo, Ohio 43607

(419) 531-4600

FAX (419) 531-6836

www.giantpumps.com

© Copyright 2020 Giant Industries, Inc.