

Model LP200GB-SS-180

Triplex Ceramic
Plunger Pump
Operating Instructions/
Repair and Service Manual

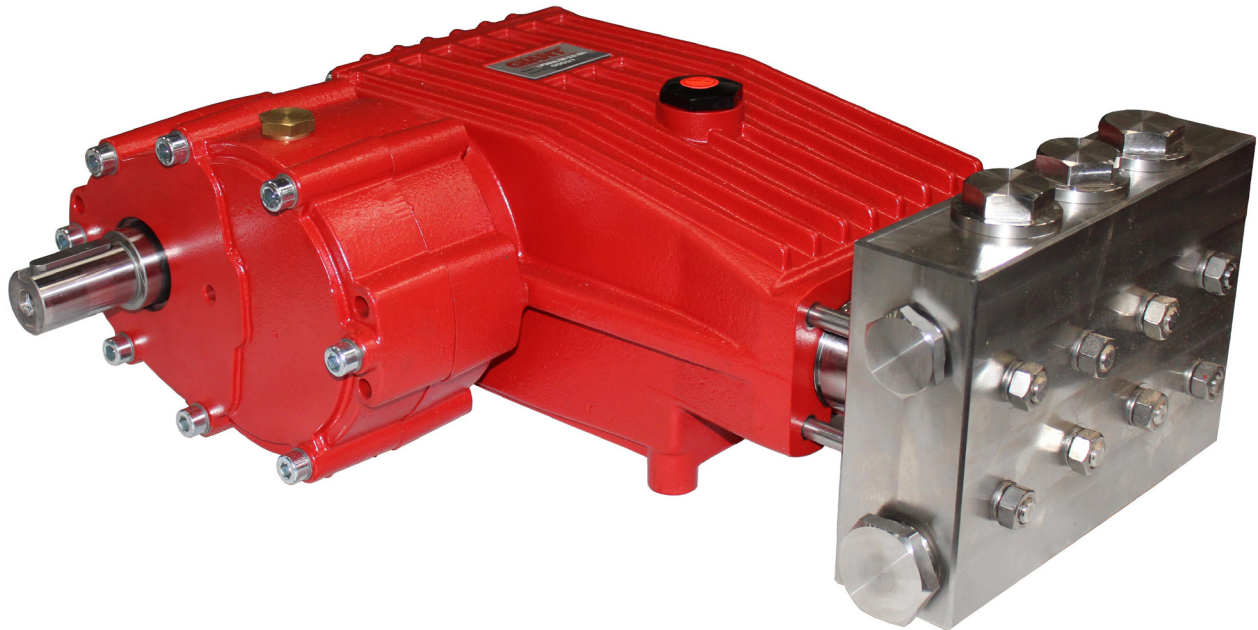

Updated 02/23

Contents:

Installation Instructions:	page 2
LP200GB-SS-180 Specifications:	page 3
Exploded View:	page 4
Parts List/Kits:	page 5
Repair Instructions:	pages 6-9
Torque Specifications:	page 8
Pump Mounting Selection Guide:	page 9
Trouble Shooting:	page 10
Maintenance/Spare Parts List:	page 10
Dimensions:	page 11
Warranty Information:	back page

Installation Instructions

Operation and Maintenance

Check oil level prior to starting and ensure trouble free water supply.

IMPORTANT! If there is a **danger of frost**, the water in the pump and in the pump fittings (particularly the unloader valve) must be emptied. The second discharge port can also be used and the pump run “dry” for 1-2 minutes for this purpose.

Oil: Use only 118 fluid ounces (3.5 L) of SAE 90 Industrial gear lube oil. (Giant’s p/n 01154)

Initial change after 50 operating hours and then every 1000 operating hours, or after one year if used less.

Caution! When operating in damp places or with high temperature fluctuations, condensate (frothy oil) might occur in the gear box. In this situation, change the oil immediately. **Keep NPSH under control.**

Maximum input pressure is 145 PSI (10 bar), the maximum suction head is -4.35 PSI (-0.3 bar). Make sure that suction pulsation is sufficiently dampened. Water column resonance must be avoided.



Safety Rules

Pump operation without safety valve as well as any excess in temperature or speed limits automatically voids the warranty. The safety valve must be regulated in accordance with the guidelines for liquid spraying units so that the admissible operating pressure can not be exceeded by more than 10%.

When the pump is in operation, the open shaft end must be covered up by a shaft protector (21). For direct drive operations, the driven shaft side and coupling must have a guard over the connected area.

Pressure in discharge line and in pump must be at zero before any maintenance to the pump takes place. Close the fluid supply to the inlet port(s). Disconnect fuses to ensure that the driving motor does not accidentally get switched on. Make sure that all parts on the pressure side of the unit are vented and re-filled, with pressure at zero, before starting the pump.

In order to prevent air, or air/water mixture being absorbed and to prevent cavitation occurring, the pump-npshr, positive suction head and water temperature must be kept under control.

Required NPSH refers to water: Specific weight 0.0624 lb/ft³ (1kg/dm³), viscosity 1°E at maximum permissible revolutions.

Cavitation and/or compression of gases lead to uncontrollable pressure kicks which can ruin pump and unit parts and also be dangerous to the operator or anyone standing nearby.

Giant pumps are suitable for pumping clean water and other non-aggressive or abrasive media with a specific weight similar to water.

Before pumping other liquids - especially inflammable, explosive and toxic media - the pump manufacturer must under all circumstances be consulted with regard to the resistance of the pump material. It is the responsibility of the equipment manufacturer and/or operator to ensure that all pertinent safety regulations are adhered to.

NOTE: Contact Giant Industries for Service School Information. Phone: (419)-531-4600

Model LP200GB-SS-180 Specifications

	<u>U.S.</u>	<u>Metric</u>
Flow	19.0 GPM	72.1 L/min
Pressure	3000 PSI	200 bar
Crankshaft Speed.....		1000 RPM
Input Speed		2000 RPM
Power Required.....	38.1 BHP	28.4 kW
Inlet Pressure	-4.35 to 90 PSI	-0.3 to 6.2 Bar
Plunger Diameter.....	1.10"	28 mm
Stroke	1.65"	42 mm
Crankcase Oil Capacity	114 fl.oz.	3.6 Liters
Temperature of Pumped Fluids @ 1000 RPM.....	140 °F	60 °C
Temperature of Pumped Fluids @ 500 RPM.....	160 °F	71 °C
Inlet Port		(3) 1-1/4" BSP
Discharge Port.....		(3) 1" BSP
Crankshaft Mounting		Either Side
Pinion Shaft Rotation.....		Towards Back of the Pump
Weight	119 lbs.	54 kg
Pinion Shaft Diameter.....		35 mm

Horsepower Ratings:

We recommend a 1.15 service factor be specified when selecting an electric motor as the power source.

To compute electric motor horsepower required, use the following formula: $HP = (GPM \times PSI) / 1450$.

The formula to determine the horsepower required for a gas engine is: $HP = (GPM \times PSI) / 1150$.

The formula to determine the horsepower required for a diesel engine is: $HP = (GPM \times PSI) / 1250$.

For the Application of a Hydraulic Motor:

To Determine the Torque of a Hydraulic Motor -- $(GPM \times PSI \times 36.77) / RPM = \text{Torque (in-lbs)}$

Calculating RPM / GPM of Pump:

A pump must be connected to an electric motor or gas or diesel engine with the correct ratio of pulleys and belts to attain the required speed and GPM. The use of a Variable Frequency Drive (VFD) may also

be used to control the RPM of a properly sized electric motor when variable flows are required.

$$(\text{Max. Pump RPM} / \text{Rated Pump GPM}) \times \text{Required Pump GPM} = \text{Required Pump RPM}$$

To calculate a pulley diameter one (1) pulley diameter and the required pump RPM must be known:

$$(\text{Pump RPM} \times \text{Pump Pulley Diameter}) / \text{Motor RPM} = \text{Motor Pulley Diameter}$$

$$(\text{Motor RPM} \times \text{Motor Pulley Diameter}) / \text{Pump RPM} = \text{Pump Pulley Diameter}$$

Exploded View - LP200GB-SS-180

Important! The stainless steel valve plugs (48) can seize when being screwed out of the casing. To release tension beforehand, strike the plugs 1-2 times with a steel hammer on the top before screwing them out. Coat threads with antiseize (e.g. Fel-Pro Nickel Anti-Seize 51119)

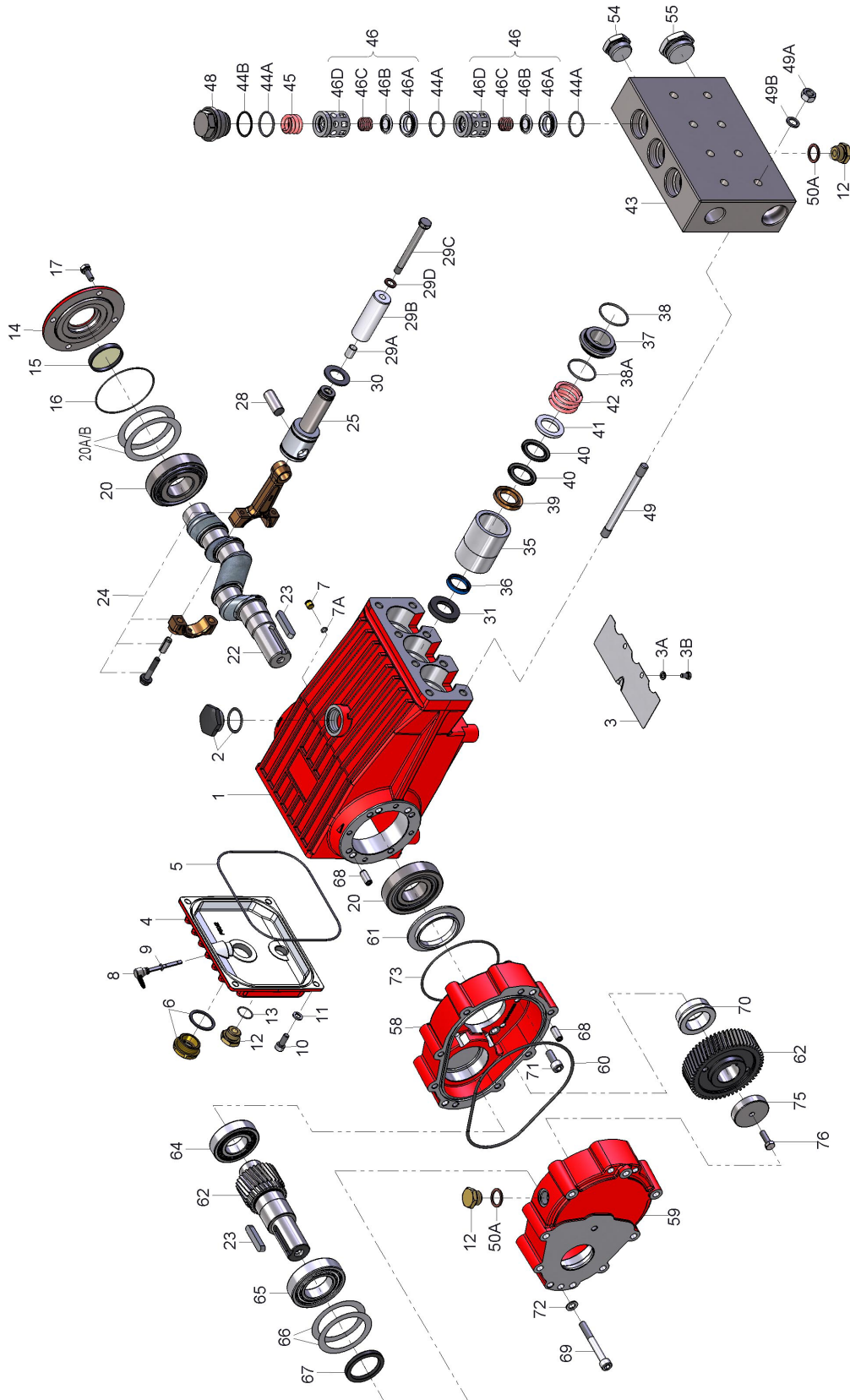

LP200GB-SS-180 Parts List

<u>ITEM</u>	<u>PART</u>	<u>DESCRIPTION</u>	<u>QTY</u>	<u>ITEM</u>	<u>PART</u>	<u>DESCRIPTION</u>	<u>QTY</u>
1	03190	Crankcase	1	39	13197	Pressure Ring	3
2	13000	Oil filler Plug Assembly	1	40	13115	V-Sleeve	6
3	05940	Cover Plate	1	41	13198	Support Ring	3
3A	07223-0100	Spring Ring	2	42	07173	Tension Spring	3
3B	05051	Hexagon Screw	2	43	13040	Valve Casing	1
4	06085	Crankcase Cover	1	44A	07150	O-Ring	9
5	07104	O-ring, Crankcase Cover	1	44B	06266	Support Ring for O-Ring	3
6	05943	Oil Sight Glass	1	45	06078	Compression Spring	3
7	03191	Lid	2	46	07060	Valve Assy, Complete	6
7A	01009	O-Ring	2	46A	07064	Valve Seat	6
8	06086	Oil Dipstick Assembly	1	46B	07063	Valve Plate	6
9	01009	O-Ring, Dipstick Assembly	1	46C	07062-0100	Valve Spring	6
10	01010	Cylinder Screw	4	46D	07066	Spacer Pipe	6
11	01011-0400	Spring Ring	4	48	06077	Plug	3
12	07109	Plug, 1/2" BSP	4	49	07157	Stud Bolt	8
13	06015	O-Ring	1	49A	07158	Hexagon Nut	8
14	07111	Bearing Cover	1	49B	07159	Disc	8
15	08439	Lid	1	50A	07661	Copper Seal Ring	1
16	07113	O-Ring	1	54	13044	Plug, 1" BSP	1
17	07114	Hexagon Screw	4	55	13151	Plug 1-1/4" BSP	1
20	07116	Taper Roller Bearing	2	58	03194	Bottom Casing for Gear	1
20A	07117	Fitting Disc, 0.1 mm	1-3	59	03195	Top Casing for Gear	1
20B	13001	Fitting Disc, 0.15 mm	1-3	60	03196	O-Ring	1
20C	04091	Fitting Disc, 0.2 mm (may not be present)	1-3	61	03197	Centering Ring for Gear	1
				62	03198	Gear Wheel Set 1 : 2.0	1
22	03192	Crankshaft	1	64	03199	Cylinder Roller Bearing	1
23	13243	Fitting Key	2	65	03200	Cylinder Roller Bearing	1
24	13340	Connecting Rod Assembly	3	66	03201	Shim, 0.1 mm	3
24A	13227	Hex Screw	3	67	05058	Radial Shaft Seal	1
24B	13278	Spring Washer	3	68	04744	Cylindrical Pin	3
25	13341	Crosshead / Plunger Assy.	3	69	03202	Hexagon Socket Screw	8
28	13232	Crosshead Pin	3	70	03203	Spacer Ring for Gear	1
29A	07125	Centering Sleeve	3	71	07008	Hexagon Socket Screw	4
29B	13220	Plunger Pipe	3	72	08041	Washer	8
29C	13031	Tension Screw	3	73	03204	O-Ring	1
29D	07755	Copper Ring	3	75	03205	Disc for Crankshaft	1
30	07779	Drip Shield	3	76	03206	Hexagon Screw	1
31	07133	Radial Shaft Seal	3		03055	Plunger Conversion Assembly (29B-D, 35-42)	
35	13196	Seal Sleeve	3				
36	13228	Leakage Seal	3				
37	07170	Seal Case	3				
38	07140	O-Ring	3				
38A	12055	O-Ring	3				

*BSP to NPT Adapters/Seals (sold separately)
 Inlet Port = 13377 (Adapter) / 13376 (Seal)
 Discharge Port = 13373+ (Adapter) / 13372 (Seal)

LP200GB-SS-180 Pump Repair Kits

Plunger Packing Kits - #9307

<u>Item</u>	<u>Part#</u>	<u>Description</u>	<u>Qty.</u>
36	13228	Leakage Seal	3
38	07140	O-Ring	3
38A	12055	O-Ring	3
40	13115	V-Sleeve	6

Valve Kit - #09196

<u>Item</u>	<u>Part#</u>	<u>Description</u>	<u>Qty.</u>
44A	07150	O-Ring	9
44B	06266	Support Ring	3
46A	07064	Valve Seat	3
46B	07062-0100	Valve Plate	3
46C	07062	Valve Spring	3

Oil Seal Kit - #09577

<u>Item</u>	<u>Part#</u>	<u>Description</u>	<u>Qty.</u>
31	07133	Oil Seal Kit	3

LP200GB-SS-180 Repair Instructions

NOTE: Always take time to lubricate all metal and non-metal parts with a light film of oil before reassembling. This step will help ensure proper fit, at the same time protecting the pump non-metal parts (elastomers) from cutting and scoring.

TO CHECK VALVES

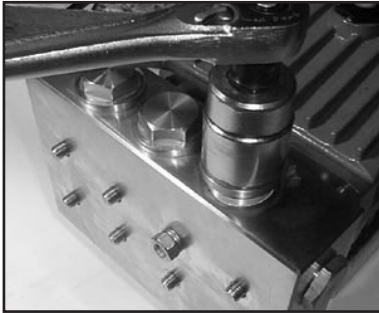

- 1) Loosen and remove tension plugs (48) with a 36mm socket wrench.

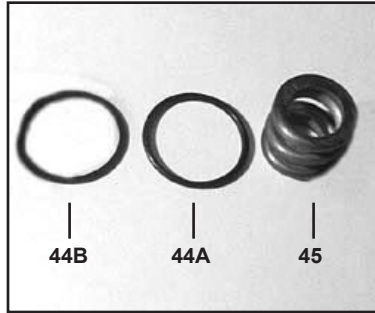

- 2) Remove the support ring (44B), O-ring (44A) and tension spring (45).

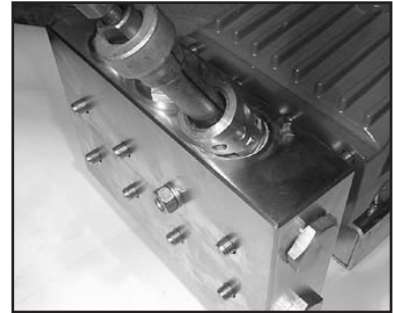

- 3) Take out discharge valve assemblies (46) by pulling them upwards out of the valve casing (43) with a snap-ring tongs or any other pull-off device. Then remove inlet valves in the same way.

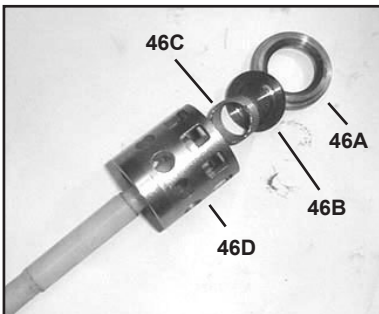

- 4) Loosen valve seats (46A) and valve spring (46C) from spacer pipe (46D) by lightly hitting the valve plate (46B) with a plastic stick. LP600/ LP600-4000 pumps have an additional valve spring guide (46E). Check sealing surface and replace worn parts. Reassemble with new O-rings (44A) if possible and oil them before installing.



- 5) Tighten up tension plugs (48) to 107 ft.-lbs. (125 NM)

LP200GB-SS-180 Repair Instructions

TO CHECK SEALS

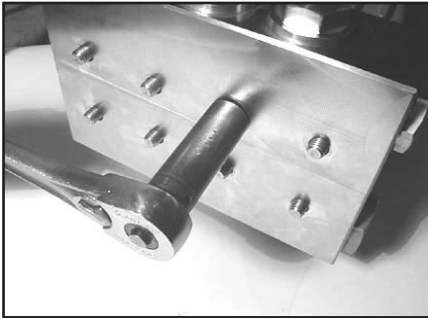

- 6) Loosen the 8 nuts (49A) with a 19mm socket and pull off valve casing (43) to the front.



- 7) Pull seal sleeves (35) out of guides in crankcase (1).

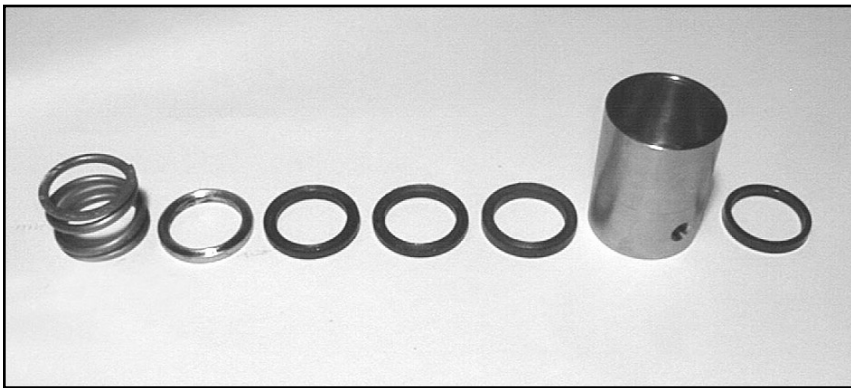

- 8) Remove the tension spring (42), support ring (41), v-sleeves (40), pressure ring (39), from the seal sleeve (35). Examine seals (36) carefully and replace if worn. Clean all parts.

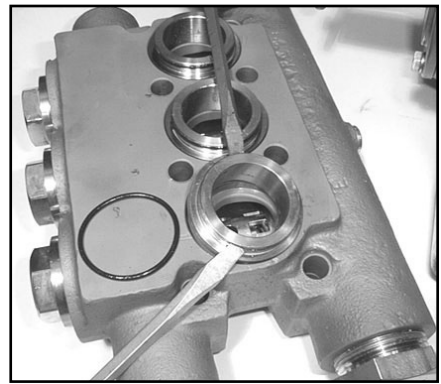

- 9) Remove seal case (37) from valve casing (43) and inspect O-rings (38/38A).

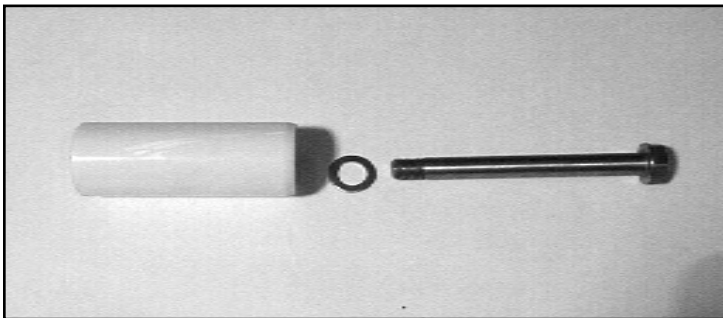

- 10) Check plunger surface (29B). If plunger pipe is worn, loosen tension screws (29C) and pull off plunger pipe to the front. Clean front surface of plunger (25) thoroughly. Apply a thin coat of Loctite to the tension screw threads (29C). **Note: Care must be taken that no glue gets between the plunger pipe (29B) and the centering sleeve (29A).** Add new copper ring (29D).



- 11) Place new plunger pipe (29B) carefully through the oiled seals and push seal sleeve (35) with plunger pipe into the crankcase guide. **Note: Make sure weep hole is facing down.**

LP200GB-SS-180 Repair Instructions

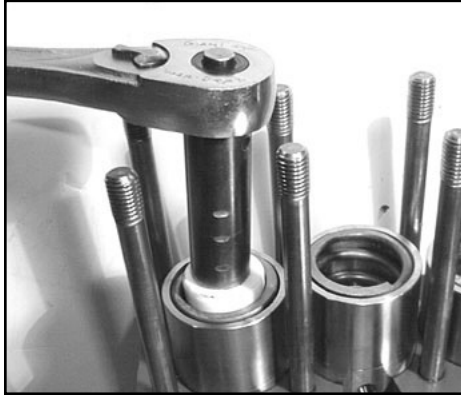

- 12) Tighten the tension screws (29C) to 310 in.-lbs. (35NM). The plunger pipe (29B) should not be strained by over tightening of the tension screw (29C) or through damage to the front surface of the plunger; otherwise, it will probably break.

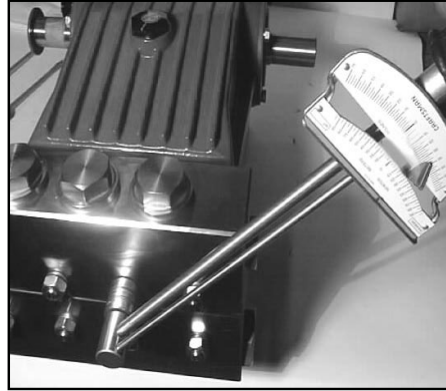

- 13) Place entire manifold/ seal sleeve assembly over the studs and push firmly until seated against the crankcase.

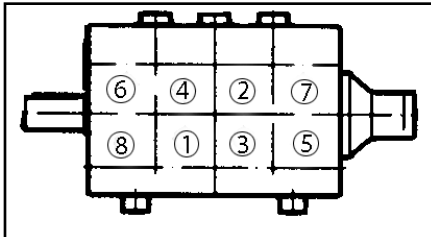

- 14) Tighten hex nuts (49A) in a crosswise pattern (shown above) to 59 ft.-lbs.

LP200GB-SS-180 Torque Specifications				
Position	Item #	Description	Lubrication Info	Torque Amount
1	07759	Crankcase	Molycote Cu-Paste	
6	05943	Oil Sight Glass	Loctite 572	29 ft.-lbs. (40 Nm)
10	01010	Cylinder Screw		221 in.-lbs. (25 Nm)
12	07109	Plug, 1/2" BSP		29 ft.-lbs. (40 Nm)
17	07114	Hexagon Screw		221 in.-lbs. (25 Nm)
24	13340	Inner Hex Screw, Connecting Rod		22 ft.-lbs. (30 Nm)
29C	13031	Tension Screw, Plunger	Loctite 243	26 ft.-lbs. (35 Nm)
29D	07161A-0100	Seal Sleeve	Loctite 577	
31	07133	Radial Shaft Seal	Loctite 403	
48	06077	Plug, Discharge		107 ft.-lbs. (145 Nm)
49	07157	Stud Bolt	Loctite 270	
49A	07158	Hexagon Nut, Stud Bolts		59 ft.-lbs (80 Nm)

LP200GB-SS-180 - Repair Instructions

TO DISMANTLE GEAR END

After removing valve casing (43) and plunger pipe (29B), drain the oil. Remove the gear cover (4) and bearing cover (14). Loosen connecting rod screws (24A) and push the front of the connecting rod (24) forward as far as possible into the crosshead guide.

IMPORTANT! Connecting rods (24) are marked for identification. Do not twist connecting rod halves. Connecting rod is to be reinstalled in the same position on shaft journals.

IMPORTANT! Do not bend the connecting rod (24) shanks. Check crankshaft (22) and connecting rod (24) surfaces, radial shaft seals (15) and taper roller bearings (20).

To remove the oil seals (31) use a wooden rod and sharply hit down on the oil seals from the crankcase (1). Note: when replacing the oil seals, apply a small amount of locktight to the outside edges of each oil seal before re-inserting them into the crankcase.

To Dismantle Reduction Gear

Remove screws (69). Remove bottom casing (58); it may be necessary to use a rubber mallet. Remove screw (76) and disc (75). Pull gear wheel (62) off of the shaft. Remove screws (71), top casing (58) and centering ring (61).

Turning the crankshaft (22) slightly, hit it out carefully to the side with a rubber hammer.

To Reassemble

Using a soft tool, press in the outer bearing ring until the outer edge lines up with the outer edge of the bearing hole. Remove bearing cover (14) together with radial shaft seal (15) and o-ring (16). Fit crankshaft (22) through bearing hole on the opposite side. Press in outer bearing and tighten it inwards with the bearing cover, keeping the crankshaft in vertical position and turning slowly so that the taper rollers of the bearings touch the edge of the outer bearing ring. Adjust axial bearing clearance to at least 0.1mm and maximum 0.15mm by placing fitting discs (20A and 20B) under the bearing cover.

IMPORTANT! After assembly has been completed, the crankshaft should turn easily with very little clearance. Tighten connecting rod screws (24A) to 22 ft.-lbs. (30 Nm) Re-assemble the fluid end (see instructions above).

If cylinder roller bearing (65) was removed, heat them up (before pressing onto the pinion shaft). Slightly press the gearwheel (62) onto the crankshaft (22) so that remaining portion of the gearwheel set can be positioned in the correct manner. Carefully, tap the gearwheel and the pinion (simultaneously) onto the crankshaft and into the bearing seat. Reassemble remaining gearbox parts making sure not to damage the radial shaft seal (67) or the o-ring (60).

Important! Before putting the pump into operation, turn the reduction gear (by hand) at least four times in each direction (to ensure proper alignment).

Reassemble connecting rods (24), shaft cover (14) and crankcase cover (4) and properly torque screws (17 & 10).

Pump Mounting Selection Guide

Rails

07357 - Plated Steel Channel Rails
(L=11.75" x W=1.88" x H=3.00")

Pump System Malfunction

<u>MALFUNCTION</u>	<u>CAUSE</u>	<u>REMEDY</u>
The Pressure and/ or the Delivery Drops	Worn packing seals Broken valve spring Belt slippage Worn or Damaged nozzle Fouled discharge valve Fouled inlet strainer Worn or Damaged hose Worn or Plugged relief valve on pump Cavitation Unloader	Replace packing seals Replace spring Tighten or Replace belt Replace nozzle Clean valve assembly Clean strainer Repair/Replace hose Clean, Reset, and Replace worn parts Check suction lines on inlet of pump for restrictions Check for proper operation
Water in crankcase	High humidity Worn seals	Reduce oil change interval Replace seals
Noisy Operation	Worn bearings Cavitation	Replace bearings, Refill crankcase oil with recommended lubricant Check inlet lines for restrictions and/or proper sizing
Rough/Pulsating Operation with Pressure Drop	Worn packing Inlet restriction Accumulator pressure Unloader Cavitation	Replace packing Check system for stoppage, air leaks, correctly sized inlet plumbing to pump Recharge/Replace accumulator Check for proper operation Check inlet lines for restrictions and/or proper size
Pressure Drop at Gun	Restricted discharge plumbing	Re-size discharge plumbing to flow rate of pump
Excessive Leakage	Worn plungers Worn packing/seals Excessive vacuum Cracked plungers Inlet pressure too high	Replace plungers Adjust or Replace packing seals Reduce suction vacuum Replace plungers Reduce inlet pressure
High Crankcase Temperature	Wrong Grade of oil Improper amount of oil in crankcase	Giant oil is recommended Adjust oil level to proper amount

Preventative Maintenance Check List & Recommended Spare Parts List						
Check	Daily	Weekly	50 Hrs.	Every 500 Hrs.	Every 1500 Hrs.	Every 3000 Hrs.
Oil Level/Quality	X					
Oil Leaks	X					
Water Leaks	X					
Belts, Pulley		X				
Plumbing		X				
Recommended Spare Parts						
Oil Change (1 Gallon) p/n 01154			X	X		
Plunger Seal Kit (1 kit/pump) See page 5					X	
Valve Repair Kit (2 kits/pump) See page 5						X

Pump Dimensions - Inches(mm)

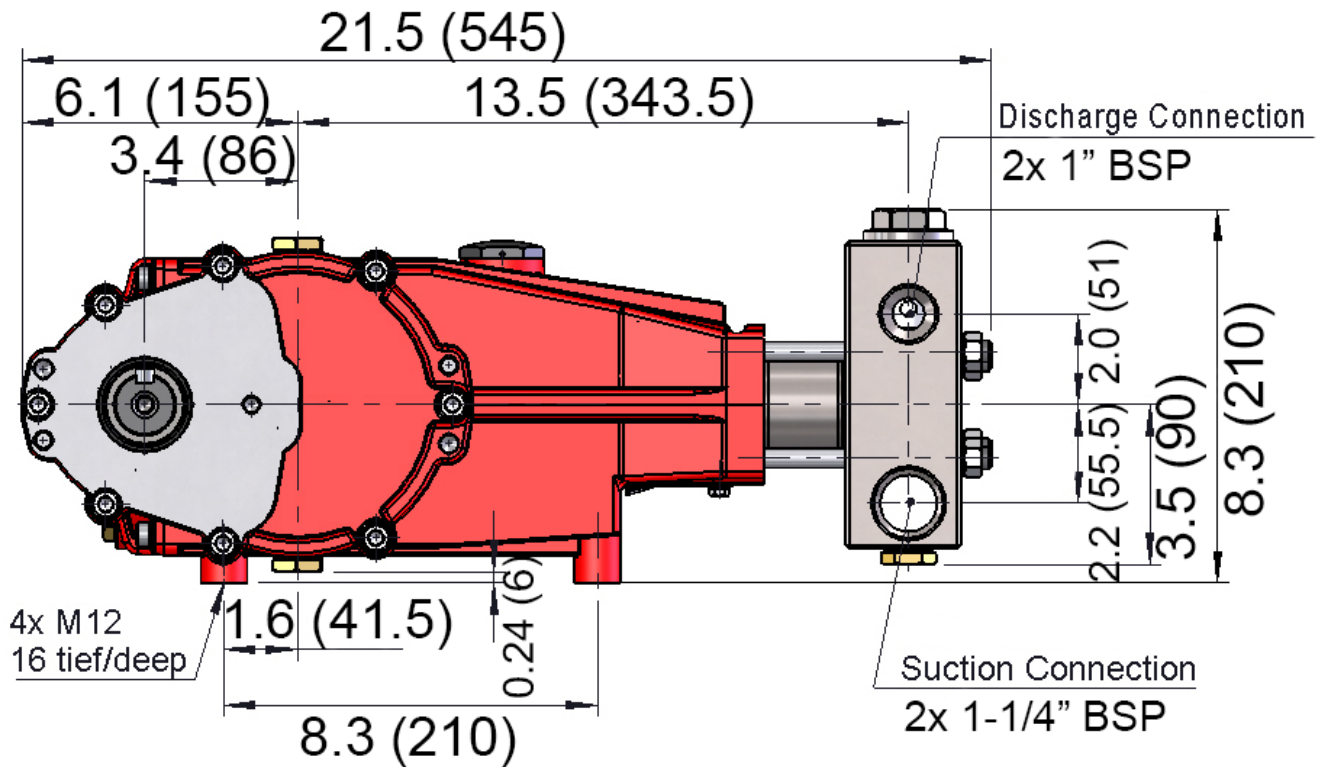
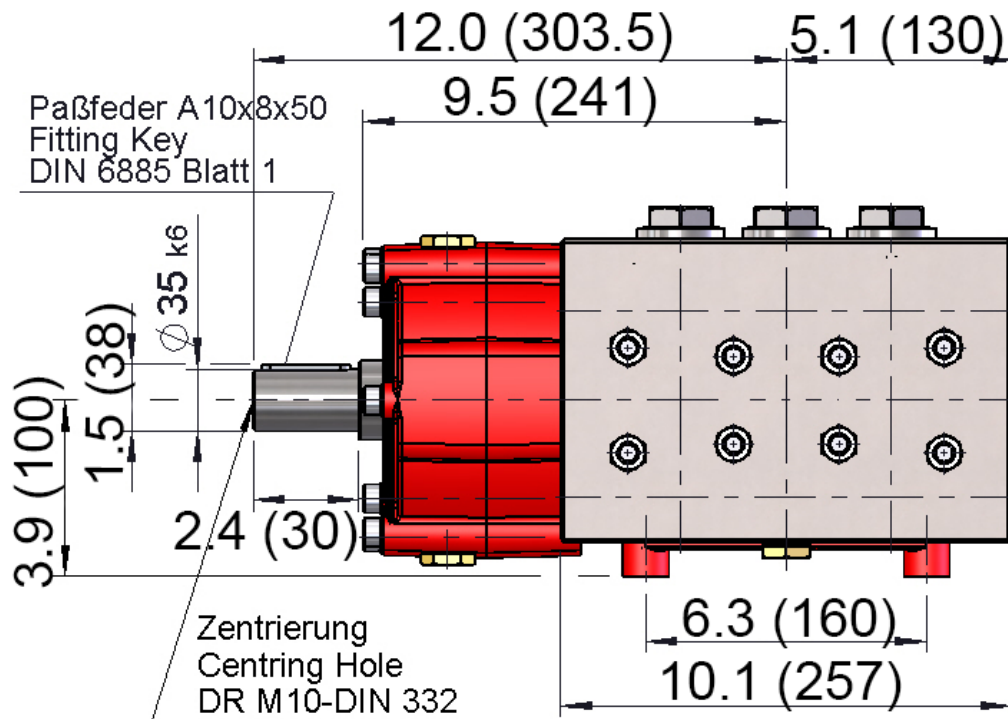

GIANT INDUSTRIES LIMITED WARRANTY

Giant Industries, Inc. pumps and accessories are warranted by the manufacturer to be free from defects in workmanship and material as follows:

1. Five (5) years from the date of shipment for all pumps used in portable pressure washers with NON-SALINE, clean water applications.
2. Two (2) years from the date of shipment for Giant pumps used in car wash applications.
3. One (1) year from the date of shipment for all other Giant industrial and consumer pumps.
4. Six (6) months from the date of shipment for all rebuilt pumps
5. Ninety (90) days from the date of shipment for all Giant accessories.

This warranty is limited to repair or replacement of pumps and accessories of which the manufacturer's evaluation shows were defective at the time of shipment by the manufacturer. The following items are NOT covered or will void the warranty:

1. Defects caused by negligence or fault of the buyer or third party.
2. Normal wear and tear to standard wear parts.
3. Use of repair parts other than those manufactured or authorized by Giant.
4. Improper use of the product as a component part.
5. Changes or modifications made by the customer or third party.
6. The operation of pumps and or accessories exceeding the specifications set forth in the Operations Manuals provided by Giant Industries, Inc.

Liability under this warranty is on all non-wear parts and limited to the replacement or repair of those products returned freight prepaid to Giant Industries which are deemed to be defective due to workmanship or failure of material. A Returned Goods Authorization (R.G.A.) number and completed warranty evaluation form is required prior to the return to Giant Industries of all products under warranty consideration. Call (419)-531-4600 or fax (419)-531-6836 to obtain an R.G.A. number.

Repair or replacement of defective products as provided is the sole and exclusive remedy provided hereunder and the MANUFACTURER SHALL NOT BE LIABLE FOR FURTHER LOSS, DAMAGES, OR EXPENSES, INCLUDING INCIDENTAL AND CONSEQUENTIAL DAMAGES DIRECTLY OR INDIRECTLY ARISING FROM THE SALE OR USE OF THIS PRODUCT.

THE LIMITED WARRANTY SET FORTH HEREIN IS IN LIEU OF ALL OTHER WARRANTIES OR REPRESENTATION, EXPRESS OR IMPLIED, INCLUDING WITHOUT LIMITATION ANY WARRANTIES OR MERCHANTABILITY OR FITNESS FOR A PARTICULAR PURPOSE AND ALL SUCH WARRANTIES ARE HEREBY DISCLAIMED AND EXCLUDED BY THE MANUFACTURER.



WARNING: This product might contain a chemical known to the State of California to cause cancer, and birth defects or other reproductive harm.

For more information go to www.P65Warnings.ca.gov

GIANT
Performance Under Pressure

GIANT INDUSTRIES, INC., 900 N. Westwood Ave. Toledo, Ohio 43607
PHONE (419) 531-4600, FAX (419) 531-6836, www.giantpumps.com
© Copyright 2023 Giant Industries, Inc.