

# Adjustable Regulator

## Models

### 22947R(H), 22948R(H), 22949R(H) & 22950R(H)

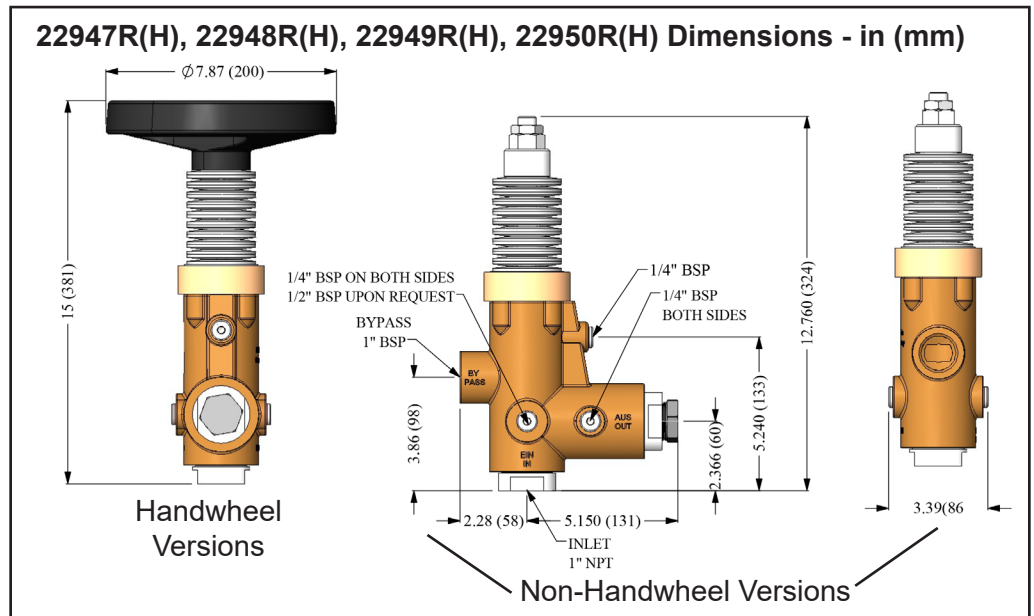
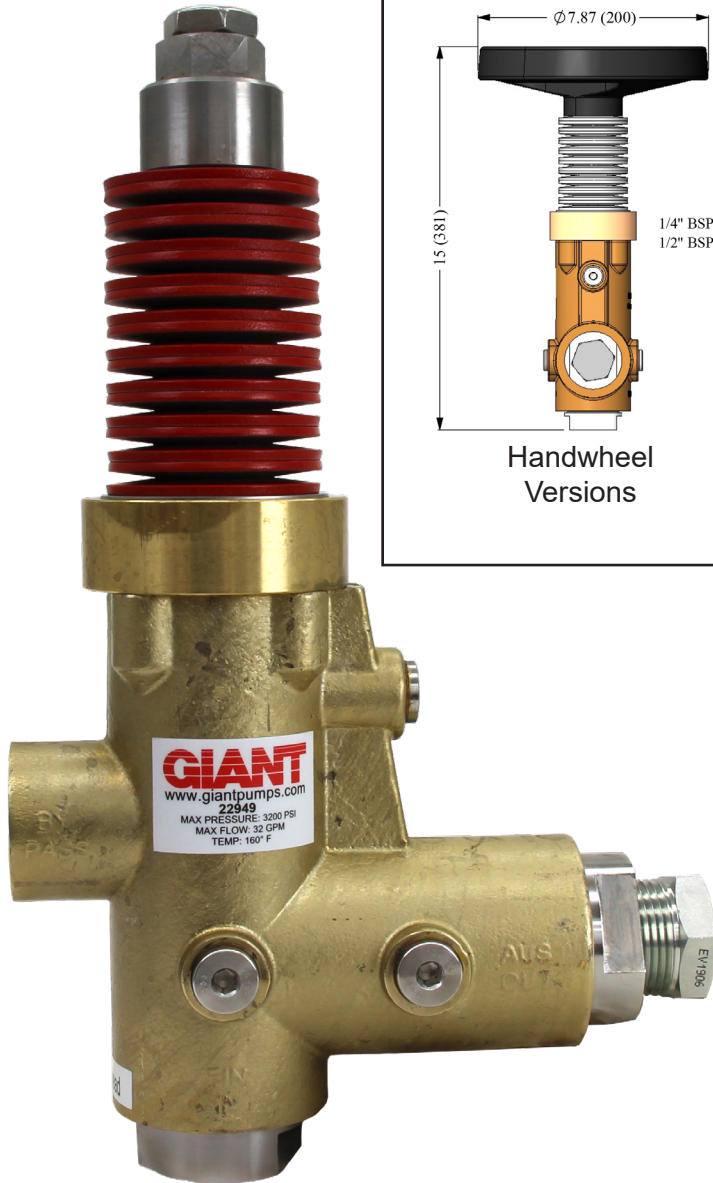

### Construction Characteristics

- Compact in size
- Interchangeable Valve Bodies
- Connection for pressure gauge, pressure switch and flow switch

non-handwheel version shown

Specifications				
Unloader	Pressure Range PSI (bar)	Maximum Flow GPM (L/min)	Minimum Flow GPM (L/min)	Maximum Temperature °F (°C)
22947(H)	300-1160 (20-80)	60 (225)	2.1 (8)	160 (70)
22948(H)	600-1600 (40-110)	60 (225)	2.1 (8)	160 (70)
22949(H)	1600-3200 (110-220)	32 (120)	2.1 (8)	160 (70)
22950(H)	3200-5800 (220-400)	16 (60)	2.1 (8)	160(70)

# 22947R, 22948R, 22949R, and 22950R Non-Handwheel Versions Cut-through View and Parts

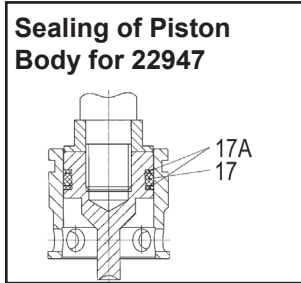
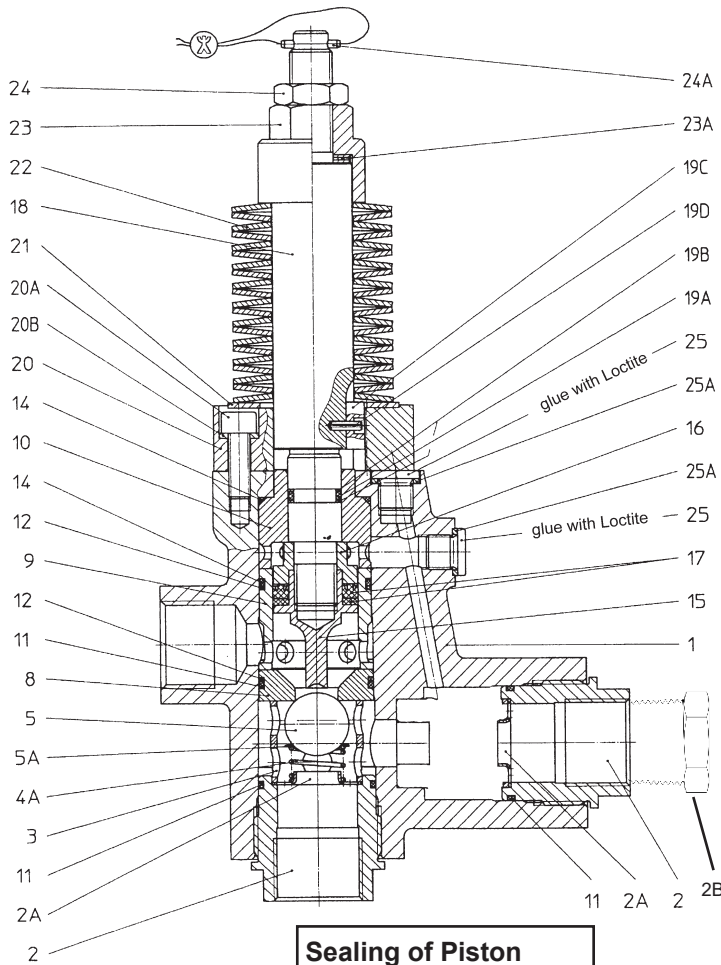

Item	Part #	Description	Qty
1	06730	Casing	1
2	12042	Tension Plug	1
2A	12043	Spring Tension Disc	1
2B	PF-5406-16PSS	Plug	1
4A	12118	Spring, Inlet valve	1
5	12046-0100	Ball Valve, Inlet (22947/22948)	1
5	12047-0100	Ball Valve, Inlet (22949/22950)	1
8	06734	Valve Seat, Inlet (22947/22948)	1
8	06745	Valve Seat, Inlet (22949)	1
8	06746	Valve Seat, Inlet (22950)	1
9	12053	Cylinder	1
10	12054	Guide	1
11	06577	O-Ring	2
12	12056	Support Ring	2
14	06736	O-Ring	2
15	12059	Piston	1
15	04846	Piston Body (22947)	1
16	12060	Spacer(22947)	1
16	12284	Spacer (22948/22949/22950)	1
17	04847	O-Ring for 15 (22947)	1
17	12283	Packing (22948/22949/22950)	1
17A	04848	Support Ring (22947)	2
18	06737	Piston Rod	1
19A	22618	O-Ring, Valve Stem	1
19B	12064	Spacer, Valve Stem	2
19C	12065	Key	1
19D	12066	Tension Sleeve	1
20	12067	Support Ring	1
20A	06738	Allen Screw	4
20B	01011-0400	Washer, Spring	4
21	12070	Disc	1
22	04850	Spring, Silver (22947)	23
22	12071	Spring, Yellow (22948)	19
22	12072	Spring, Red (22949)	19
22	12073	Spring, Orange (22950)	19
23	12074	Nut, Adjusting	1
23A+	06739	Spacer Disc, 0.2mm	1
23B+	06740	Spacer Disc, 0.5mm	2
23C+	06741	Spacer Disc, 1.0mm	2
23D+	06742	Spacer Disc, 5mm	1
24	06743	Nut, Locking	1
24A	06744	Tension Pin	1
25	07423-0100	Plug, 1/4"	6
25A	07161	Washer	6

\* May not be present. Quantity may vary.

Repair Kits		
Unloader	Kit Number	Parts included:
<b>Small Kit</b>		
22948/22949/22950	09619R	11,12,14,17,19A,19D
<b>Large Kit</b>		
22947	09813R	4A,5,11,12,14,17,17A,19A,19B,19D
22948	12081R	4A,5,11,12,14,17,19A,19B,19D
22949 & 22950	12082R	4A,5,11,12,14,17,19A,19B,19D

# 22947RH, 22948RH, 22949RH and 22950RH Handwheel Versions Cut-through View and Parts

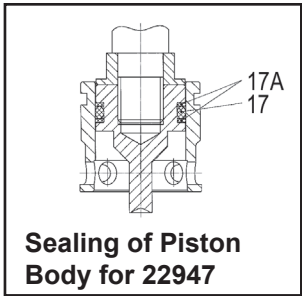
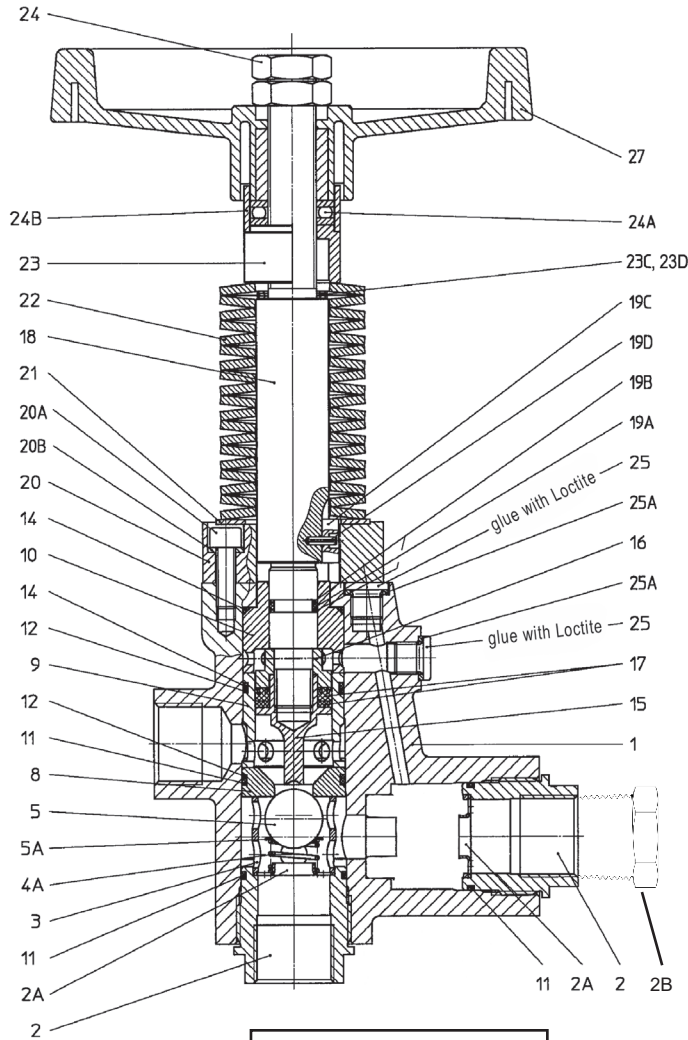

Item	Part #	Description	Quantity
1	06730	Casing	1
2	12042	Tension Plug	1
2A	12043	Spring Retainer Disc	1
2B	PF-5406-16PSS	Plug	1
4A	12118	Spring, Inlet valve	1
5	12046-0100	Ball Valve, Inlet (22947/22948)	1
5	12047-0100	Ball Valve, Inlet (22949/22950)	1
5A	05357	Spacer Disc	1
8	06734	Valve Seat, Inlet (22947/22948)	1
8	06745	Valve Seat, Inlet (22949)	1
8	06746	Valve Seat, Inlet (22950)	1
9	12053	Cylinder	1
10	12054	Guide	1
11	06577	O-Ring	2
12	12056	Support Ring	2
14	06736	O-Ring	2
15	12059	Piston	1
15	04846	Piston Body (22947)	1
16	12060	Spacer (22947)	1
16	12284	Spacer (22948/22949/22950)	1
17	04847	O-Ring for 15 (22947)	1
17	12283	Packing (22948/22949/22950)	1
17A	04848	Support Ring (22947)	2
18	04849	Piston Rod	1
19A	22618	O-Ring, Valve Stem	1
19B	12064	Spacer, Valve Stem	2
19C	12065	Key	1
19D	12066	Tension Sleeve	1
20	12067	Support Ring	1
20A	06738	Allen Screw	4
20B	01011-0400	Washer, Spring	4
21	12070	Disc	1
22	04850	Spring, Silver (22947)	23
22	12071	Spring, Yellow (22948)	19
22	12072	Spring, Red (22949)	19
22	12073	Spring, Orange (22950)	19
23	04851	Spacer Sleeve	1
23C*	04852	Spacer Disc, 1.0mm	2
23D*	04853	Spacer Disc, 5mm	1
24	04854	Nut, Locking	2
24A	04855	Tension Pin	1
24B	04856	Protective Sleeve	1
25	07423-0100	Plug, 1/4"	6
25A	07161	Washer	6
27	04857	Handwheel	1

\* May not be present. Quantity may vary.

Repair Kits		
Unloader	Kit Number	Parts included:
<b>Small Kit</b>		
22948/22949/22950	09619R	11,12,14,17,19A,19D
<b>Large Kit</b>		
22947	09813R	4A,5,11,12,14,17, 17A,19A,19B,19D
22948	12081R	4A,5,11,12,14,17, 19A,19B,19D
22949 & 22950	12082R	4A,5,11,12,14,17, 19A,19B,19D

# 22947R(H), 22948R(H), 22949R(H), 22950R(H) Operation and Maintenance

## Operation

The whole discharge must be connected via a "T" fitting to the inlet port. Should the actual operating pressure exceed the adjusted operating pressure, the valve then acts as a pressure regulator.

The valve can be operated together with several spray guns. It is also possible to connect several pumps to one common discharge line.

**IMPORTANT!** Valves are NOT SET when delivered. They become a SAFETY COMPONENT only after adjustment on the machine by trained personnel.



## Service and Adjustment

Re-servicing and adjusting work is only to be carried out by skilled tradesmen.

## Safety Instructions

**Important!** Observe direction of flow. The bypass must under no circumstances be closed or fitted with any shut-off device.

**Important!** Continuous bypass operation without releasing the water can cause the liquid to heat up which in turn could damage the unit and endanger persons.

### Possible preventive measures:

- 1.) Limit the bypass duration (max. temperature 140 °F/60 °C); the duration is to be calculated by the operator and in conjunction with the operating conditions.
- 2.) Use fittings (e.g. thermal valve on water inlet) to avoid heat increase.

### To Adjust Pressure

- 1.) Open valve so that it is completely tension-free, i. e. loosen nut (24) and adjusting nut (23) so that the piston rod can be moved by hand.
- 2.) Spring pack is tensioned by adjusting nut (23) while the pump is running and with open gun (if more than one gun is used, all have to be open) until required operating pressure is attained and no more water runs out on the bypass side. Then lock nut (24) to adjusting nut (23). If the nozzle hole corresponds exactly to the flow-rate and pressure of the pump, no more water will run out over the bypass after the required pressure has been attained.

If the nozzle hole is too small and the whole output won't go through the nozzle after the maximum pump pressure has been reached, on no account is the valve to be adjusted higher than the maximum operating pressure of the pump. In this case, the bypass should be partially left open. It is however, advisable to install suitable nozzles.

### To Renew Piston Rod Seals and Sleeves

Unscrew nuts (24+23). Remove spring pack (22). With a 6mm allen wrench, unscrew the 4 inner hexagon screws (20A) and remove spring support (20). Remove woodruff key (19C) and remove inlet tensioning plug (2). Remove spring (4A), ball (5) and spacer disc (5A). Push out piston rod (18) downwards together with inner parts (8, and 9). Remove piston body (15) with a size 19 wrench and pull piston rod out of guide case (10). Cut out worn seals and replace. Then carefully clip O-ring (19A) and support rings (19B) onto the piston rod. Note order of installation. For 22948, 22949 and 22950, put packing (17) on piston rod (18). For 22947, put o-ring (17) and support ring (17A) on piston rod (18). Re-install guide sleeve (10) and spacer (16). Check casing (1) surfaces and inner parts for dirt or damage as this will cause the seals to wear out quickly. Check O-rings (11&14) and support rings (12) and replace as necessary. Remount piston body to piston rod with Loctite 648. Re-assemble in reverse order. Grease all parts lightly with Silicone before reinstalling.

### To Check and Replace Valves

Remove the plugs (2) and check whether the balls (5) or valve plate (6) are worn out. Remove valve seats (8, 7) with clipping pliers and check surfaces for damage. Check O-rings (11) and replace as necessary.



**WARNING:** This product might contain a chemical known to the State of California to cause cancer, and birth defects or other reproductive harm.

For more information go to:  
[www.P65Warnings.ca.gov](http://www.P65Warnings.ca.gov)

**GIANT**  
 Performance Under Pressure

Giant Industries, Inc.  
 900 N. Westwood Ave.  
 Toledo, Ohio 43607  
 PHONE (419) 531-4600  
 FAX (419) 531-6836  
[www.giantpumps.com](http://www.giantpumps.com)

© Copyright 2024 Giant Industries, Inc.

Troubleshooting Guide		
Problem	Cause	Remedy
Valve switched repeatedly when gun is closed	Leaky Gun	Repair gun
	Leaky pressure pipe	Seal pressure pipe
	Leaky sleeve	Replace o-rings
	Worn out kick-back valve body	Replace kick-back valve body or o-ring or examine valve seat
	Leaky seal (12, 14)	Renew seal
Leaky piston rod	Defective o-ring/support ring	Replace piston rod seals and examine surfaces in guide plug
Leaky bypass at nominal pressure	nozzle too small, too much water	Install larger nozzle
	Worn out bypass valve	Examine and renew as necessary, ball (5) and bypass valve body (8)
Pressure Gauge shows high pressure peaks when shutting off gun	Valve set too high above operating pressure	Turn back adjusting nut (23) and hexagon nut (24) or handwheel
	Dirty valve	Clean valve (removing lime deposits, etc.) Grease parts before reinstalling