

Model P426HP Pump

Triplex Ceramic
Plunger Pump
Operating Instructions/
Repair and Service Manual

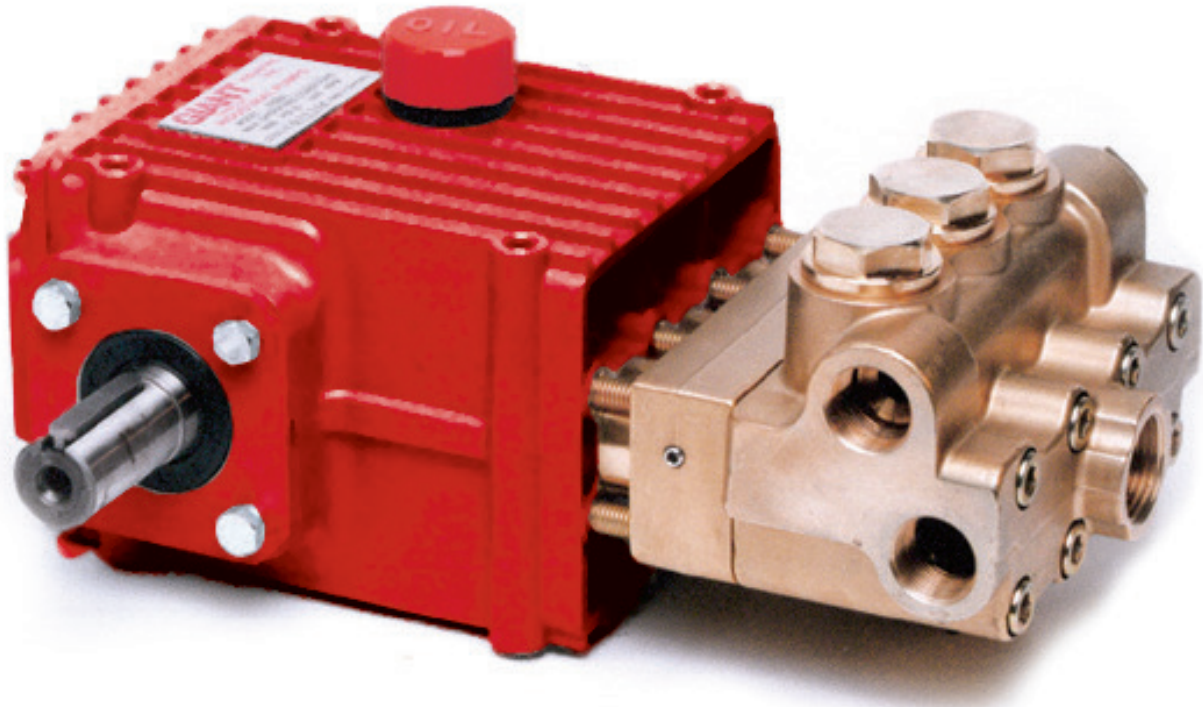

GIANT
Performance Under Pressure

Contents:

	<u>Page</u>
Installation Instructions:	2
Pump Specifications:	3
Exploded View:	4
Parts List/Kits:	5
Repair Instructions:	6-10
Torque Specifications	10
Trouble Shooting Chart:	11
Recommended Spare Parts List:	11
Dimensions:	back page
Warranty Information:	back page

INSTALLATION INSTRUCTIONS

Required NPSH refers to water (specific weight 1kg/dm³) at maximum permissible pump revolutions.

Operation and Maintenance

Check oil level prior to starting to ensure trouble-free water supply.

Important! If there is a **danger of frost**, the water in the pump and in the pump fittings (particularly the unloader valve) must be emptied. The second discharge port can also be used and the pump run "dry" for 1-2 minutes for this purpose.

Oil amount: 30.4 ounces (0.9 liters). Only use **ISO VG 220 industrial gear oil** (e.g. Aral Degol BG220) or **automobile gear oil SAE 90 GL4** (Giant p/n 01154).

Initial oil change after 50 operating hours and then every 500 hours, after 1 year if used less. Caution when operating in damp places or with high temperature fluctuations. Oil must be changed immediately should condensate (frothy oil) occur in the gear box.

NPSH values must be observed.

Maximum input pressure 145 PSI (10 bar), maximum suction head -4.35 PSI (-0.3 bar). Make sure that suction pulsation is sufficiently dampened - water column resonance must be avoided.

Important! If the pump is not used for a long period of time, it is possible the seals (23/24) could become hard or brittle thus causing the pump to leak when put into operation.

If this is the case, we recommend these seals be replaced every 4 years.

Safety Rules

A safety valve is to be installed in accordance with the guidelines for liquid spraying units so that the admissible operating pressure cannot be exceeded by more than 10%. Pump operation without a safety valve as well as any excess in temperature or speed limits automatically voids the warranty.

When the pump is in operation, the drive shaft end and the coupling must be enclosed by a protective cover or a coupling bell.

Pressure in the discharge line and pump must be at zero before any maintenance to the pump takes place. Shut off suction line. Disconnect fuses to ensure that the driving motor does not get switched on accidentally. Make sure that all parts on the pressure side of the unit are vented before starting the pump. In order to prevent air, or an air-water mixture being absorbed and to prevent cavitation occurring, the pump NPSHR (=suction head) and water temperature must be respected.

Cavitation and/or compression of gases lead to uncontrollable pressure kicks which can ruin pump and unit parts and also be dangerous to the operator or anyone standing nearby.

Giant Plunger Pumps are suitable for pumping clean water and other non-aggressive or non-abrasive media with a specific weight similar to water.

Before pumping other liquids - especially inflammable, explosive and toxic media - the pump manufacturer must be consulted with regard to the resistance of the pump material. It is the responsibility of the equipment manufacturer and/or operator to ensure that all pertinent safety regulations are adhered to.

Model P426HP Specifications

	U.S.	(Metric)
Maximum Flow.....	Up to 14.3 GPM	(54 L/min)
Maximum Discharge Pressure	Up to 3000 PSI	(200 bar)
Maximum Inlet Pressure	145 PSI	(10 bar)
Power Required	27.1 BHP.....	(20.7 kW)
Stroke	0.97"	(24.6 mm)
RPM.....		Up to 1450 RPM
Plunger Diameter.....	1.02"	(26 mm)
Temperature of Pumped Fluids.....	Up to 160 °F	(70 °C)
Inlet Ports.....		(1) 1" BSP, (2) 3/4" BSP
Discharge Ports		(2) 3/4" BSP
Shaft Rotation	Top of pulley towards fluid end	
Crankshaft Diameter.....		(28 mm)
Key Width		(8 mm)
Shaft Mounting.....		Either side ¹
Weight.....	42 lbs.	(19 kg)
Crankcase Capacity.....	30.4 fl.oz.	(0.9 liters)

Consult the factory for special requirements that must be met if the pump is to operate beyond one or more of the limits specified above.

NOTES:

In order to drive the pump from the side opposite the present shaft extension, simply remove the valve casing from the crankcase and rotate the pumps 180 degrees to the desired position. Be certain to rotate the seal case (item #20) as well, so that the weep holes are down at the six o'clock position. Exchange the oil fill and the oil drain plugs, also. Refer to the repair instructions as necessary for the proper assembly sequence.

P426HP HORSEPOWER REQUIREMENTS					
RPM	GPM	1000 PSI	1500 PSI	2000 PSI	3045 PSI
785	7.7	5.3	8.0	10.6	16.2
900	8.9	6.1	9.2	12.3	18.7
1010	10.0	6.9	10.3	13.8	21.0
1120	11.1	6.8	10.2	15.3	23.3
1240	12.2	8.4	12.6	16.8	25.6
1450	14.3	8.8	14.8	19.7	30.0

SPECIAL NOTE:

The theoretical gallons per revolution (gal/rev) is 0.00986. To find specific outputs at various RPM, use the formula: $GPM = 0.00986 \times RPM$

HORSEPOWER RATINGS:

The rating shown are the power requirements for the pump. Gas engine power outputs must be approximately twice the pump power requirements shown above.

We recommend a 1.15 service factor be specified when selecting an electric motor as the power source. To compute specific pump horsepower requirements, use the following formula:
 $HP = (GPM \times PSI) / 1450$

P426HP Pump Exploded View

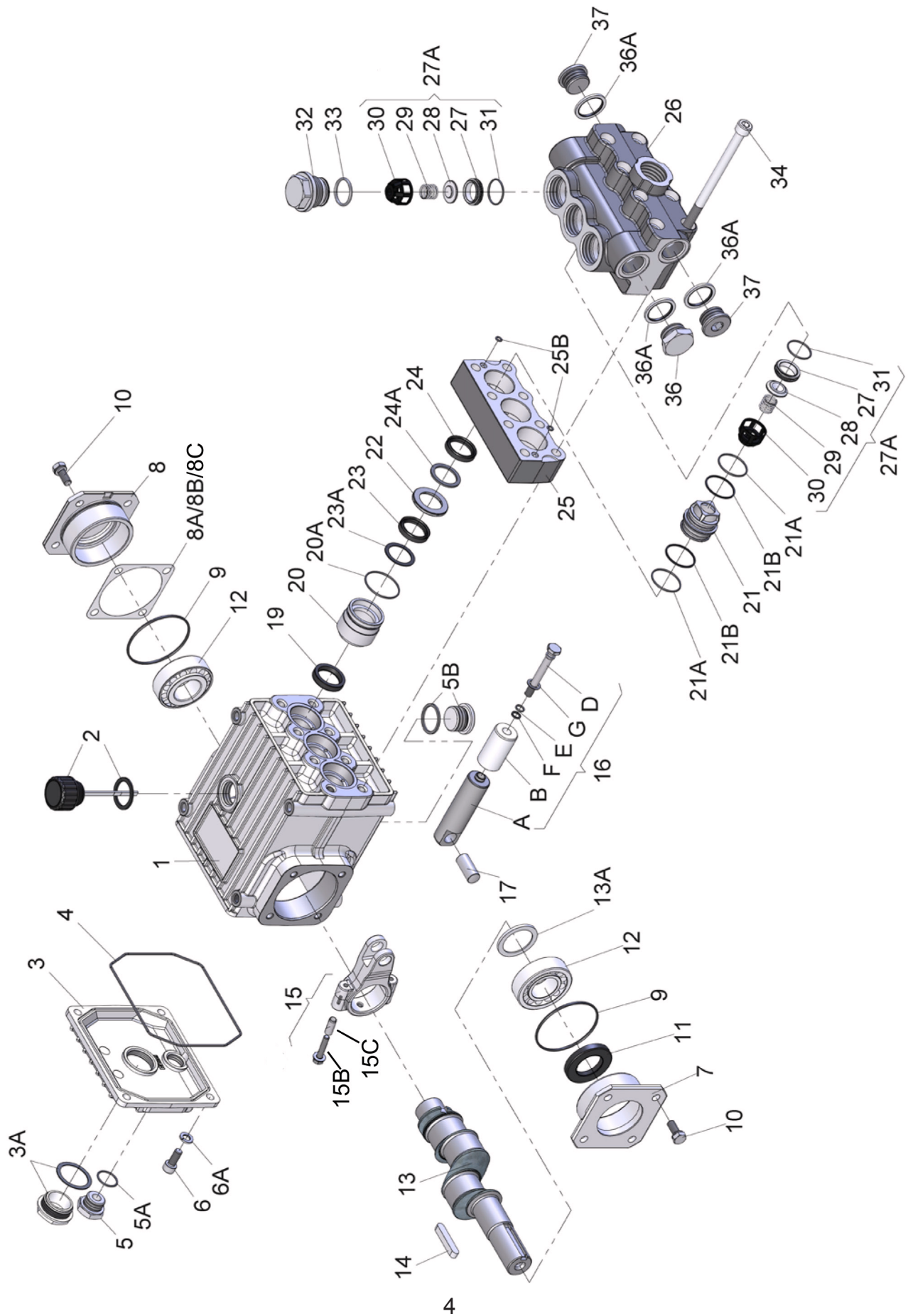

P426HP Pump Spare Parts List

<u>ITEM</u>	<u>PART</u>	<u>DESCRIPTION</u>	<u>QTY.</u>	<u>ITEM</u>	<u>PART</u>	<u>DESCRIPTION</u>	<u>QTY.</u>
1	08377	Crankcase	1	16F	07203	Backup Ring	3
2	08378	Oil Fill Plug with Gasket	1	16G	07258	Copper Washer	3
3	06479	Crankcase Cover	1	17	06790	Crosshead Pin	3
3A	07186	Oil Sight Glass w/ Gasket	1	19	05444	Oil Seal	3
4	08380	O-Ring	1	20	04654	Seal Case	3
5	07109	Oil Drain Plug, 1/2" BSP	1	20A	07266	O-Ring	3
5A	06015	O-Ring	1	21	04655	Seal Sleeve	3
5B	08092	Plug with Gasket	1	21A	07281	O-Ring	6
6	01010	Screw	4	21B	05967	Support Ring	6
6A	01011-0400	Spring Washer	4	22	04656	Drip Return Ring	3
7	04739	Bearing Cover Open	1	23	04657	Grooved Seal	3
8	05291	Bearing Cover Closed	1	23A	04658	Support Ring	3
8A	05292	Shim	1-3	24	04657	Grooved Seal	3
8B	05293	Shim	1	24A	04660	Support Ring	3
8C	05964	Shim	2	25	04661	Seal Casing	1
9	01016	O-Ring	2	25B	02009	O-Ring	2
10	07114	Screw with Washer	8	26	04662	Manifold	1
11	07459	Radial Shaft Seal	1	27A	06936	Valve Assembly (27-31)	6
12	05350	Taper Roller Bearing	2	27	06937	Valve Seat	6
13	03091	Crankshaft	1	28	06938	Valve Plate	6
14	08091	Fitting Key	1	29	06377-0100	Valve Spring	6
15	08390	Connecting Rod Assembly	3	30	06939	Valve Spring Retainer	6
15B	05349	Connecting Rod Screw	6	31	07212	O-Ring	6
15C	05348	Adapter Sleeve	6	32	05971	Plug, M33 x 1.5	3
16	03092	Plunger Assembly	3	33	05972	O-Ring	3
16A	05352	Plunger Base	3	34	05973	Cap Screw	8
16B	04653	Plunger Pipe	3	36	07703	Plug, 3/4" BSP	1
16D	08399	Tensioning Screw	3	36A	04663	Seal Ring	3
16E	07023	O-Ring	3	37	04664	Plug, 3/4" BSP	2

P426HP Pump Repair Kits

Plunger Packing Kits

09829

<u>Item</u>	<u>Part #</u>	<u>Description</u>	<u>Qty</u>
20A	07266	O-Ring	3
21A	07281	O-Ring	6
21B	05967	Support Ring	6
23	04657	Grooved Seal	3
24	04657	Grooved Seal	3
24A	04660	Support Ring	3
25B	02009	O-Ring	2

Valve Assembly Kit

09724

<u>Item</u>	<u>Part #</u>	<u>Description</u>	<u>Qty.</u>
27A	06936	Valve Assembly, Complete	6
33	05972	O-Ring	6

Oil Seal Kit

09641

<u>Item</u>	<u>Part #</u>	<u>Description</u>	<u>Qty</u>
19	05444	Oil Seal	3

P426HP Pump Repair Instructions

Note: Always take time to lubricate all metal and nonmetal parts with a light film of oil before reassembly. This step will ensure proper fit, at the same time protecting the pump nonmetal parts (i.e., the elastomers) from cutting and scoring.

1. Changing the Seals

Remove the 8 socket screws (34) (photo 1) on the valve casing (26).



Photo 1

Using a plastic hammer, tap off the valve casing (photo 2). The seal retainers (20) will remain either in the drive casing or in the seal casing (25) (photo 3).



Photo 2

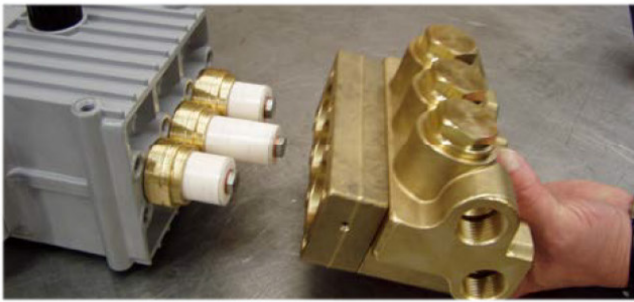

Photo 3

Carefully lever the seal casing off the valve casing by placing two screwdrivers in the seal casing side notches. Be careful not to damage casing surfaces (photo 4). The seal sleeves (21) will remain either in the seal casing (25) or in the valve casing (26) (photo 5).

Lever seal sleeves (21) out of the valve casing or respectively the seal casing (25) using two flat screwdrivers placed in the sleeve grooves (photo 6 and 7).

Then lever seal retainers (20) out of the seal casing (25) with two flat screwdrivers if necessary (photo 8).

Examine O-rings (20A/21A/25B) and support rings (21B) and replace if necessary. Cover new O-rings lightly with oil before fitting.



Photo 4



Photo 5



Photo 6



Photo 8



Photo 7

P426HP Pump Repair Instructions

Remove drip return ring (22A) and support ring (24) from seal case (photo 9).

The high pressure seal (23) in the seal casing (25) can be pushed out carefully by hand (photo 10). Drip return ring (23B) must be carefully levered out with a flat screwdriver (photo 11).

Next take support ring (24) out of seal retainer (20) (applies only to P245HP and P420HP)

Examine grooved rings (23 and 23B) and support rings (24) and replace if necessary (to fit see photo 16 and 17).

Important! Pay careful attention not to damage the surfaces in the seal casing as these are sealing surfaces.

Check plunger surfaces (16). Damaged surfaces lead to accelerated seal wear. Deposits of all kinds must be removed from the plungers.

Important! Plunger surfaces are not to be damaged. If there are lime desposits in the pump, care must be taken that the drip-return bores in parts (25) and (26) are clean and ensure trouble-free drip-return (photo 20).

When fitting the drip return seal, put in the support ring (24) first (only for P245HP and P420HP). Then make sure that the seal is fitted with its profile facing up (photo 13). Then carefully press the greased seal into its recess in the seal retainer (20) (photo 14).



Photo 9



Photo 10



Photo 11



Photo 13



Photo 15



Photo 14



Photo 16



Photo 17

To fit the high pressure seal (23), put the seal sleeves (21) into the seal casing (25) (photo 15). Place the seal casing onto the seal sleeves (21). Then put the greased seal (23) into the fitting sleeve with its **profile facing down** (photo 16) and press it into its recess in the seal casing (25) (photo 17).

P426HP Pump Repair Instructions

Lever out the O-rings (25B) (photo 18) with a small screwdriver; examine them and replace if necessary (photo 19). Coat the O-rings with silicon grease and place them in their recesses in seal casing (25).

Important! Make sure that the drip return bores in the in the seal casing and valve casing are free of lime and other deposits (photo 20).



Photo 18



Photo 19



Photo 20

Carefully put the seal retainers (20) together with the greased drip return seal (22) and support ring (24) onto the plunger (photo 21). Using a fitting sleeve, press the seal retainers (20) over the plunger and into their recess in the drive casing (photo 22 and 23). Then turn seal retainers (20) so that the $\varnothing 8$ side bore faces down (photo 23).



Photo 21



Photo 22



Photo 23

Finally push drip return ring (22A) then support ring (24) onto the plungers (photo 24 and 25).



Photo 24



Photo 25

P426HP Pump Repair Instructions

2. Checking the Valves

To check suction valves: The spring tension cap (30) of the suction valve can now be removed by carefully levering it off the valve seat (27) with a screwdriver (photo 26).



Photo 27

Examine the individual suction valve parts (photo 27 & 28) and replace if necessary. Check O-rings (31) and replace if necessary. When refitting, place the valve plate (28) on the valve seat (27); put the valve spring (29) onto the centring neck of the valve plate (photo 29).

Then place the spring tension cap (30) on top and press it down with the thumb until it clicks into the valve seat (photo 30).



Photo 29

Place the suction valve onto its recess in the valve casing (26), and press it down with the thumb until it clicks into position (Photo 31).

To check discharge valves: Screw off plugs (32) (tool size 32) (photo 32). Using a screwdriver, lever out the spring tension cap (30) (photo 33). Remove the valve parts and take out the valve seat using a size 4 (20-30 mm) extractor tool (photo 34).



Photo 32



Photo 33



Photo 34



Photo 36

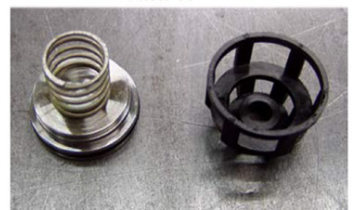

Photo 35

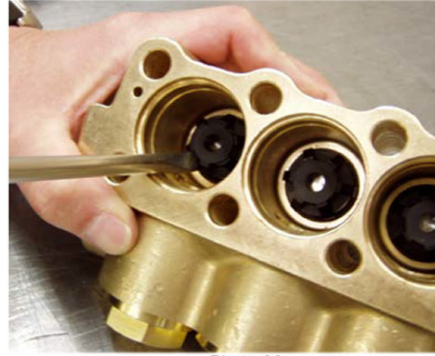

Photo 26

Then pull out the exposed valve seat (27) (photo 27) using a size 4 (20-30 mm) extractor tool (photo 28).

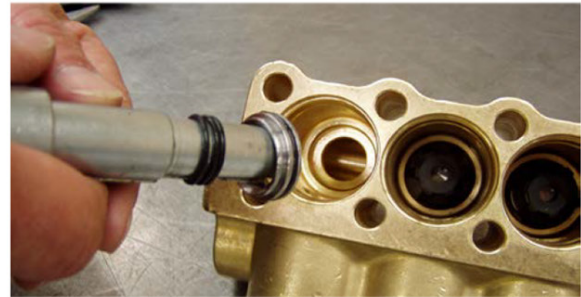

Photo 30



Photo 31

Examine the individual discharge valve parts (photo 34) and replace if necessary. When refitting, place valve plate (28) on valve seat (27); put the valve spring (29) onto the centring neck of the valve plate (photo 35).

Then place spring tension cap (30) on top and press it down with the thumb until it clicks into the valve seat (photo 36).

P426HP Pump Repair Instructions

Place the discharge valve onto its recess in the valve casing (26) and press it down with the thumb until it clicks into position (photo 37).

Screw in plugs (32) and tighten at 145 Nm (107 ft-lbs) (photo 38).



Photo 37



Photo 38



Photo 39

Now put seal casing (25) together with the mounted seal sleeves (21) onto the valve casing (26) (photo 39). Then using a plastic hammer, tap the seal casing until it lies evenly on the valve casing (photo 40).

Important! When refitting the seal casing, make sure that the greased O-rings (25B) are fitted and do not fall out during positioning (photo 18 and 20).

Push the valve casing together with the seal casing over the plungers and onto the drive (photo 41 and 42). Screw in the hexagon socket screws (34) and tighten evenly and crosswise at 40 Nm (29.5 ft-lbs) (photo 43).



Photo 40

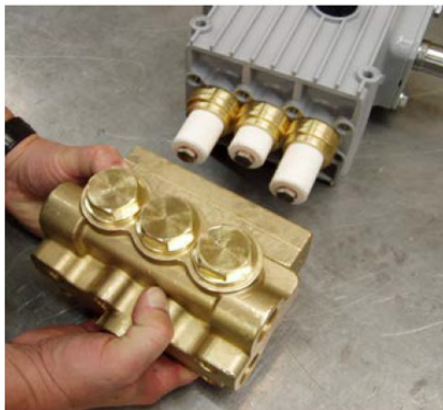

Photo 41



Photo 42



Photo 43

Torque Specifications - P426HP

<u>Item #</u>	<u>Part #</u>	<u>Description</u>	<u>Lubrication</u>	<u>U.S. (Metric)</u>
3A	07186	Oil Sight Glass w/Gasket	Loctite 5910	106 in.-lbs. (12 Nm)
5	07109	Oil Drain Plug		59 ft.-lbs. (80 Nm)
5B	08092	Plug with Gasket		59 ft.-lbs. (80 Nm)
6	01010	Screw		110 in.-lbs. (12.5 Nm)
10	07114	Screw with Washer		133 in.-lbs. (15 Nm)
15	08390	Connecting Rod Assembly		97 in.-lbs. (11 Nm)
16D	08399	Tensioning Screw	Loctite 243	21 ft.-lbs. (28 Nm)
32	05971	Plug	Loctite 243	107 ft.-lbs. (145 Nm)
34	05973	Cap Screw	Lightly oil threads	30 ft.-lbs. (40 Nm)

Contact Giant Industries for service school information. Phone: (419) 531-4600

PUMP SYSTEM MALFUNCTION

<u>MALFUNCTION</u>	<u>CAUSE</u>	<u>REMEDY</u>
The Pressure and/or the Delivery Drops	Worn packing seals Broken valve spring Belt slippage Worn or Damaged nozzle Fouled discharge valve Fouled inlet strainer Worn or Damaged hose Worn or Plugged relief valve on pump Cavitation Unloader	Replace packing seals Replace spring Tighten or Replace belt Replace nozzle Clean valve assembly Clean strainer Repair/Replace hose Clean, Reset, and Replace worn parts Check suction lines on inlet of pump for restrictions Check for proper operation
Water in crankcase	High humidity Worn seals	Reduce oil change interval Replace seals
Noisy Operation	Worn bearings Cavitation	Replace bearings, Refill crankcase oil with recommended lubricant Check inlet lines for restrictions and/or proper sizing
Rough/Pulsating Operation with Pressure Drop	Worn packing Inlet restriction Accumulator pressure Unloader Cavitation	Replace packing Check system for stoppage, air leaks, correctly sized inlet plumbing to pump Recharge/Replace accumulator Check for proper operation Check inlet lines for restrictions and/or proper size
Pressure Drop at Gun	Restricted discharge plumbing	Re-size discharge plumbing to flow rate of pump
Excessive Leakage	Worn plungers Worn packing/seals Excessive vacuum Cracked plungers Inlet pressure too high	Replace plungers Adjust or Replace packing seals Reduce suction vacuum Replace plungers Reduce inlet pressure
High Crankcase Temperature	Wrong Grade of oil Improper amount of oil in crankcase	Giant oil is recommended Adjust oil level to proper amount

Preventative Maintenance Check List & Recommended Spare Parts List						
Check	Daily	Weekly	50 hrs	Every 500 hrs	Every 1500 hrs	Every 3000 hrs
Oil Level/Quality	X					
Oil Leaks	X					
Water Leaks	X					
Belts, Pulley		X				
Plumbing		X				
Recommended Spare Parts						
Oil Change p/n 01154			X	X		
Plunger Packing Kit (1 kit/pump) (see page 5 for kit list)						X
Oil Seal Kit (1 kit/pump) (see page 5 for kit list)					X	
Valve Spare Parts (1 kit/pump) (see page 5 for kit list)						X

Dimensions - P426HP - Inches (mm)

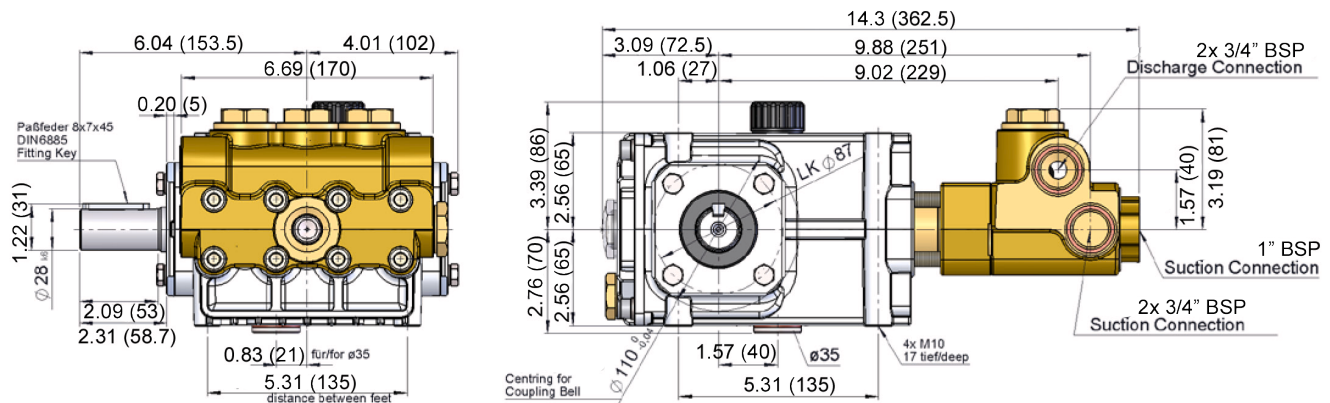

GIANT INDUSTRIES LIMITED WARRANTY

Giant Industries, Inc. pumps and accessories are warranted by the manufacturer to be free from defects in workmanship and material as follows:

1. For portable pressure washers and self-serve car wash applications, the discharge manifolds will never fail, period. If they ever fail, we will replace them free of charge. Our other pump parts, used in portable pressure washers and in car wash applications, are warranted for five years from the date of shipment for all pumps used in NON-SALINE, clean water applications.
2. One (1) year from the date of shipment for all other Giant industrial and consumer pumps.
3. Six (6) months from the date of shipment for all rebuilt pumps.
4. Ninety (90) days from the date of shipment for all Giant accessories.

This warranty is limited to repair or replacement of pumps and accessories of which the manufacturer's evaluation shows were defective at the time of shipment by the manufacturer.

The following items are NOT covered or will void the warranty:

1. Defects caused by negligence or fault of the buyer or third party.
2. Normal wear and tear to standard wear parts.
3. Use of repair parts other than those manufactured or authorized by Giant.
4. Improper use of the product as a component part.
5. Changes or modifications made by the customer or third party.
6. The operation of pumps and or accessories exceeding the specifications set forth in the Operations Manuals provided by Giant Industries, Inc.

Liability under this warranty is on all non-wear parts and limited to the replacement or repair of those products returned freight prepaid to Giant Industries which are deemed to be defective due to workmanship or failure of material. A Returned Goods Authorization (R.G.A.) number and completed warranty evaluation form is required prior to the return to Giant Industries of all products under warranty consideration. Call (419)-531-4600 or fax (419)-531-6836 to obtain an R.G.A. number.

Repair or replacement of defective products as provided is the sole and exclusive remedy provided hereunder and the MANUFACTURER SHALL NOT BE LIABLE FOR FURTHER LOSS, DAMAGES, OR EXPENSES, INCLUDING INCIDENTAL AND CONSEQUENTIAL DAMAGES DIRECTLY OR INDIRECTLY ARISING FROM THE SALE OR USE OF THIS PRODUCT.

THE LIMITED WARRANTY SET FORTH HEREIN IS IN LIEU OF ALL OTHER WARRANTIES OR REPRESENTATION, EXPRESS OR IMPLIED, INCLUDING WITHOUT LIMITATION ANY WARRANTIES OR MERCHANTABILITY OR FITNESS FOR A PARTICULAR PURPOSE AND ALL SUCH WARRANTIES ARE HEREBY DISCLAIMED AND EXCLUDED BY THE MANUFACTURER.



GIANT INDUSTRIES, INC., 900 N. Westwood Ave., Toledo, Ohio 43607
 PHONE (419) 531-4600, FAX (419) 531-6836, www.giantpumps.com
 © Copyright 2019 Giant Industries, Inc.