

K100-3 Triplex Plunger Pump



- ◆ Flow rate based on 100% volumetric efficiency and 68 °F (20 °C) ambient temperature
- ◆ Gear end with splash Lubrication
- ◆ Load-cycle-free pump head in stainless steel
- ◆ Tungsten carbide plungers
- ◆ Parts in contact with fluid stainless steel
- ◆ Horizontal installation

K 100 A Performance Data

Type	Plunger Diameter	Pump Speed	Flow		Power Required at		Power Required at		Power Required at	
					14,500 PSI	1000 bar	21,750 PSI	1500 bar	29,000 PSI	2000 bar
	mm	RPM	GPM	l/min	hp	kW	hp	kW	hp	kW
108	8.5 mm	min. 500	0.53	2	5.16	3.85	7.74	5.77	10.31	7.69
		600	0.63	2.4	6.20	4.62	9.28	6.92	12.38	9.23
		700	0.74	2.8	7.22	5.38	10.84	8.08	14.44	10.77
		800	0.85	3.2	8.25	6.15	12.38	9.23	16.51	12.31
		900	0.95	3.6	9.28	6.92	13.92	10.38	18.57	13.85
		max. 1000	1.06	4	10.31	7.69	15.48	11.54	20.12	15.00

Type	Plunger Diameter	Pump Speed	Flow		Power Required at		Power Required at	
					14,500 PSI	1000 bar	17,400 PSI	1200 bar
	mm	RPM	GPM	l/min	hp	kW	hp	kW
111	11 mm	min. 500	0.9	3.4	8.77	6.54	10.53	7.85
		600	1.08	4.1	10.57	7.88	12.69	9.46
		700	1.24	4.7	12.12	9.04	14.55	10.85
		800	1.43	5.4	13.92	10.38	16.71	12.46
		900	1.61	6.1	15.73	11.73	18.88	14.08
		max. 1000	1.8	6.8	17.54	13.08	20.12	15.00

Acceptable Fluids: Water - chemical fluids - 1000mPas - maximum 104 °F (40 °C)
 Inlet pressure: 58-116 PSI (4-8 Bar) - Depending on fluid

Accessories:
 High Pressure Manifold* 7013143 (K108A)
 7022162 (K111A)

*Includes pressure gauge and burst disc holder (burst discs are sold separately)



WARNING: This product might contain a chemical known to the State of California to cause cancer, and birth defects or other reproductive harm.
 For more information go to www.P65Warnings.ca.gov

K100-3 Triplex Plunger Pump

Pump Dimensions - mm(in)

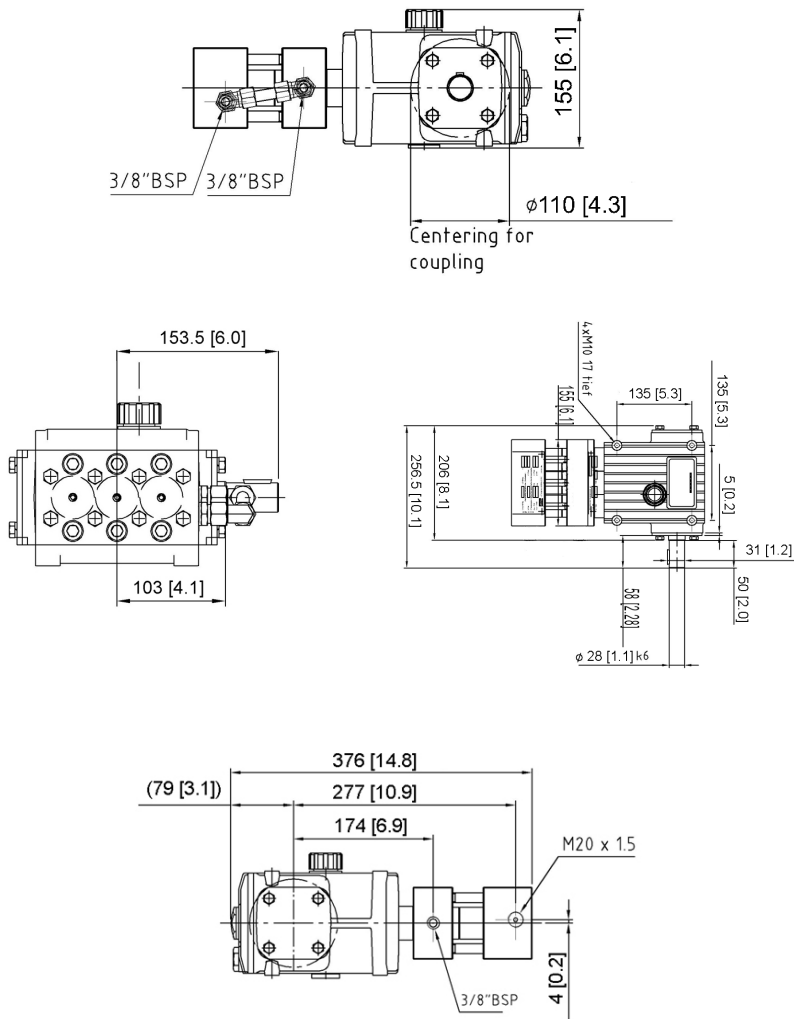

Accessories

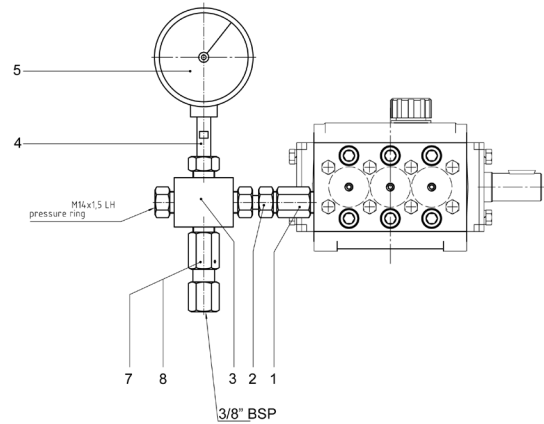

Parts List - 7013143 and 7022162

Item	Part No.	Description	Qty
1	7011856	Pipe Nipple	1
2	7011857	Coupling	1
3	7011517	T-Piece	1
4	7006375	Pipe Nipple	1
5	7014479	Pressure Gauge (7022162)	1
5	7005271	Pressure Gauge (7013143)	1
7	7013142	Burst Disc Holder	1

with electric motor 1000 rpm - 6 pole



Length	41.4 in.	1050 mm
Width	31.5 in.	800 mm
Height	35.4 in.	900 mm
Weight	552 lbs.	250 kg

with HATZ diesel engine air cooled



Length	45.3 in.	1150 mm
Width	35.4 in.	900 mm
Height	43.3 in.	1100 mm
Weight	618 lbs.	280 kg

with B&S petrol engine air cooled



Length	43.3 in.	1100 mm
Width	31.5 in.	800 mm
Height	39.4 in.	1000 mm
Weight	485 lbs.	220 kg

GIANT
Performance Under Pressure

GIANT INDUSTRIES, INC.
900 N. Westwood Ave.
Toledo, Ohio 43607

Phone: (419) 531-4600
Fax: (419) 531-6836
www.giantpumps.com

© Copyright 2022 Giant Industries, Inc.