

Model GP5124-28

Triplex Ceramic
Plunger Pump
Operating Instructions /
Manual

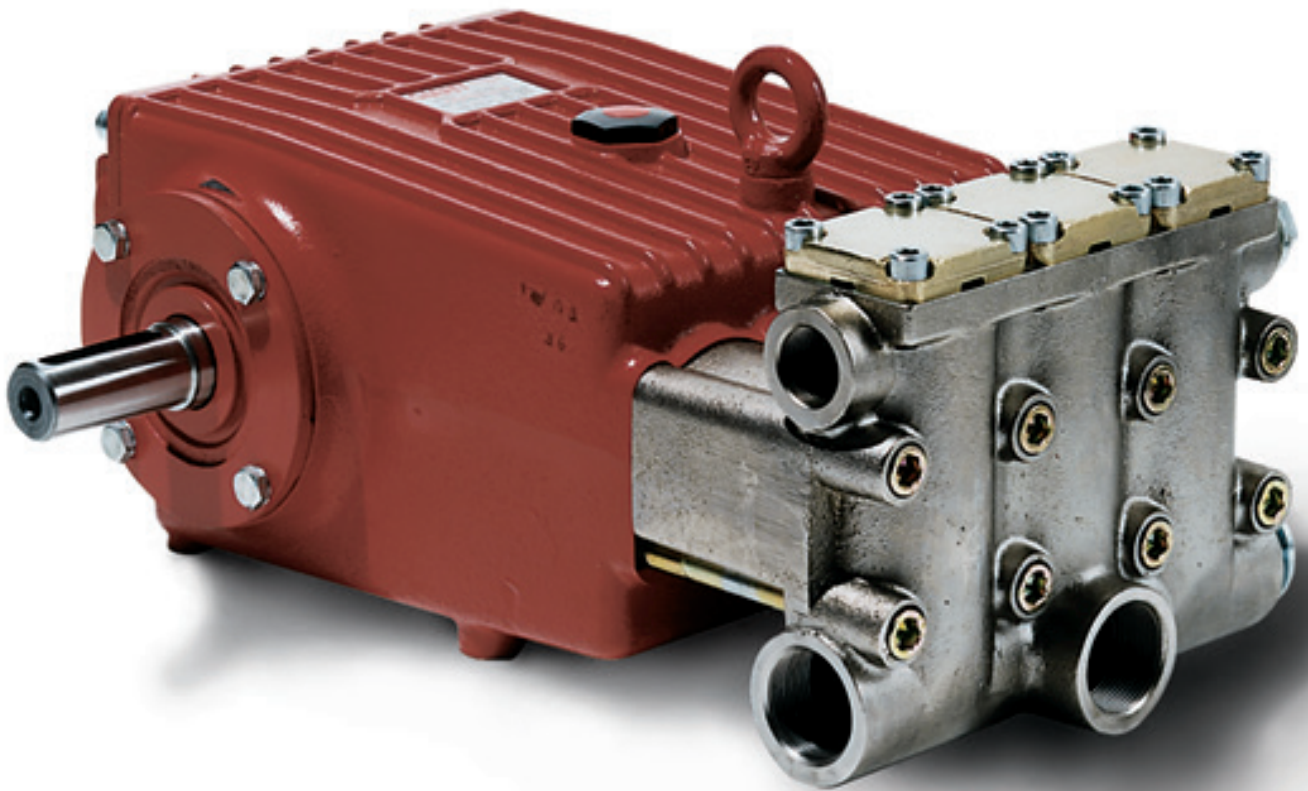

GIANT
Performance Under Pressure

Contents:	
Installation Instructions:	page 2
Pump Specifications:	page 3
Exploded View:	page 4
Parts List:	page 5
Kits/Torque Specs:	page 5
Repair Instructions:	page 6
Dimensions:	page 7
Warranty Information	back page

INSTALLATION INSTRUCTIONS

Figures for speed (rpm) and pressure apply to interval operation with cold water.

For continual operation, the speed of all pump models must be limited to 700 rpm and the max. operating pressure reduced by 10%.

Required NPSH refers to water: Specific weight 1kg/dm^3 , viscosity 1°E at max. permissible revolutions.

Operation and Maintenance

Check oil level prior to starting and ensure trouble-free water supply. Oil: Use only 1.2 gallons (4.6 liters) of Industrial Gear Lube Oil (Giant p/n 01154) or ISO VG 220 (e.g. Aral Degol BG220) or SAE 90 gear oil.

Initial change after 50 operating hours and then every 500 operating hours.

Caution when operating in damp places or with high temperature fluctuations. Oil must be changed immediately, should condensate (frothy oil) occur in the gear box.

Keep NPSH under control.

Max. input pressure 145 PSI (10 bar), max. suction head -4.35 PSI (-0.3 bar).

Safety Rules

Pump operation without safety valve as well as any excess in temperature or speed limits automatically voids the warranty. The safety valve must be regulated in accordance with the guidelines for liquid spraying units so that the admissible operating pressure can not be exceeded by more than 10%.

When the pump is in operation, the open shaft end must be covered up by a shaft protector (21), the driven shaft side and coupling by a contact-protector.

Pressure in discharge line and in pump must be at zero before any maintenance to the pump takes place. Close up suction line. Disconnect fuses to ensure that the driving motor does not get switched on accidentally.

Make sure that all parts on the pressure side of the unit are vented and refilled, with pressure at zero, before starting the pump.

In order to prevent air, or an air/water-mixture being absorbed and to prevent cavitation occurring, te pump-npshr, positive suction head and water temperature must be kept under control.

Cavitation and/or compression of gases lead to uncontrollable pressure-kicks which can ruin pump and unit parts and also be dangerous to the operator or anyone standing nearby.

Giant plunger pumps are suitable for pumping clean water and other non-aggressive or abrasive media with a specific weight similar to water.

Before pumping other liquids - especially inflammable, explosive and toxic media - the pump manufacturer must under all circumstances be consulted with regard to the resistance of the pump material. It is the responsibility of the equipment manufacturer and/or operator to ensure that all pertinent safety regulations are adhered to.

Specifications

Model GP5124-28

	U.S.	(Metric)
Volume.....	20.6 GPM	78.0 LPM
Discharge Pressure	4060 PSI	280 bar
Power Required.....	57.7 BHP	43.0 kW
Speed (Continuous).....		1400 RPM
Inlet Pressure (maximum)	-4.35 to 145 PSI	-0.3 to 10 bar
Plunger Diameter.....	0.98"	24 mm
Crankshft Stroke.....	1.81"	46 mm
Crankshaft Diameter.....	1.38"	35 mm
Crankshaft Mounting		Either side
Shaft Rotation.....		Top of pulley towards manifold
Temperature of Pumped Fluids	Up to 140°F	(60°C)
Inlet Ports		(3) 1-1/2" NPT
Discharge Ports		(2) 1" NPT
Weight	179 lbs.	(81 kg)
Crankcase Oil Capacity	1.2 Gal.	(4.6 liter)
Fluid End Material.....		Nickel-Plated Spheroidal Cast Iron

Consult the factory for special requirements that must be met if the pump is to operate beyond one or more of the limits specified above.

PULLEY INFORMATION

Pulley selection and pump speed are based on a 1725 RPM motor and "B" section belts. When selecting desired GPM, allow for a ±5% tolerance on pumps output due to variations in pulleys, belts and motors among manufacturers.

1. Select GPM required, then select appropriate motor and pump pulley from the same line.
2. The desired pressure is achieved by selecting the correct nozzle size that corresponds with the pump GPM.

HORSEPOWER INFORMATION

Horsepower ratings shown are the power requirements for the pump. Gas engine power outputs must be approximately twice the pump power requirements shown above.

We recommend that a 1.15 service factor be specified when selecting an electric motor as the power source. To compute specific pump horsepower requirements, use the following formula:

$$\text{(GPM X PSI) / 1450 = HP}$$

GP5124-28 Horsepower Requirements					
RPM	GPM	1000 PSI	2000 PSI	3000 PSI	4060 PSI
700	10.3	7.1	14.2	21.3	28.8
800	11.8	8.1	16.3	24.4	33.0
900	13.3	9.2	18.4	27.5	37.2
1000	14.7	10.1	20.3	30.4	41.2
1300	19.1	13.2	26.3	39.5	43.5
1400	20.6	14.2	28.4	42.6	57.7

GP5124-28 Exploded View

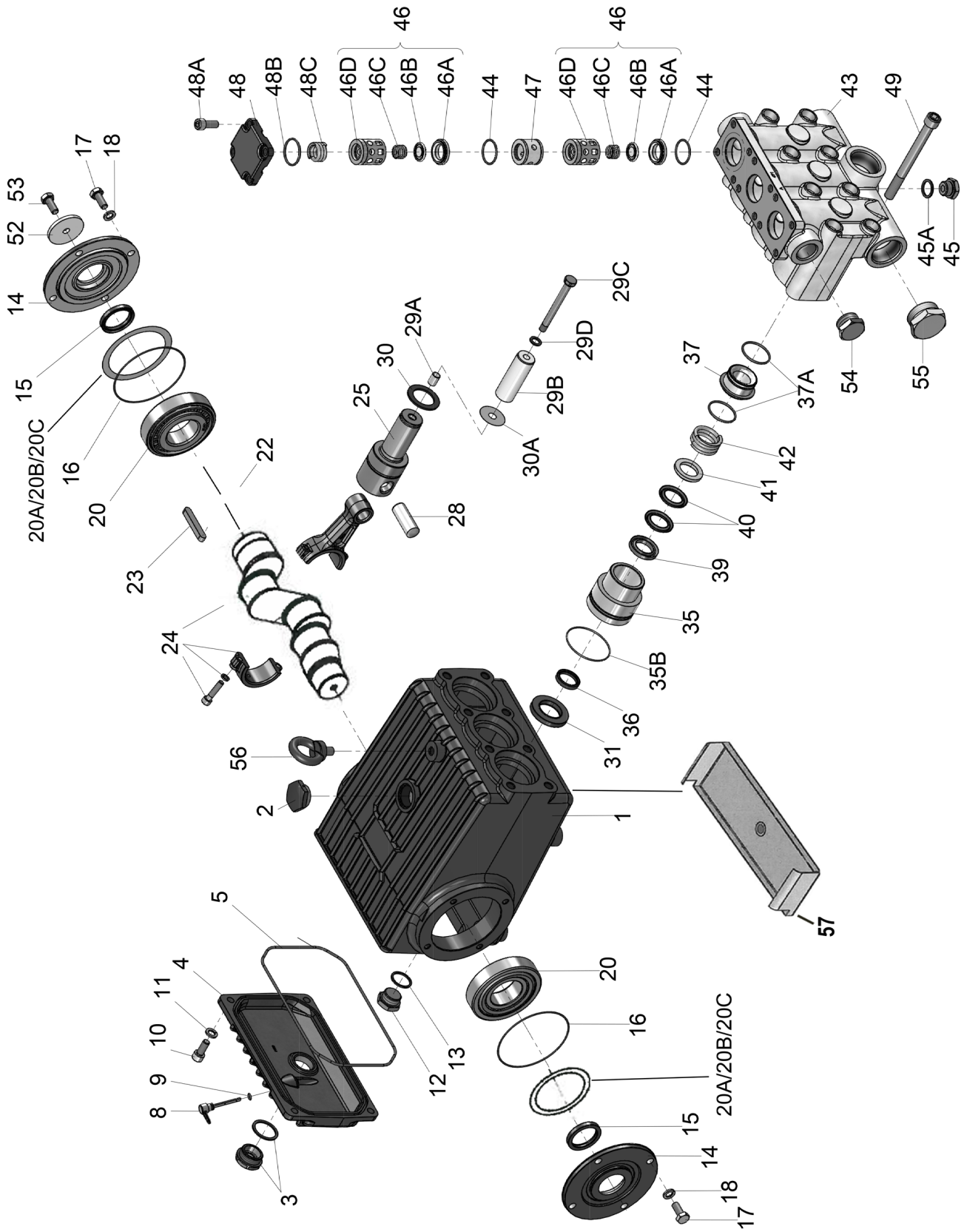

GP5124-28 Spare Parts List

<u>ITEM</u>	<u>PART</u>	<u>DESCRIPTION</u>	<u>QTY.</u>	<u>ITEM</u>	<u>PART</u>	<u>DESCRIPTION</u>	<u>QTY.</u>
1	13266	Crankcase	1	30A	05889	Washer for Drip Shield	3
2	13000	Oil Filler Plug Assembly	1	31	13284	Radial Shaft Seal	3
3	05943	Oil Sight Glass Assembly	1	35	03044	Seal Sleeve	3
4	13267	Crankcase Cover	1	35B	08183	O-Ring	3
5	13268	O-Ring	1	36	03045	Grooved Ring	3
8	07105	Oil Dip Stick	1	37	04287	Seal Case	3
9	01009	O-Ring, Dip Stick	1	37A	07700	O-Ring	6
10	07008	Inner Hexagon Screw	4	39	13366	Pressure Ring	3
11	06725	Spring Washer	4	40	06083	V-Sleeve	6
12	07703	Drain Plug, 3/4" BSP	1	41	13367	Sleeve Support Ring	3
13	07704	Gasket, Drain Plug	1	42	07338	Tension Spring	3
14	13271	Bearing Cover	2	43	04288-NPT	Valve Casing	1
15	08439	Lid	2	44	07150	O-Ring	6
16	08182	O-Ring	2	45	07109	Plug, 1/2" BSP	1
17	13358	Hexagon Screw	8	45A	06272	Copper Seal Ring, 1/2"	1
18	06725	Spring Washer	8	46	07060	Valve Assembly	6
20	13206	Taper Roller Bearing	2	46A	07064	Valve Seat	6
20A*	13207	Shim, 0.1mm	1-5	46B	07063	Valve Plate	6
20B*	04723	Shim, 0.15mm	1-5	46C	07062-0100	Valve Spring	6
20C*	04724	Shim, 0.2mm	1-5	46D	07066	Spacer Pipe	6
22	13274	Crankshaft	1	47	04295	Spacer Ring	3
23	13275	Fitting Key	1	48	04289	Plug	3
24	13276	Connecting Rod Assembly	3	48A	07008	Inner Hexagon Screw	12
25	13279	Crosshead Assembly	3	48B	13012	O-Ring	3
28	13281	Crosshead Pin	3	48C	06078	Tension Spring	3
29A	07125	Centering Sleeve	3	49	13339	Inner Hexagon Screw	8
29B	07127	Plunger Pipe	3	52	13362	Disc for Crankshaft	1
29C	13031	Tensioning Screw	3	53	13358	Hexagon Screw	1
29D	07755	Copper Ring	3	54	06626	Plug, 1" NPT	1
30	13282	Oil Scraper	3	55	06627	Plug, 1-1/2" NPT	2
				56	07623	Eye Bolt	1
				57	04334	Drip Pan	1

*May not be present

GP5128 Repair Kits

Plunger Packing Kit - #09826

<u>Item</u>	<u>Part#</u>	<u>Description</u>	<u>Qty.</u>
35B	08183	O-Ring	3
36	03045	Grooved Ring	3
37A	07700	O-Ring	6
40	06083	V-Sleeve	6

Valve Assembly Kit - #09762

<u>Item</u>	<u>Part #</u>	<u>Description</u>	<u>Qty.</u>
46	07060	Valve Assembly	6
48B	13012	O-Ring	3

Oil Seal Kit - #09230

<u>Item</u>	<u>Part #</u>	<u>Description</u>	<u>Qty.</u>
31	13284	Oil Seal	3

GP5124-28 Repair Instructions

To Check Valves

Remove inner hexagon screw (48A) and remove plugs (48) with a screwdriver. Check O-rings on plugs (48B). Pull out tension spring (48C). Take spacer pipe (46D) together with the discharge valve out of the valve casing using a clipping pliers or a $\varnothing 22$ extractor tool. Remove the next exposed spacer pipe and suction valve as already described. Remove the valve seats (46A) from the spacer pipes by lightly tapping the valve plate (46B) from above with a plastic rod. Check sealing surfaces and replace worn parts.

When reassembling, use new O-rings if possible and oil them before installing.

Tighten inner hexagon screws (48A) to 35 Ft-Lbs (47NM).

To Check Seals and Plunger Pipe

Loosen the 8 nut and pull off valve casing to the front. Pull seal sleeves (35) out of guides in crankcase and over the plunger pipe (29B). Pull support ring (41), sleeves (40) and pressure ring (39) out of seal sleeve.

Check plunger surfaces, sleeves (40) and grooved rings (36). Replace worn parts.

If the plunger pipe is worn out, loosen tension screw (29C) and pull off plunger pipe to the front. Clean contact surfaces of plunger (25) thoroughly. Then place new plunger pipe carefully through the oiled seals into the seal case. Check O-rings (35B and 37A) on seal sleeves and seal case and replace worn O-rings. Then push seal sleeve together with plunger pipe into the crankcase guide. Turn gear carefully until plunger (25) comes up against the plunger pipe. Put a new copper gasket (29D) onto the tension screw (29C). Cover the thread of tension screw and the gasket with glue and tighten to 26 Ft.-lbs. (35NM).

Important! Care must be taken that no glue gets between the plunger pipe (29B) and the centering sleeve (29A). The plunger pipe should not be strained by eccentric tightening of the tension screw or through damage to front of surface of plunger, otherwise it will probably break. Tighten the inner screws (49) for the valve casing evenly to 74-89 Ft.-Lbs. (100-120NM).

To Dismantle Gear

Drain oil after dismantling valve case and plunger pipes and screw off crankcase cover (4) and bearing cover (14).

Loosen con rod screws (24), push stem of con rod as far as possible into the crosshead guide and carefully push out the radial shaft seals (31).

Important! Connecting rods are marked for identification. Do not twist con rod halves. Con rod is to be reinstalled in the same position on shaft journals.

While slightly turning the crankshaft, hit it out carefully to one side with a rubber hammer.

Important! Do not bend con rod shank. Finally, check surfaces of shaft, con rod, crosshead and plungers (25) as well as radial shaft seals (15, 31) and taper roller bearings (20).

To Reassemble

Using a soft tool, press in the outer bearing ring until it lines up with the outer edge of the bearing hole. Remove bearing cover together with shaft ring and O-ring. Fit shaft with pressed-on bearing parts through the bearing hole on the opposite side. Press in outer bearing ring and tension it inwards with the bearing cover, keeping the shaft in vertical position and turning it slowly so that the taper rollers of the bearings touch the edge of the outer bearing ring. Adjust axial bearing clearance with fitting discs 0.1mm (20A). Shaft should turn easily with very little clearance. Tighten inner hexagon screws on con rod (24) to 26 Ft.-Lbs. (35NM).

Important! There should be enough clearance for the con rod to move sideways a little on the journals.

Important! The 1/2" BSP connection in the crankcase serves the purpose of draining leakage water. The connection should not be closed (see the drawing to the right).

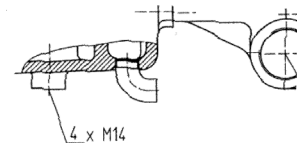

GP5124-28 Dimensions Inches (mm)

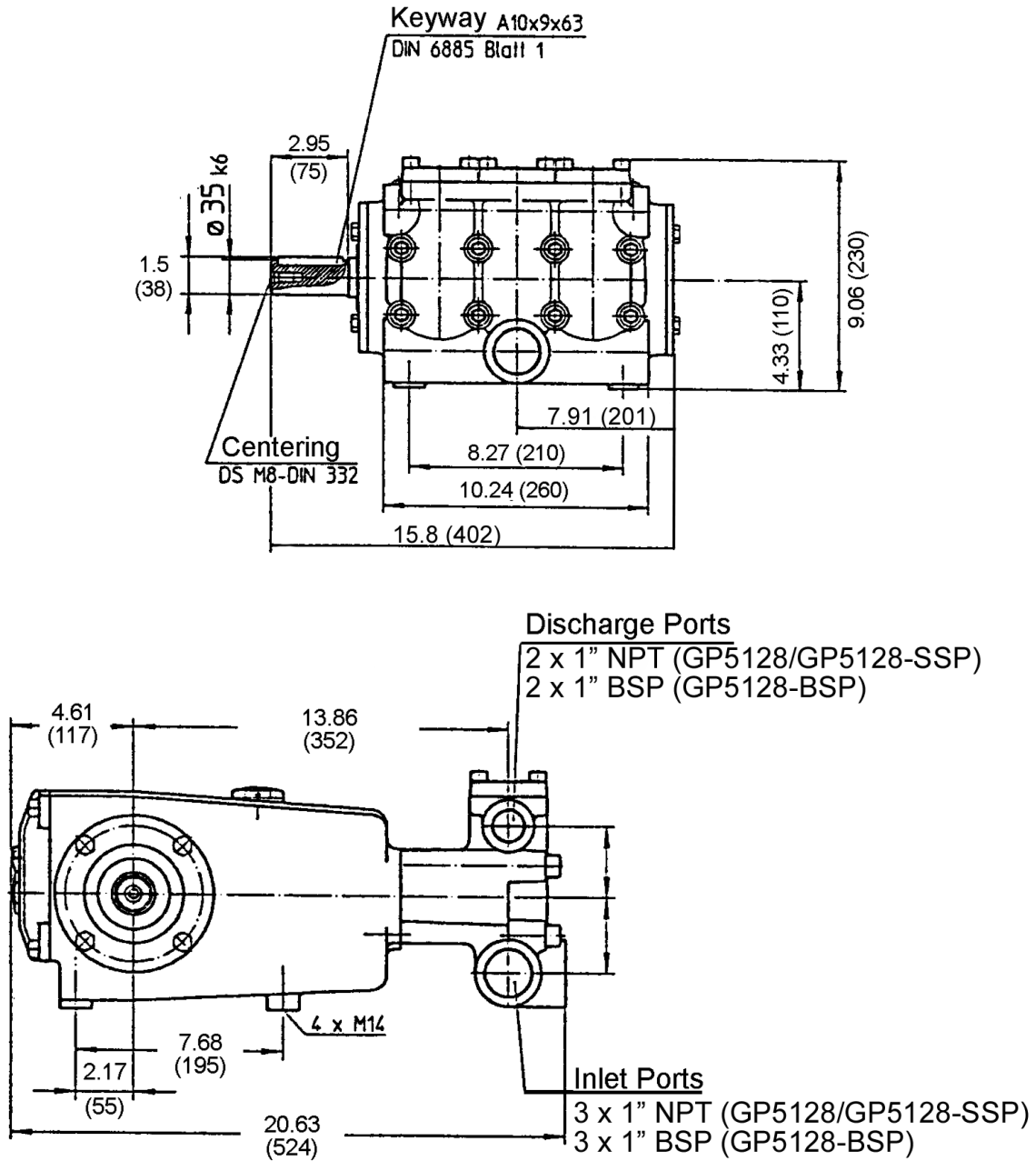

GP5124-28 Torque Specifications/Lubrication Information

<u>Position</u>	<u>Item#</u>	<u>Description</u>	<u>Lubrication</u>	<u>Torque Amount</u>
1	13266	Crankcase	Molycote Cu-Paste	
3	05943	Oil Sight Glass Assembly	Loctite 572	22 ft.-lbs. (30 Nm)
10	07008	Inner Hexagon Screw		33 ft.-lbs. (45 Nm)
12	07703	Drain Plug, 3/4" BSP		74 ft.-lbs. (100 Nm)
17	13358	Hexagon Screw		33 ft.-lbs. (45 Nm)
24	13276	Connecting Rod Assy.		22 ft.-lbs. (30 Nm)
31	13284	Radial Shaft Seal	Loctite 403	
29C	13031	Tension Screw, Plunger	Loctite 243	22 ft.-lbs. (30 Nm)
48A	07008	Inner Hexagon Screw, Plug		35 ft.-lbs. (47 Nm)
49	13339	Inner Hexagon Screw, Valve Casing		89 ft.-lbs. (120 Nm)

GIANT INDUSTRIES LIMITED WARRANTY

Giant Industries, Inc. pumps and accessories are warranted by the manufacturer to be free from defects in workmanship and material as follows:

1. Five (5) years from the date of shipment for all pumps used in portable pressure washers with NON-SALINE, clean water applications.
2. Two (2) years from the date of shipment for Giant pumps used in car wash applications.
3. One (1) year from the date of shipment for all other Giant industrial and consumer pumps.
4. Six (6) months from the date of shipment for all rebuilt pumps
5. Ninety (90) days from the date of shipment for all Giant accessories.

This warranty is limited to repair or replacement of pumps and accessories of which the manufacturer's evaluation shows were defective at the time of shipment by the manufacturer.

The following items are NOT covered or will void the warranty:

1. Defects caused by negligence or fault of the buyer or third party.
2. Normal wear and tear to standard wear parts.
3. Use of repair parts other than those manufactured or authorized by Giant.
4. Improper use of the product as a component part.
5. Changes or modifications made by the customer or third party.
6. The operation of pumps and or accessories exceeding the specifications set forth in the Operations Manuals provided by Giant Industries, Inc.

Liability under this warranty is on all non-wear parts and limited to the replacement or repair of those products returned freight prepaid to Giant Industries which are deemed to be defective due to workmanship or failure of material. A Returned Goods Authorization (R.G.A.) number and completed warranty evaluation form is required prior to the return to Giant Industries of all products under warranty consideration. Call (419)-531-4600 or fax (419)-531-6836 to obtain an R.G.A. number.

Repair or replacement of defective products as provided is the sole and exclusive remedy provided hereunder and the MANUFACTURER SHALL NOT BE LIABLE FOR FURTHER LOSS, DAMAGES, OR EXPENSES, INCLUDING INCIDENTAL AND CONSEQUENTIAL DAMAGES DIRECTLY OR INDIRECTLY ARISING FROM THE SALE OR USE OF THIS PRODUCT.

THE LIMITED WARRANTY SET FORTH HEREIN IS IN LIEU OF ALL OTHER WARRANTIES OR REPRESENTATION, EXPRESS OR IMPLIED, INCLUDING WITHOUT LIMITATION ANY WARRANTIES OR MERCHANTABILITY OR FITNESS FOR A PARTICULAR PURPOSE AND ALL SUCH WARRANTIES ARE HEREBY DISCLAIMED AND EXCLUDED BY THE MANUFACTURER.



WARNING: This product might contain a chemical known to the State of California to cause cancer, and birth defects or other reproductive harm.
For more information go to www.P65Warnings.ca.gov