

# Models 22984 22984R

# Industrial Unloader/ Regulator

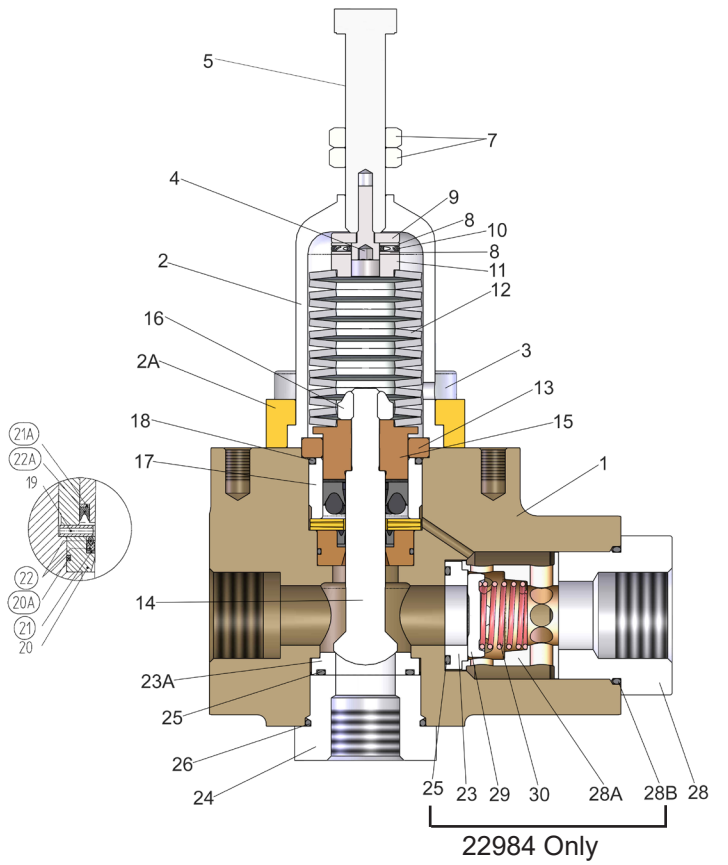

22984 = Unloader  
22984R = Regulator

## Parts List

Item	Part#	Description	Qty
1	05512	Casing	1
2	04843*	Spring Guide	1
2A	04844*	Flange for Spring Guide	1
3	07381	Inner Hexagon Screw	4
4	08503	Inner Hexagon Screw	1
5	08504	Stud Bolt	1
7	08506	Hexagon Nut	2
8	08507	Disc	2
9	08508	Bearing Part 1	1
10	12323	Axial Bearing	1
11	08510	Bearing Part 2	1
12	12220	Spring Plate	16
13	05703	Centering Disc	1
14	13247 <sup>+</sup>	Piston	1
15	05704 <sup>+</sup>	Seal Support	1
16	04036 <sup>+</sup>	Hexagon Nut	1
17	05705	Cylinder	1
18	13012 <sup>+</sup>	O-Ring	1
19	05709	Spacer Ring	1
20	05643	Seal Adapter	1
20A <sup>+</sup>	07281	O-Ring	1
21 <sup>+</sup>	07840	Support Ring	1
21A <sup>+</sup>	07904	Support Ring	1
22 <sup>+</sup>	13254	Seal Pack	1
22A <sup>+</sup>	08087	Grooved Seal Ring	1
23 <sup>+</sup>	13256	Valve Seat, 22984 Only	1
23A	03054	Bypass Valve Seat, ø25/19	1
24	05724	Bypass Valve Plug	1
25 <sup>+</sup>	12057	O-Ring, 22984 Only	2
25	12057	O-Ring, 22984R Only	1
26 <sup>+</sup>	12055	O-Ring	1
28	05725	Kick-Back Valve Plug	1
28A	13259	Spacer Pipe, 22984 Only	1
28B <sup>+</sup>	07653	O-Ring	1
29 <sup>+</sup>	13260	Valve Plate, 22984 Only	1
30 <sup>+</sup>	07750	Valve Spring, 22984 Only	1
31	07423-0100	Stop Plug (not shown)	4
32	06934	Copper Washer (not shown)	4

## Operating Specifications

Maximum Pressure:.....3000 PSI (200 bar)  
 Minimum Pressure:.....580 PSI (40 bar)  
 Maximum Flow: .....79.3 GPM (300 l/m)  
 Minimum Flow: .....2.1 GPM (8 l/m)  
 Maximum Temperature:.....160 °F (70 °C)  
 Inlet Port: .....1" FBSP  
 Outlet Port: .....1" FBSP  
 Bypass:.....3/4" FBSP  
 Weight: .....15.4 lbs. (7 kg)

The bypass line must be laid in a flow-favorable way.  
 The cross-section of the bypass line must at least correspond to the outlet cross-section of the valve.

Outlet (BSP+NPT)	1/4	1/2	3/4	1
Min. ø (mm)	8	8	15	17

<sup>+</sup> 09811 Unloader Repair Kit

<sup>^</sup> 09811R Regulator Repair Kit

\* Also sold as an assembly - p/n 06880

## 22984/22984R DIMENSIONS - INCHES (mm)

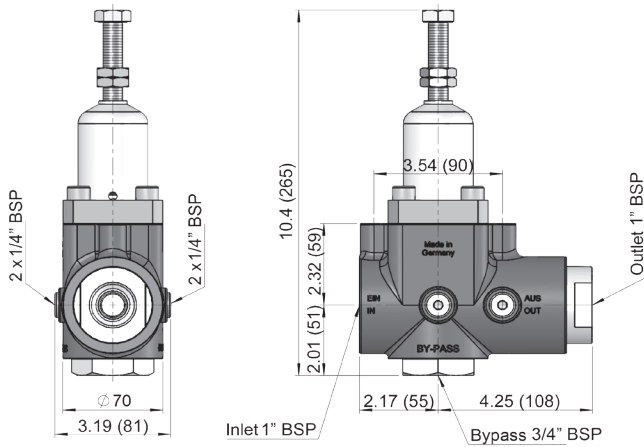

### SAFETY INSTRUCTIONS

**IMPORTANT!** Observe direction of flow. The bypass must under no circumstances be closed or fitted with any shut-off device.

**IMPORTANT!** Continuous bypass operation without releasing the water can cause the liquid to heat up which in turn could damage the unit and endanger persons.

Possible preventive measures:

1. Limit the bypass duration [maximum temperature 160 °F (70 °C)]; the duration is to be calculated by the operator and in conjunction with the operating conditions.
2. Use fittings (e.g. thermal relief valve on water inlet) to avoid head increase.

### TO ADJUST PRESSURE

The spring packing is to be pretensioned by means of the hand wheel (6) while the pump is running and the gun open (in the case of more than one gun, all guns have to be open) until required operating pressure/maximum operating pressure is reached. If adjustment of the selected nozzle sizes is correct, no water will flow through the bypass. The hexagon nut (7) is then to be locked to the spring guide (2).

**IMPORTANT!** If the nozzle hole is too small, on no account is the valve to be adjusted to an operating pressure higher than the maximum operating pressure. Suitable nozzles should be used in this case.



**WARNING:** This product might contain a chemical known to the State of California to cause cancer, and birth defects or other reproductive harm.

For more information go to [www.P65Warnings.ca.gov](http://www.P65Warnings.ca.gov)

**GIANT**  
Performance Under Pressure

**Giant Industries, Inc.**  
900 N. Westwood Ave.  
Toledo, Ohio 43607  
419-531-4600  
FAX 419-531-6836  
[www.giantpumps.com](http://www.giantpumps.com)

© Copyright 2022 Giant Industries, Inc.

## SERVICE AND ADJUSTMENT

Servicing and adjusting work is only to be carried out by a skilled tradesman.

### TO RENEW THE PISTON ROD SEALS

Relieve the spring pack by means of the hand wheel (6). Remove the four inner hexagon screws (3). Remove the spring guide (2) and flange (2A) along with the spring plates (12) and hand wheel.

**IMPORTANT!** The hexagon nuts (7) are not to be shifted from the set position. These are locking nuts which ensure that the maximum adjusting can not be exceeded. Note the sequence of the spring plates (12) for reassembling.

Push out complete piston assembly (13-22A) upwards. Hold piston (14) with a wrench and remove hexagon nut (16). Take off cylinder (17), seal support (15), centring disc (13), spacer ring (19) and seal retainer (20) together with the seals from the piston (14). Take note of the sequence for reassembling.

Check inner cylinder surface (17) and piston surface (14). Check seals and replace as necessary.

Grease all parts lightly with silicone before reinstalling.

Tighten hexagon nut (16) to 33 ft.-lbs. (45 Nm).

Center bypass valve seat (23) within casing and tighten to 111 ft.-lbs. (150 Nm) with valve plug (24). Thereafter, insert complete piston unit from the above side. Fit spring guide (2) and Flange (2A) along with spring plates (12), tighten inner hexagon screws (3) at 36 ft.-lbs. (49 Nm).

### TO CHECK AND REPLACE VALVES

Remove plugs (24 or 28), pull out spacer pipe (28A) underneath plug (24 or 28). Check whether the valve plate (29) underneath or the piston (14) are worn out.

Remove the valve seats (23) and check sealing surfaces and o-rings for damage.

Replace as necessary.

Defect	Cause	Remedy
Valve switches repeatedly when gun is closed	Leaky gun	Repair gun
	Leaky pressure pipe	Seal pressure pipe
	Leaky seal pack (22)	Renew seal pack
	Worn out valve plate (29)	Check and replace as valve plate (23), and seat (23).
	Leaky O-Ring (18).	Renew O-Ring (18).
Pressure gauge shows high-pressure above operating (6). peaks when shutting off gun.	Valve set too high pressure.	Turn back hand wheel
	Dirty valve.	Clean valve (removing deposits etc.). Grease parts before reinstalling.