

Models

22981-LF

22981R-LF

Low Friction Industrial Unloader/Regulator (High Flow)

22981-LF = Unloader
22981R-LF = Regulator

Item	Part #	Description	Qty.
1	13245	Casing	1
2*	04843	Spring Guide	1
2A*	04844	Flange for Spring Guide	1
3	07381	Inner Hexagon Screw	4
4	08503	Inner Hexagon Screw	1
5	08504	Stud Bolt	1
6	08505	Hand Wheel	1
7	08506	Hexagon Nut	3
7A	08882	Disc	2
8	08507	Disc	2
9	08508	Bearing Cover	1
10	12323	Axial Bearing	1
11	08510	Bearing Cover	1
12	12220	Spring Plate	16
13	13246	Centering Disc	1
14 ^{+o}	13247	Piston	1
15 ^{+o}	03057	Seal Support	1
16 ^{+o}	04036	Hexagon Nut	1
17	13249	Cylinder	1
18 ^{+o}	13012	O-Ring	1
19	13250	Spacer Ring	1
20	13251	Seal Adapter	1
20A ^{+o}	07281	O-Ring	1
21 ^{+o}	07840	Support Ring	2
21A ^{+o}	03058	Guide Ring	1
22 ^{+o}	03059	O-Ring	1
22A ^{+o}	03060	O-Ring	1
23 ^{+o}	13256	Valve Seat, 22981-LF	2
23 ^{+o}	13256	Valve Seat, 22981R-LF	1
24	13257	Bypass Valve Plug	1
25 ^{+o}	12057	O-Ring, 22981-LF	2
25 ^{+o}	12057	O-Ring, 22981R-LF	1
26 ^{+o}	12055	O-Ring	1
28	13258	Kick-Back Valve Plug	1
28A	13259	Spacer Pipe	1
28B ^{+o}	07653	O-Ring	1
29 ⁺	13260	Valve Plate, 22981-LF	1
30 ⁺	07750	Valve Spring, 22981-LF	1
31	07423-0100	Stop Plug (not shown)	4
32	06934	Copper Washer (not shown)	4
+	09578-LF	Unloader Repair Kit	
o	09750-LF	Regulator Repair Kit	

*Also sold as assembly - 06880

Operating Specifications

	U.S.	Metric
Max. Pressure:	2200 PSI	(150 bar)
Min. Pressure:	580 PSI	(40 bar)
Maximum Flow:	79.3 GPM	(300 l/min.)
Minimum:	2.1 GPM	(8.0 l/min.)
Maximum Temperature:	160° F	70° C
Inlet Port:		1" BSP
Outlet Port:		1" BSP
Bypass:		3/4" BSP
Weight:	15.4 lbs.	(7kg)

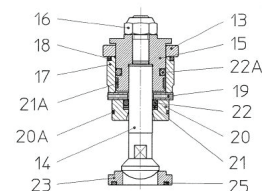
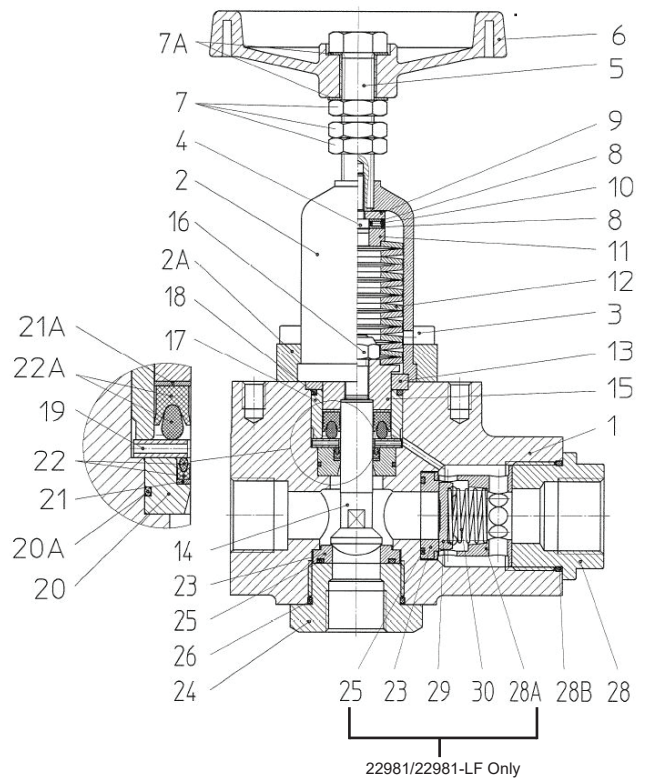

Piston Unit

SAFETY INSTRUCTIONS

IMPORTANT! Observe direction of flow. The bypass must under no circumstances be closed or fitted with any shut-off device.

IMPORTANT! Continuous bypass operation without releasing the water can cause the liquid to heat up which in turn could damage the unit and endanger persons.

Possible preventive measures:

1. Limit the bypass duration (maximum temperature 160 °F [70 °C]); the duration is to be calculated by the operator and in conjunction with the operating conditions.
2. Use fittings (e.g. thermal relief valve on water inlet) to avoid heat increase.

SERVICE AND ADJUSTMENT

Servicing and adjusting work is only to be carried out by a skilled tradesman.

TO RENEW THE PISTON ROD SEALS AND SLEEVES

Relieve the spring pack by means of the hand wheel (6). Screw out the four inner hexagon screws (3). Remove the spring guide (2) along with the spring plates (12) and hand wheel. **CAUTION: The hexagon nuts (7) are not to be shifted from the set position. These are the locking nuts to retain the maximum adjusting pressure.** Note the sequence of the spring plates (12) for reassembling. Push out complete piston assembly (13-22A) over the bypass. Hold piston (14) with size 12 wrench and remove hexagon nut (16). Take off cylinder, seal support (15), centering disc (13), spacer ring (19) and seal retainer (20) together with seals from piston (14). Take note of the sequence for reassembling.

Check inner cylinder surface (17) and piston surface (14). Check seals and replace as necessary. Dirt or damage will cause seals to wear out quickly.

Grease all parts lightly with silicone before reinstalling. Tighten hexagon nut (16) to 33 ft.-lbs. (45 Nm).

Center bypass valve seat (23) within casing and tighten to 111 ft.-lbs. (150 Nm) with valve plug (24). Thereafter, insert complete piston unit from the above side. Fit spring guide (2) and flange (2A) along with plate springs (12), tighten inner hexagon screws (3) at 36 ft.-lbs. (49 Nm).

TO CHECK AND REPLACE VALVES

Remove plugs (24 or 28), pull out spacer pipe (28A) underneath plug (24 or 28). Check whether the valve plate (29) underneath or the piston (14) are worn out. Remove valve seats (23) and check sealing surfaces and o-rings for damage. Replace as necessary.

TO ADJUST PRESSURE

The spring packing is pre-tensioned by means of the hand wheel (6) while the pump is running and the gun is open (in the case of more than one gun, all guns have to be open) until required operating pressure is reached. If adjustment of the selected nozzle sizes is correct, no water will flow through the bypass. The hexagon nut (7) is then to be locked to the spring guide (2).

IMPORTANT! If the nozzle hole is too small, on no account is the valve to be adjusted to an operating pressure higher than that of the pump. It is advisable in this case to install nozzles more suitable for this purpose.

22981/22981R DIMENSIONS - INCHES (mm)

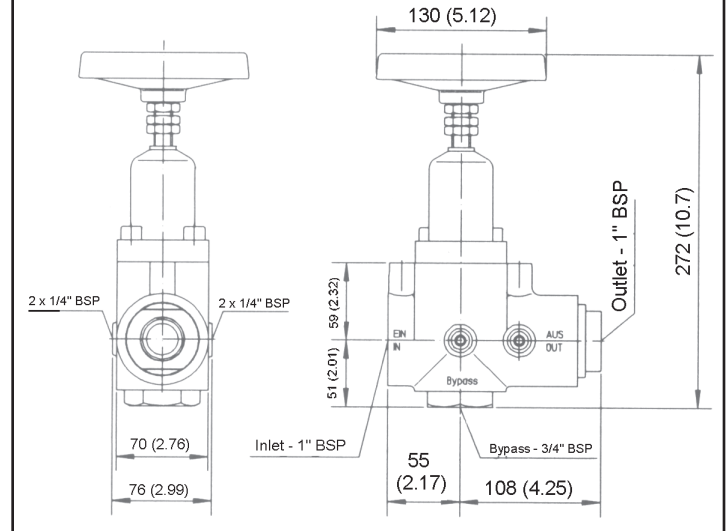

Defect	Cause	Remedy
Valve switches repeatedly when gun is closed	Leaky gun	Repair gun
	Leaky pressure pipe	Seal pressure pipe
	Leaky seal pack (22)	Renew seal pack
Pressure gauge shows high-pressure peaks when shutting off gun.	Worn out valve plate (29)	Check and replace as valve plate (23), and seat (23).
	Leaky O-Ring (18).	Renew O-Ring (18).
Valve set too high above operating pressure.	Valve set too high above operating pressure.	Turn back handwheel (6).
	Dirty valve.	Clean valve (removing deposits etc.). Grease parts before reinstalling.



WARNING: This product might contain a chemical known to the State of California to cause cancer, and birth defects or other reproductive harm. For more information go to www.P65Warnings.ca.gov

GIANT
Performance Under Pressure

Giant Industries, Inc.
900 N. Westwood Ave.
Toledo, Ohio 43607
419-531-4600
419-531-6836
www.giantpumps.com

© Copyright 2023 Giant Industries, Inc.