

Model 22235

Regulator/Relief Valve

Operating Conditions

	U.S.....	Metric
Flow:	10.6 GPM	40 L/min
Pressure Range:	510 - 4500 PSI	35-350 Bar
Max. Pressure:	5100 PSI	350 Bar
Max. Temperature*:	195 °F	90 °C
Inlet Port:	3/8 " FBSP	
Bypass:	3/8 " FBSP	
Weight:	0.84 lbs.	350 Grams

* This valve is designed for continuous duty at 140 °F (60 °C). Higher temperatures are permissible on an intermittent basis.

Note: Always remember to generously lubricate all moving parts with a light weight oil for easy reassembly and to give the moving parts protection when "running in" the unloader.

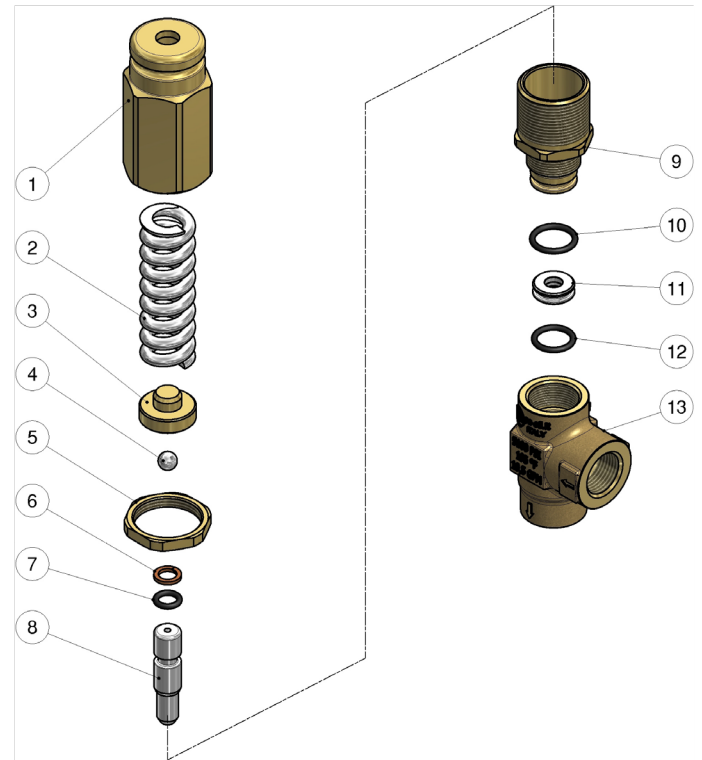

Dimensions mm (inches)

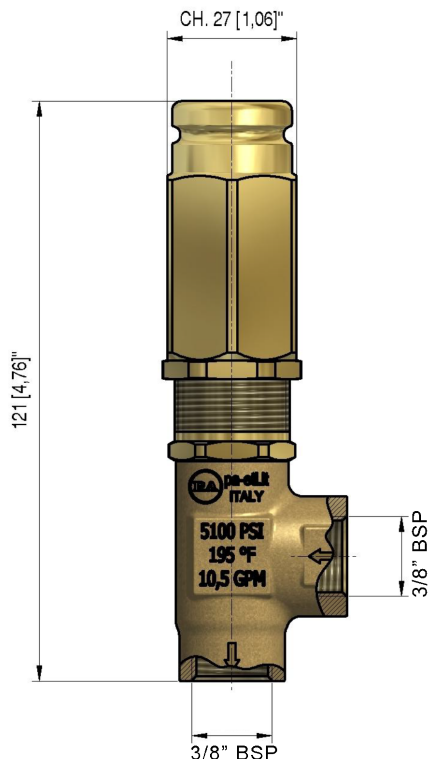

Item	Part#	Description	Quantity
1	14012	Adjusting Knob	1
2	04970	Spring	1
3	04971	Spring Guide Spacer	1
4	04738	Ball	1
5	14011	Lock Nut	1
6	04972	Backup Ring	1
7	14014	O-Ring	1
8	04973	Piston	1
9	04974	Spring Coupling	1
10	08754	O-Ring	1
11	04710	Seat	1
12	04709	O-Ring	1
13	04975	Housing	1

Repair Kit # 09782

Includes items: 6, 7, 10, 11 and 12

Instructions

This product is to be utilized with clean fresh water (possibly with some normal detergents). More corrosive liquids should not be used with this valve. The valve should be used at nominal ratings of flow and pressure. The system should not exceed the permissible pressure rating, which is imprinted on the housing (4). When used as a pressure regulator, use a nozzle that flows a bypass of at least 5% of the total flow. Please note that a worn nozzle causes pressure loss. When assembled onto a system with the above parameters, pressure spikes should be diminished (when the system is running).

Installation

When used with a hot water system, this valve should be upstream from the hot water source.

As a RELIEF VALVE, (often used in combination with unloader valves that allow low pressure on the pump manifold), this valve should be placed in an area that remains pressurized when the gun is shut-off.

As a PRESSURE REGULATOR, the valve maintains the pressure in the system (even during flow changes). In this condition, always, use a suitable safety valve. If the bypass is directed back to a tank or directly into the pump, then it is necessary to provide devices that are capable of preventing turbulence to the liquid flow.

Operation

The valve inlet is on the side; the discharge is opposite to the regulating nut (12). The discharge should be returned to a baffled tank. If the pump is fed directly from a water main, it is advisable to install a pressure reducing valve (before the pump). If the valve is operated with a lot of bypass back to the inlet of the pump, Giant recommends using a thermal relief valve (p/n 23422A) to avoid dangerous water temperature increases.

Pressure Adjustment/Setting

As a RELIEF VALVE, the adjustment has to be made in such a way that the pressure setting is not higher than the systems's working pressure and its accessories. This prevents the occurrence of numerous pressure spikes in hot water systems and high static pressure (when the gun is shut off).

As a PRESSURE REGULATOR, adjust the valve when the system is pressureized and the gun is open. If the proper nozzle is chosen, the operation should be easy and smooth. As the adjusting nut (12) is turned, there should be a corresponding change in pressure. If you are trying to increase the pressure and turning the adjusting nut clockwise, but you don't see an increase in pressure, **do not continue** to turn the adjusting nut clockwise. Make sure that the correct nozzle is being used (in relation to the flow and pressure desired). Once the desired pressure is reached, tighten the ring nut (5) against the adjusting nut. If you want, you can "set" the pressure and mark it with paint, so that you know if this has been changed.

Maintenance

This should be performed by a qualified technician. Every 400 hours (roughly 10,000 cycles), check and lubricate the seals with water resistant grease. Every 800 hours (roughly 20,000 cycles), check the seals and internal parts. If necessary, replace them with new parts.

Troubleshooting Guide		
Problem	Cause	Remedy
Valve Cycles	Air Inside the system	Flush out
	Worn out seals	Replace
	Clogged circuit	Clean or widen passages
The valve does not reach pressure	Wrong nozzle size	Modify
	Seat/Shutter/Ball worn out	Replace
	Damaged nozzle	Replace
	Impurities	Clean
Pressure Drop	Worn out nozzle	Replace
	Pump seals worn out	Replace
	Valve seat worn out	Replace
	Air inside the system	Flush out
Pressure Spikes	There is not a minimum of 5% of total flow in bypass	Readjust
	Clogged nozzle	Clean and repeat adjustment, replace nozzle
Water Leakage from Bypass - Valve pounding	O-Ring seat damaged	Replace
	Damaged Seat	Replace
	Impurities or worn out pump valves	Clean and replace