

# Model 22230

# Pressure Actuated Unloader

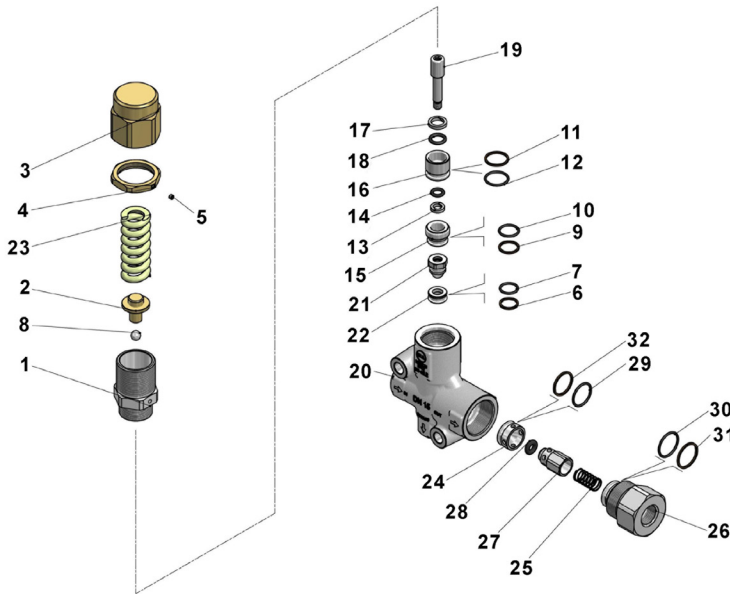

## Parts List

Item	Part#	Description	Quantity
1	04984	Piston Holder	1
2	04985	Spring Rest Pin	1
3	04986	Adjusting Knob	1
4	04987	Lock Nut	1
5	08557	Set Screw	1
6	04988	Back-up Ring	1
7	04332	O-Ring	1
8	08624	Ball	1
9	04989	Back-up Ring	1
10	08573	O-Ring	1
11	04990	Back-up Ring	1
12	08564	O-Ring	1
13	04991	Back-up Ring	1
14	04992	O-Ring	1
15	04993	Lower Spacer Ring	1
16	04994	Upper Spacer Ring	1
17	04995	Back-up Ring	1
18	04996	O-Ring	1
19	04997	Piston	1
20	04998	Housing	1
21	04999	Shutter Pin	1
22	03017	Seat	1
23	08782	Spring	1
24	03018	Seat	1
25	03019	Spring	1
26	03020	Discharge Fitting	1
27	03021	Pin	1
28	03022	O-Ring	1
29	08719	O-Ring	1
30	05909	O-Ring	1
31	03025	Back-up Ring	1
32	03024	Back-up Ring	1

Dimensional Drawing - mm (Inches)

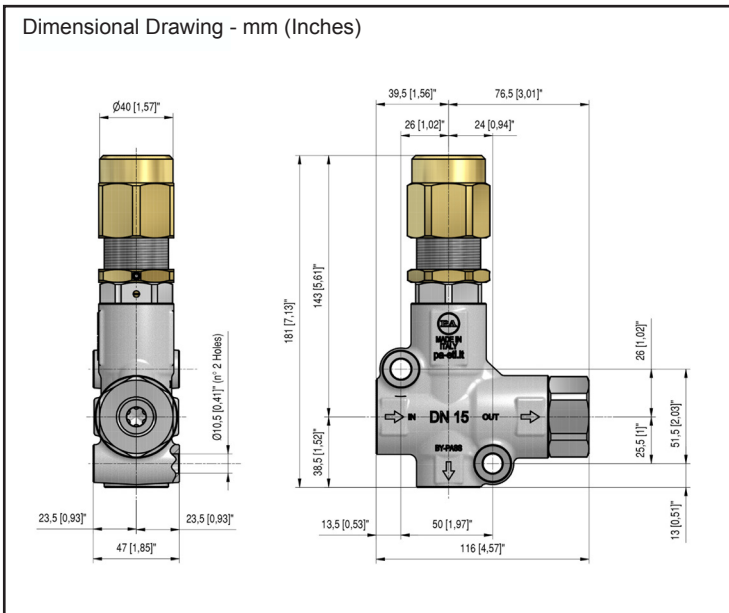

## Repair Kit #09824 Includes Item Numbers:

6, 7, 9, 10, 12, 13, 14, 17, 18,  
21, 22, 28, 29, 30, 31, 32

Operating Conditions	U.S.	Metric
Maximum Flow:	15.9 GPM	60 L/min
Maximum Pressure:	11,600 PSI	800 bar
Maximum Permitted:	12,800 PSI	880 bar
Minimum Pressure:	1160 PSI	80 bar
Maximum Temperature:	195 °F	90 °C
Inlet Port:	1/2" BSP	
Outlet Port:	1/2" BSP	
By-Pass:	1/2" BSP	
Weight:	5.5 lbs	2.5 kg

# GIANT

**Performance Under Pressure**

Giant Industries, Inc.  
900 N. Westwood Ave.  
Toledo, Ohio 43607  
PHONE 419-531-4600  
FAX 419-531-6836  
www.giantpumps.com

© Copyright 2018 Giant Industries, Inc.

# Instructions

## SELECTION

This product is to be utilized with clean fresh water or with small concentrations of normal detergents. For use involving more corrosive liquids, contact the Giant Industries technical department. Appropriate filtration should be installed when using unclean liquids. Choose the valve that best fits the operating parameters (system rated pressure, max flow and max temperature). In any case, the pressure of the machine should not exceed the permissible pressure rate shown on the valve.

## INSTALLATION

This accessory, on a system that produces hot water, must be fitted in **upstream from the heating element**. On a system that generates hot water, use accessories that limit the accidental increase of fluid temperature.

### Always install a safety valve that protects the pressurized inlet port.

Choose a correct nozzle size, which allows a regular discharge on bypass of at least 5% of the total flow of the system. This provides a constant pressure and avoids troublesome pressure spikes at closure. If the nozzle wears out, the pressure drops. On installation of a new nozzle, re-adjust the system to the original pressure setting.

## OPERATION

The valve regulates the maximum pressure of the system through a piston, which forces a ball to the correct position. This will then close the bypass opening. A check valve cuts out the delivery to the outlet of the unloader which will cause a "spike" in pressure that controls the movement of the piston. Each adjustment should be made when the system is running and the nozzle open.

**ATTENTION: The nut (pos 14) must never be removed otherwise a mechanical safety feature that limits the maximum pressure will be missing, which can cause serious damage to people and the machine.**

## DISCHARGE SYSTEM AND WATER ADDUCTION

The bypass line should be returned into a tank with baffles. When using a boost pump, with high pressure intake, it is necessary to install a pressure reducer in order to have an even flow supply and to protect the inlet water supply. When the system is opened and closed frequently, it is recommended to install a thermal protector valve in order to eliminate excessive temperatures in the system.

## REGULATIONS

**The accessory hereby described bears the CE marking in accordance with the Norms and Directives applied on the Declaration of Conformity.**

For a correct utilization, follow the directions described in this manual and reprint them on the Use and maintenance manual of the machine. Make sure that you are given **the Original Conformity Declaration** for the accessory chosen. The present manual is valid for all unloader valves named **22230**.

## MAINTENANCE

Maintenance has to be carried out by **Specialized Technicians**.

STANDARD: every 400 working hours (circa 10,000 cycles), check and lubricate the seals with water resistant grease.

SPECIAL: every 800 working hours (circa 20,000 cycles), control the wear of the seals and internal parts and if necessary, replace with original Giant parts taking care during installation and to lubricate with water resistant grease.

**ATTENTION: reassemble the valve in the correct manner paying special attention to the Nut (pos 16) by fastening with a drop of Loctite.**

**The manufacturer is not to be considered responsible for damage as a result from incorrect fitting and maintenance.**

Technical data, descriptions and illustrations are indicative and liable to modification without notice.

PROBLEMS	PROBABLE CAUSES	SOLUTIONS
Frequent unloader cycling	Damaged check valve o-ring Leaking connections Restricted bypass	Replace Check and renew Clean or adapt
Unloader does not reach pressure	Unloader not properly sized Piston o-rings worn out Material matter between seat and shutter Worn out nozzle	Change spring or type of valve Replace Clean the seat Replace
Pressure Peaks	There is not a min of 5% of total flow in bypass Excessive flow in bypass Spring totally compressed	Reset Change type of valve or adjust passages Loosen knob and change nozzle
Unloader does not bypass at low pressure	Jammed check valve Check valve o-ring worn out Material matter on check valve	Clean or replace Replace Clean