

Models MP4126HTC and MP4130HTC

Triplex Ceramic
Plunger Pump
Operating Instructions/
Repair and Service
Manual

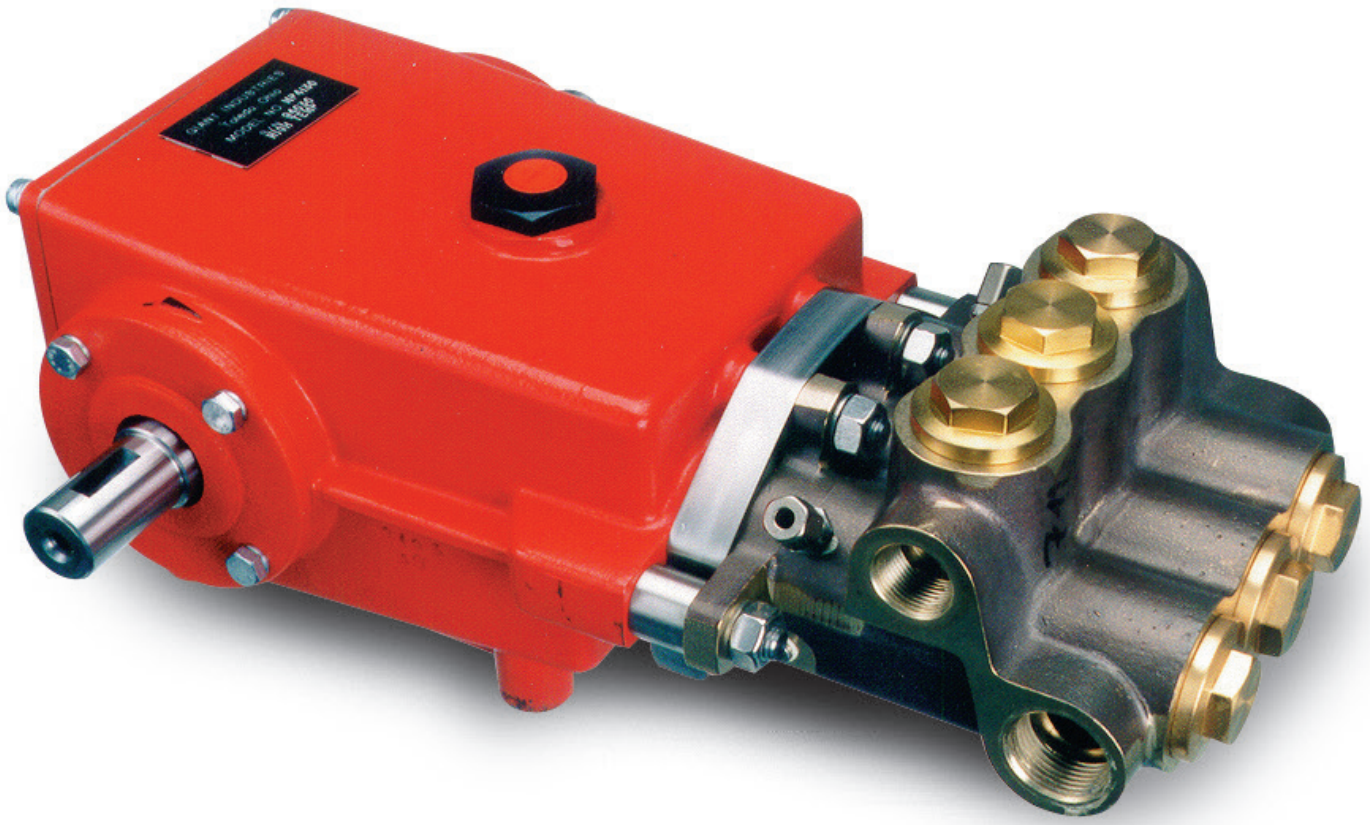

Shown with coolant connections



Updated 11/21

Contents:

Installation Instructions:	page 2
Pump Specifications:	page 3
Exploded View:	page 4
Parts List / Kits:	page 5
Repair Instructions:	page 6-10
Torque Specifications:	page 10
Troubleshooting/Recommended Spare Parts List	page 11
Dimensions:	back page
Warranty Information:	back page

INSTALLATION INSTRUCTIONS



Please read operating instructions carefully before putting the pump into operation!

Important! Do **not** use grease when renewing the high pressure plunger seal (pos. 40). Hot water causes grease to wash off the seal which in turn can jam valves! The new seals should only be oiled lightly before installation.

These operating instructions supplement the general operating instructions for the MP Series Pumps.

Supplementary Information

Giant Industries MP4126HT and MP4130HT have been especially constructed for pumping hot water e.g. steam boiler storage. The plunger seals (40) on the water side are made out of a high temperature-resistant material. To further increase seal life, rinsing chambers behind the high-pressure seals are filled at the factory with special hot water-resistant grease (Staburags NBU12). In combination with this, the pump has a grease nipple on one side and a hose connection on the other. As the pump will drip shortly after being put into operation, the leakage can be led off using a hose. The grease pad should be refilled twice a year (despite the presence of leakage). The pump high pressure seals should only be changed when leakage becomes a continual flow or when pressure drops or when a lack of water is established.

Alternatively, the manufacturer of the steam-boiler-unit installation engineer can replace the grease depository by using water cooling. To do this, the grease nipple is removed so a second hose connection can be fitted through which defined lower temperature water is led to cool the high pressure seals. Leakage from the high pressure seals is absorbed into the cooling water. Leakage to the outside only occurs if the low pressure seals, which seal the grease pad or cooling water, are worn.

Cooling Water Definition

The cold water 86 °F - 104 °F (30 °C - 40 °C) can be guided into the pump from either side and flows out on the opposite side e.g. into a drain or back to a condensate tank. The cold water flow rate should be at least 0.13 GPM (0.5 L/min) and must be put into use as soon as the pump is started.

If the cold water doesn't start flowing immediately when the pump is put into operation, the ceramic plunger (298) in particular, could crack under the cold shock.

Important! The cooling water must be delimited to avoid lime formation due to warming.

Plant Lay-Out

For correct functioning of the pump, the following points must be adhered to.

a) Pressure in Suction Side

The stipulated NPSHR is the minimum required pressure above the vapour pressure of the medium and is never to fall short of this figure. Temperature and vapour pressure of the medium, the geodetical height of the location, the flow rate and loss of friction in the suction line, must all be taken into consideration. It may be necessary to install a booster pump (centrifugal pump) in the suction line.

b) Pulsation

Due to its construction, the plunger pump creates pulsation in the suction and discharge lines. Suction pulsation in particular must be dampened in order to prevent resonance in the suction line which in turn, causes cavitation. Therefore, the pump is never to be connected by a rigid pipe but rather by a flexible hose (not reinforced by steel), and if possible, 1.5 to 2 times wider than the suction connection. If a booster pump is used, the hose is to be attached between the booster pump and the high pressure pump.

If several pumps are used, each pump must have its own suction line. If this can't be done, a suction air chamber or a suction flow stabilizer must be installed in front of each pump. The bladder in the stabilizer is to be pretensioned on location.

Depending on the lay-out of the plant, a pressure accumulator may be necessary on the discharge side. This pressure accumulator must be installed right behind the discharge outlet of the high pressure pump. We recommend the use of only one pressure accumulator in the discharge line in order to avoid irritation which could be caused by different pretension levels in the accumulators.

Gas-tension in both the suction flow stabilizer and in the pressure accumulator should be checked regularly.

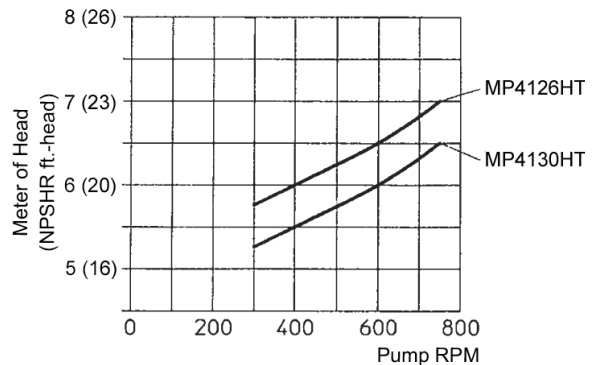

Specifications

Models MP4126HT & MP4130HT

	<u>U.S.</u>	<u>Metric</u>
Maximum Volume (MP4130HTC).....	10.5 GPM (630 GPH).....	39.7 L/min (2382 L/hr)
Maximum Volume (MP4126HTC).....	12.2 GPM (732 GPH).....	46.2 L/min (2722 L/hr)
Maximum Discharge Pressure.....	1160 PSI.....	80 Bar
Inlet Pressure	See NPSHR chart below	
Speed	Up to 750 RPM	
Plunger Diameter.....	1.18".....	30 mm
Plunger Stroke (MP4130HTC).....	1.0".....	26 mm
Plunger Stroke (MP4126HTC).....	1.18".....	30 mm
Crankcase Oil Capacity.....	33.8 fl.oz.	1 Liter
Temperature of Pumped Fluids	Up to 221° F	105° C
Inlet Ports	(2) 1" NPT	
Discharge Ports.....	(2) 3/4" NPT	
Pulley Mounting.....	Either side	
Shaft Rotation.....	Top of Pulley Towards Fluid End	
Weight	66 lbs.	33kg
Crankshaft Diameter.....	28mm	
NPSHR (MP4130HTC).....	21.3 ft.-head.....	6.5 mWs
NPSHR (MP4126HTC).....	22.9 ft.-head.....	7.0 mWs

Consult the factory for special requirements that must be met if the pump is to operate beyond one or more of the limits specified above.

PULLEY INFORMATION

Pulley selection and pump speed are based on a 1725 RPM motor and "B" section belts. When selecting desired GPM, allow for a ±5% tolerance on pumps output due to variations in pulleys, belts and motors among manufacturers.

1. Select GPM required, then select appropriate motor and pump pulley from the same line.
2. The desired pressure is achieved by selecting the correct nozzle size that corresponds with the pump GPM.

HORSEPOWER INFORMATION

Horsepower ratings shown are the power requirements for the pump. Gas engine power outputs must be approximately twice the pump power requirements shown above.

We recommend that a 1.1 service factor be specified when selecting an electric motor as the power source. To compute specific pump horsepower requirements, use the following formula:

$$HP = (GPM \times PSI) / 1450$$

MP4130HT(C) Horsepower Requirements							
RPM	GPM	290 PSI	580 PSI	725 PSI	870 PSI	1015 PSI	1160 PSI
400	5.6	1.1	2.3	2.8	3.4	3.9	4.5
500	7.0	1.4	2.8	3.5	4.2	4.9	5.6
600	8.4	1.7	3.4	4.2	5.1	5.9	6.8
700	9.8	2.0	3.9	4.9	5.9	6.9	7.9
750	10.5	2.1	4.2	5.3	6.3	7.4	8.5

MP4126HT(C) Horsepower Requirements							
RPM	GPM	290 PSI	580 PSI	725 PSI	870 PSI	1015 PSI	1160 PSI
400	6.5	1.3	2.6	3.3	3.9	4.6	5.2
500	8.1	1.6	3.2	4.1	4.9	5.7	6.5
600	9.8	2.0	3.9	4.9	5.9	6.9	7.8
700	11.4	2.3	4.6	5.7	6.8	8.0	9.1
750	12.2	2.4	4.9	6.1	7.3	8.5	9.8

Exploded View - MP4126HT and MP4130HT Pumps



MP4126HT and MP4130HT PUMPS PARTS LIST

<u>ITEM</u>	<u>PART #</u>	<u>DESCRIPTION</u>	<u>QTY.</u>	<u>ITEM</u>	<u>PART #</u>	<u>DESCRIPTION</u>	<u>QTY.</u>
1	06100	Crankcase	1	36	07267	Snap Ring	3
2	13000	Oil Filler Plug Assembly	1	39	07271	Pressure Ring	6
4	07243	Cover, Crankcase	1	40	06137	V-Sleeve	9
5	07244	O-Ring	1	41	07273	Support Ring	6
8	01008	Oil Dip Stick Assembly	1	42	07353	Tension Spring	3
9	01009	O-Ring, Dip Stick	1	42A	06103	Tension Plug, M42 x 1.5	3
10	01010	Screw, Crankcase Cover	4	42B	07354	O-Ring	3
11	01011-0400	Spring Ring	4	43	04743	Valve Casing	1
12	07109	Oil Drain Plug, 1/2" BSP	1	44	07280	Valve Seat	6
13	06015	O-Ring	1	44A	07281	O-Ring	6
14	07245	Bearing Cover	2	45	06791-0100	Valve Plate	6
15	07247	Seal, Crankshaft	2	46	07283	Valve Spring	6
16	07627	O-Ring	2	47	07284	Spring Retainer, Discharge	3
17	07114	Hex Screw, Bearing Cover	9	48	07356	Plug, Brass, M36 x 1.5	3
20	07248	Roller Bearing, Tapered	2	48A	07332	O-Ring	3
20A	07249	Fitting Disc	2	49	06139	Stud Bolt	6
20B	06962	Fitting Disc	2	49A	06140	Fitting Sleeve w/Extension	2
21	05375	Shaft Protector	1	49B	06141	Extension	4
22	04149	Crankshaft, MP4126HT(C)	1	49C	07319	Centering Sleeve	2
22	07251	Crankshaft, MP4130HT(C)	1	50	07158	Hexagon Nut	6
23	13331	Key	1	50A	07159	Disc	6
24	07253	Connecting Rod Assembly	3	51	06110	Spacer Pipe	3
25	07596	Crosshead Assembly	3	52	06112	Inlet Valve Housing	3
28	07255	Crosshead Pin	3	53	07332	O-Ring	3
29A	07256	Centering Sleeve	3	54	06115	Spring Retainer	3
29B	07261	Plunger Pipe	3	55	06626	Plug, 1" NPT	1
29C	04150	Tension Screw	3	56	04732	Plug, 3/4" NPT	1
29D	07258	Copper Ring	3	57	13020	Disc for Crankshaft	1
29E	04151	Plunger Extension	3	59	03298	Lubrication nipple, 1/8" BSP	1
30	06136	Oil Scraper	3	60	03299	Hose Barb Fitting, 1/8" BSP	1
31	07260	Crankcase Oil Seal	3	62	06142	Tin Lid	1

MP4126HT and MP4130HT SERIES REPAIR KITS

Plunger Packing Kit

Part # 09532

<u>Item #</u>	<u>Part #</u>	<u>Description</u>	<u>Qty.</u>
40	06137	V-Sleeve	9
42B	07354	O-Ring	3
53	07332	O-Ring	3

Valve Assembly Kit

Part # 09533

<u>Item #</u>	<u>Part #</u>	<u>Description</u>	<u>Qty.</u>
42B	07354	O-Ring	3
44	07280	Valve Seat	6
44A	07281	O-Ring	6
45	06791-0100	Valve Plate	6
46	07283	Valve Spring	6
47	07284	Spring Retainer, Discharge	3
48A	07332	O-Ring	3
53	07332	O-Ring	3
54	06115	Spring Retainer	3

REPAIR INSTRUCTION - MP4126HT and MP4130HT

Disassembly sequence of the GIANT MP4126HT and MP4130HT Pumps

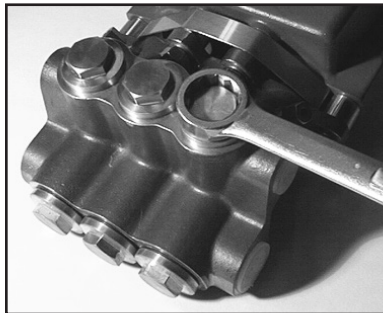

1. With a 27mm wrench, remove the three discharge plugs (#48) and three inlet plugs (#42A) from the manifold (#43).



2. Inspect the plug o-rings (#48A and #42B) and replace as necessary.

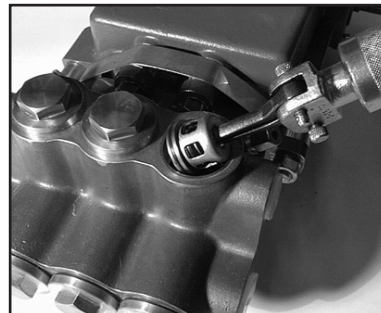

3. Using a valve puller (available from Snap-On-Tools), remove the discharge valve assembly (#44 - #47).

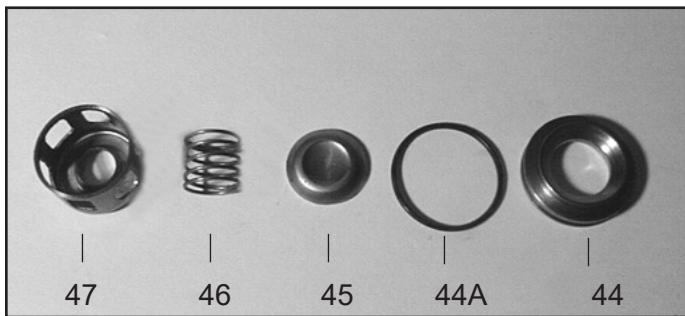

4. Inspect all parts, especially the seating surface of the valve plate (#45) and valve seat (#44) and replace as necessary.

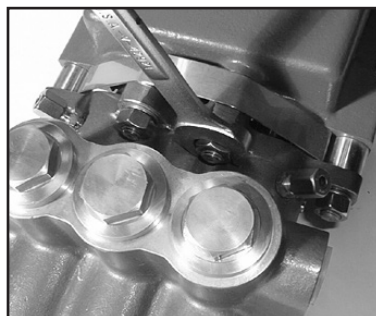

5. Remove the six manifold stud nuts (#50) with a 19mm wrench. Remove the spring washers (#50A). Tap the back of the manifold with a rubber mallet to dislodge and slide it off the studs (#49).

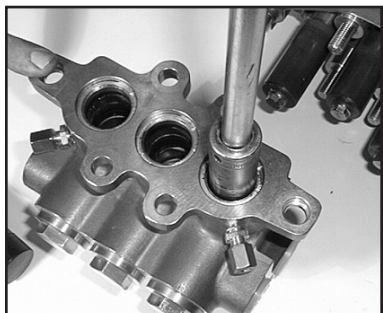

6. To remove the inlet valve assembly, insert a 13mm socket with extension through the rear of the inlet manifold (#43) port and tap it firmly with a hammer. This will force the tension spring (#42), valve housing (#52) and the remainder of the inlet valve assembly (#44-46/51) out through the front of the inlet port.

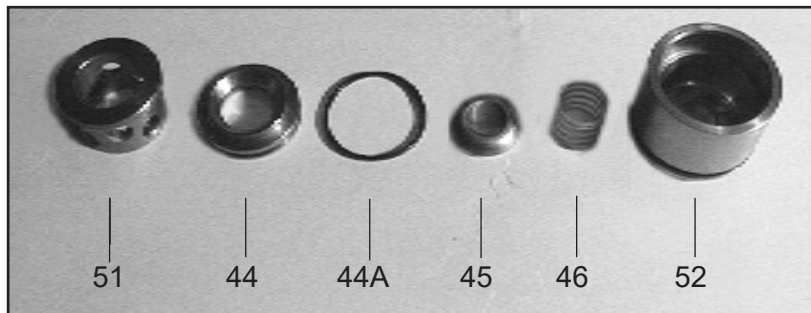

7. Pull the inlet valve assembly apart for inspection. Any resistance may be overcome by placing the valve housing (#52) in a brass jawed vise and carefully tapping the back of the valve plate (#45) with a screwdriver. Remove the spacer pipe (#51) valve seats (#44), o-ring (#44A), valve plate (#45), spring (#46) and replace them as necessary.

REPAIR INSTRUCTION - MP4126HT and MP4130HT

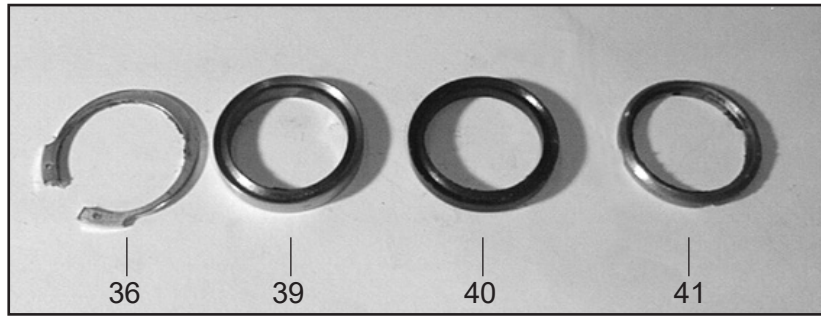
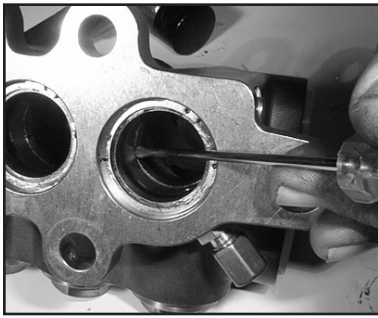

8. From the back of the manifold (#43), remove the packing assembly (#'s 42, 41, 40, and 39) by tapping assembly out from the back to the front.
9. Turn the manifold (#43) over and remove the rear v-sleeve snap ring (#36). Remove rear pressure ring (#39), rear v-sleeve (#40) and rear support ring (#41). These parts should slide out with little resistance. If necessary, a screwdriver may be used to pry outward. Replace all rubber parts and inspect the metal parts for wear.

10. **Note: The following procedure is only necessary if a stud bolt (#49) has been damaged and must be replaced.** To remove the manifold studs (#49), place a stud nut (#50), lock washer (#50A), and second nut on each stud. Tighten the nuts against each other. Hold the front nut with one wrench, and remove the stud bolt by turning the rear nut counterclockwise with another wrench. To reassemble, turn the front stud bolt nut clockwise.

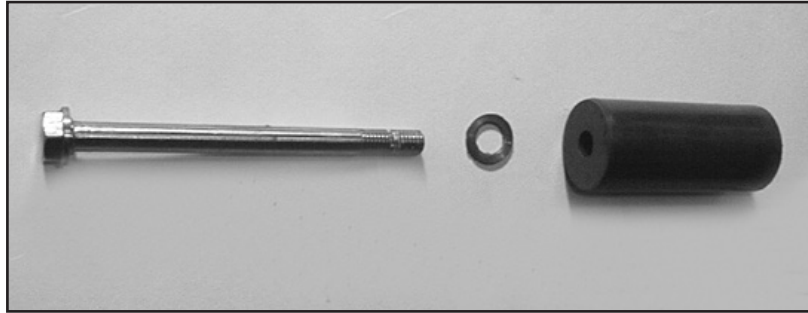

11. To remove the ceramic plungers, turn the plunger bolt (#29C) counterclockwise with a 13mm socket. Use a steady torque to prevent ceramic plunger sleeve damage. Loosen and remove the plunger bolt assembly (#29C and #29D) and replace the seal washer (#29D).

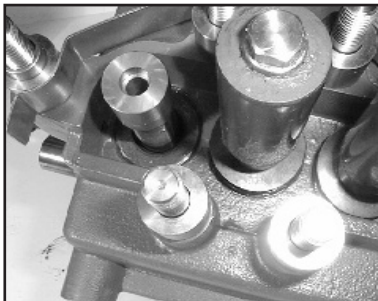

- 11a. Inspect the crankcase oil seals (#31) for evidence of leaking. If there is oil on the crankcase (#1) at the sight of the oil seals, they must be replaced. The oil seals are replaced after removing the crosshead/plunger assembly (#25) as described below.

Contact Giant Industries for service school information. Phone: (419) 531-4600

REPAIR INSTRUCTION - MP4126HT and MP4130HT

Gear End Disassembly

Note: Make certain that the plungers (29B) have been removed before starting the following sequence.

12. Make sure the oil is drained from the pump before removing the crankcase cover (#4). Remove all screws (#10). Inspect the crankcase cover o-ring (#5) for damage and replace it as necessary.
13. Remove the connecting rod screws and washers (#s 24A) with a 6mm allen wrench. Remove the back halves of each connecting rod (#24). Push the connecting rods down as far as possible into the crankcase (#1) housing. **Note that the connecting rod halves are numbered (or colored) and that the numbers (or colors) must be matched for reassembly.**
14. Remove the crankshaft bearing cover screws (#17) with a 13mm wrench. Remove the key (#23) from the crankshaft (#22).
15. Remove the bearing cover (#14) and any shims (#20A) if any. **Remember to replace shims on the same side of the crankcase (#1) during the reassembly.**
16. Steady the pump gear end and, using a rubber mallet, tap the crankshaft (#22) from one side. The far side bearing race will be removed and the near side race will remain in the crankcase. The roller bearings (#20) will remain on the crankshaft with the Giant bearing tool (Tool-1). When both ends are free, the crankshaft can be removed by hand.
17. To remove the remaining bearing race, place a dowel against the inside edge of the race and tap it out with a rubber mallet. This is done only if the race wear surface has been damaged.
18. Inspect the bearing race removed with the crankshaft (#22) and replace if wear surface is damaged.
19. **Note: The following procedure is only necessary if the inspection shows evidence of heavy wear.** Inspect the crankshaft (#22) and bearings (#20) for wear. To remove the roller bearings from the crankshaft, use a three inch push puller with a pulley attachment. To remount the bearings use the Giant Bearing Tool (Tool-1) and tap the bearings down the well-lubricated crankshaft. Be sure that the bearing is firmly seated.
20. Remove the connecting rod (#24) with the attached crosshead/plunger assembly (#25) from the crankcase (#1) by pulling it straight out. The oil seals (#31) may now be removed by tapping them out through the front of the crankcase. Be careful not to damage the snap ring.
21. Inspect the surfaces of the crosshead/plunger assembly (#25) and connecting rods (#24) for heavy scoring or galling due to poor lubrication. Check for play at the joint between connecting rod crosshead/plunger assembly.
22. To remove the crosshead pin (#28) from the crosshead/plunger assembly (#25), the assembly should be positioned in such a manner to prevent damage to the crosshead when driving the pin out. The crosshead pin can be driven out by tapping on the tapered side of the pin

Reassembly sequence

Note: Always take time to lubricate all metal and nonmetal parts with a light film of oil before reassembly. This step will help ensure a proper fit, at the same time it will protect the pump nonmetal parts (elastomers) from cutting and scoring.

23. Take the crosshead/plunger rod assembly and insert the connecting rod (#24) into the crosshead/plunger assembly (#25). Drive the tapered end of the crosshead pin (#28) into the beveled side of the crosshead and through the connecting rod completing the assembly.

Note: The crosshead pin should not extend beyond either side of the crosshead in order to prevent damage to the crosshead bore of the crankcase.

24. Inspect the crankcase crosshead guides for any possible damage.
25. Replace the connecting rod (#24), crosshead/plunger rod assembly (#25) into the crankcase (#1).
26. If removed previously, replace the far side bearing race into the crankcase. Tap with a rubber mallet until the edges are flush with the crankcase surface.
27. Remove the old crankshaft seal (#15) from the bearing cover (#14). Lubricate the edges of the new seal and install with the Giant bearing tool (Tool-1). Remove the bearing tool and tap around the perimeter of the seal with a rubber mallet to firmly seat the seal. Position the far bearing cover on the crankcase (#1) and insert the cover bolts (#17). Tighten the cover evenly to the crankcase, setting the bearing into position. Torque the cover bolts to 221 inch-pounds (25 Nm).
28. Insert the crankshaft (#22) with the mounted bearings (#20) through the near side of the crankcase (#1). **Make certain that the numbers (or colors) or the crankshaft correspond to the numbers (or colors) on the connecting rods (#24).** Reinstall the near side bearing race by inserting it into the crankcase. Supporting the crankshaft with one hand, tap the race with a rubber mallet until the edge is flush with the crankcase.

REPAIR INSTRUCTION - MP4126HT and MP4130HT

29. Replace any shims (#20A) and position the bearing cover (#14) as before. Tighten the bearing cover bolts (#17) evenly to position the bearing race. Torque the bolts to 221 inch-pounds (25 Nm). Once the crankshaft reassembly is complete, oil the crankshaft races freely before replacing the connecting rod (#24) end caps.
30. Reassemble the connecting rods (#24), matching the numbered (or colored) halves. Torque the connecting rod bolts (#24A) to 106 inch-pounds (12 Nm).
31. To replace the oil seal (#31) apply locktite to the outside edges of the seal and install from the front of the crankcase (#1). The side of the seal with the spring must face the oil. Make sure that the face of the seal is flush with the crankcase.

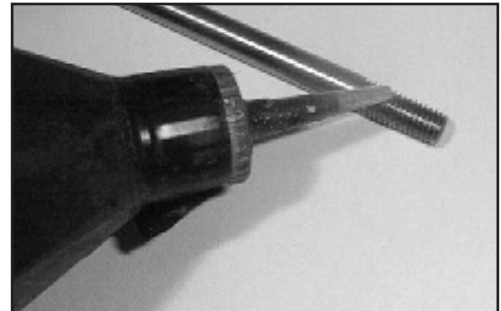
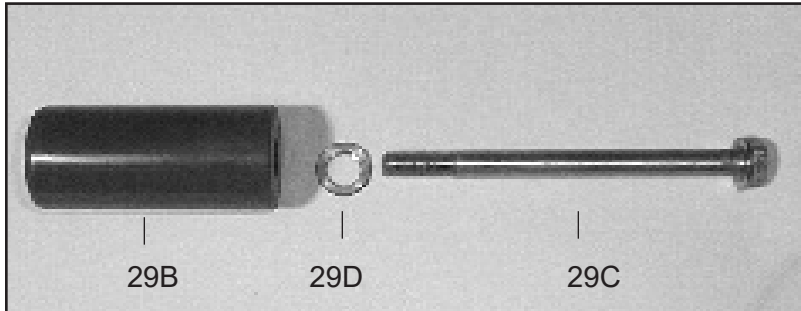

32. Inspect the ceramic plungers (#29B) and replace them if necessary. Clean the ends of the ceramic and remount onto the crosshead/plunger assembly. Make certain that the end of the plunger which is not counter-bored is facing the discharge side of the pump. Install the seal washer (#29D) on the bolt assembly.

33. Clean the bolt threads (#29C), apply locktite, and remount.

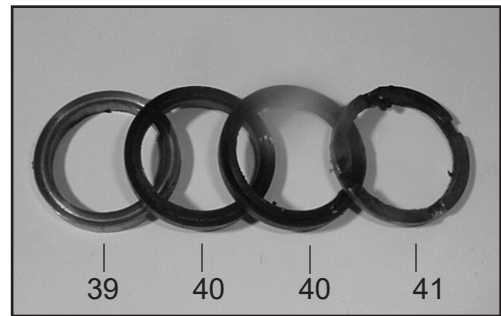
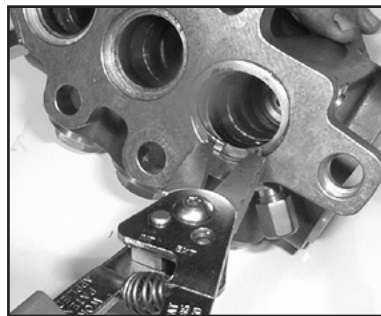
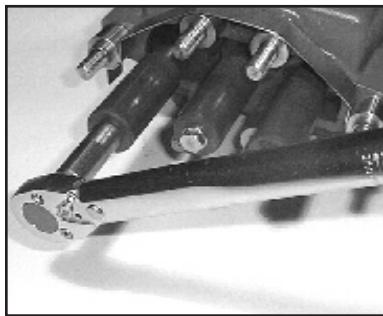

- 33A. Torque the ceramic plunger bolt assembly to 22 foot-pounds (30 Nm). If originally removed, reinstall the stud bolts (#49).

34. Install the rear support ring (#41), rear v-sleeve (#40), rear pressure ring (#39). Install the snap ring (#36).

35. Reinstall the pressure ring (#39), v-sleeves (#40) and support ring (#41) into each plunger bore. Reinstall the tension spring (#42).



36. Reassemble the discharge valve assembly by placing the valve plate (#45), spring (#46), and spring retainer (#47) on top of the valve seat (#44). Press fit together.

REPAIR INSTRUCTION - MP4126HT and MP4130HT

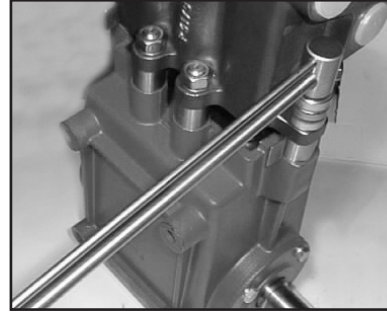

37. Place the entire discharge assembly into discharge port making certain the assembly is properly seated. Install discharge plug (#48) and hand tighten.

38. Reassemble the inlet valve assembly in the reverse order of step #7. Make certain all the components are press fit together and that the spring retainer (#54) is slightly counter sunk in the valve housing (#52). Grease the o-ring (#53) and install it on to the valve housing. Reinstall the entire inlet valve assembly into the manifold (#43). install the tension plugs (#42A) and tighten.

39. Lubricate the plungers (29B) again and slide the manifold (#43) gently and evenly over the plungers. Press the manifold firmly into place against the crankcase (#1). Install the spring washer (#50A) and tighten the manifold stud nuts (#50) to 59 foot-pounds (80 Nm)

MP4126HT and MP4130HT TORQUE SPECIFICATIONS

Position	Item#	Description	Torque Amount
10	01010	Screw, Crankcase	221 in.-lbs. (25 Nm)
12	07109	Plug	29.5 ft.-lbs (40 Nm)
17	07114	Hex Screw, Bearing Cover	221 in.-lbs (25 Nm)
24A	07122	Hex Screw, Connecting Rod	106 in.-lbs (12 Nm)
29C	04150	Bolt, Plunger	22 ft.-lbs (30 Nm)
42A	06103	Plug, Inlet	107 ft.-lbs. (145 Nm)
48	07356	Plug, Discharge	107 ft.-lbs. (145 Nm)
50	07158	Nut, Manifold Stud	59 ft.-lbs (80 Nm)

PUMP SYSTEM MALFUNCTION

<u>MALFUNCTION</u>	<u>CAUSE</u>	<u>REMEDY</u>
The Pressure and/or the Delivery Drops	Worn packing seals Broken valve spring Belt slippage Worn or Damaged nozzle Fouled discharge valve Fouled inlet strainer Worn or Damaged hose Worn or Plugged relief valve on pump Cavitation Unloader	Replace packing seals Replace spring Tighten or Replace belt Replace nozzle Clean valve assembly Clean strainer Repair/Replace hose Clean, Reset, and Replace worn parts Check suction lines on inlet of pump for restrictions Check for proper operation
Water in crankcase	High humidity Worn seals	Reduce oil change interval Replace seals
Noisy Operation	Worn bearings Cavitation	Replace bearings, Refill crankcase oil with recommended lubricant Check inlet lines for restrictions and/or proper sizing
Rough/Pulsating Operation with Pressure Drop	Worn packing Inlet restriction Accumulator pressure Unloader Cavitation	Replace packing Check system for stoppage, air leaks, correctly sized inlet plumbing to pump Recharge/Replace accumulator Check for proper operation Check inlet lines for restrictions and/or proper size
Pressure Drop at Gun	Restricted discharge plumbing	Re-size discharge plumbing to flow rate of pump
Excessive Leakage	Worn plungers Worn packing/seals Excessive vacuum Cracked plungers Inlet pressure too high	Replace plungers Adjust or Replace packing seals Reduce suction vacuum Replace plungers Reduce inlet pressure
High Crankcase Temperature	Wrong Grade of oil Improper amount of oil in crankcase	Giant oil is recommended Adjust oil level to proper amount

Preventative Maintenance Check-List & Recommended Spare Parts List						
Check	Daily	Weekly	50hrs	Every 500 hrs	Every 1500 hrs	Every 3000 hrs
Oil Level/Quality	X					
Oil Leaks	X					
Water Leaks	X					
Belts, Pulley		X				
Plumbing		X				
Recommended Spare Parts						
Oil Change (1 Quart)			X	X		
Seal Kit (1 kit/pump) (See page 5 for kit list)					X	
Valve Spare Parts (1 kit/pump) (See page 5 for kit list)						X

MP4126HT and MP4130HT DIMENSIONS - inches (mm)

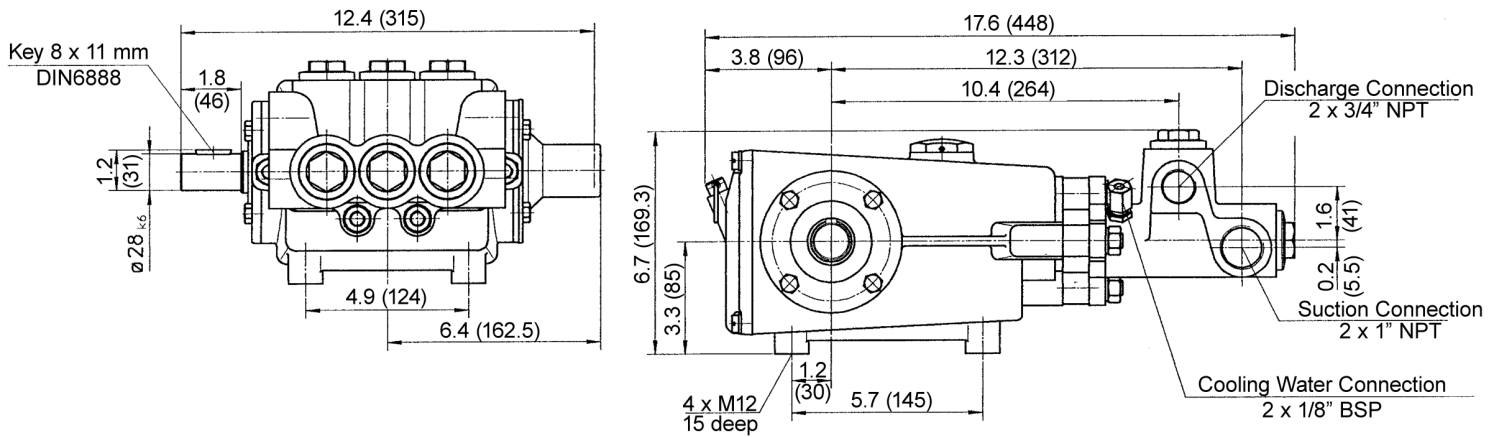

GIANT INDUSTRIES LIMITED WARRANTY

Giant Industries, Inc. pumps and accessories are warranted by the manufacturer to be free from defects in workmanship and material as follows:

1. Five (5) years from the date of shipment for all pumps used in portable pressure washers with NON-SALINE, clean water applications.
2. Two (2) years from the date of shipment for Giant pumps used in car wash applications.
3. One (1) year from the date of shipment for all other Giant industrial and consumer pumps.
4. Six (6) months from the date of shipment for all rebuilt pumps
5. Ninety (90) days from the date of shipment for all Giant accessories.

This warranty is limited to repair or replacement of pumps and accessories of which the manufacturer's evaluation shows were defective at the time of shipment by the manufacturer. The following items are NOT covered or will void the warranty:

1. Defects caused by negligence or fault of the buyer or third party.
2. Normal wear and tear to standard wear parts.
3. Use of repair parts other than those manufactured or authorized by Giant.
4. Improper use of the product as a component part.
5. Changes or modifications made by the customer or third party.
6. The operation of pumps and or accessories exceeding the specifications set forth in the Operations Manuals provided by Giant Industries, Inc.

Liability under this warranty is on all non-wear parts and limited to the replacement or repair of those products returned freight prepaid to Giant Industries which are deemed to be defective due to workmanship or failure of material. A Returned Goods Authorization (R.G.A.) number and completed warranty evaluation form is required prior to the return to Giant Industries of all products under warranty consideration. Call (419)-531-4600 or fax (419)-531-6836 to obtain an R.G.A. number.

Repair or replacement of defective products as provided is the sole and exclusive remedy provided hereunder and the MANUFACTURER SHALL NOT BE LIABLE FOR FURTHER LOSS, DAMAGES, OR EXPENSES, INCLUDING INCIDENTAL AND CONSEQUENTIAL DAMAGES DIRECTLY OR INDIRECTLY ARISING FROM THE SALE OR USE OF THIS PRODUCT.

THE LIMITED WARRANTY SET FORTH HEREIN IS IN LIEU OF ALL OTHER WARRANTIES OR REPRESENTATION, EXPRESS OR IMPLIED, INCLUDING WITHOUT LIMITATION ANY WARRANTIES OR MERCHANTABILITY OR FITNESS FOR A PARTICULAR PURPOSE AND ALL SUCH WARRANTIES ARE HEREBY DISCLAIMED AND EXCLUDED BY THE MANUFACTURER.



WARNING: This product might contain a chemical known to the State of California to cause cancer, and birth defects or other reproductive harm.

For more information go to www.P65Warnings.ca.gov

GIANT
Performance Under Pressure

GIANT INDUSTRIES, INC., 900 N. Westwood Ave., Toledo, Ohio 43607
PHONE (419) 531-4600, FAX (419) 531-6836, www.giantpumps.com
© Copyright 2021 Giant Industries, Inc.

11/21 MP4126_30HTC.indd