

Models

CP217-5123
CP218-5123
CP220-5123
CP230-5123

Triplex Ceramic
Plunger Pump
Operating Instructions/
Repair and Service Manual

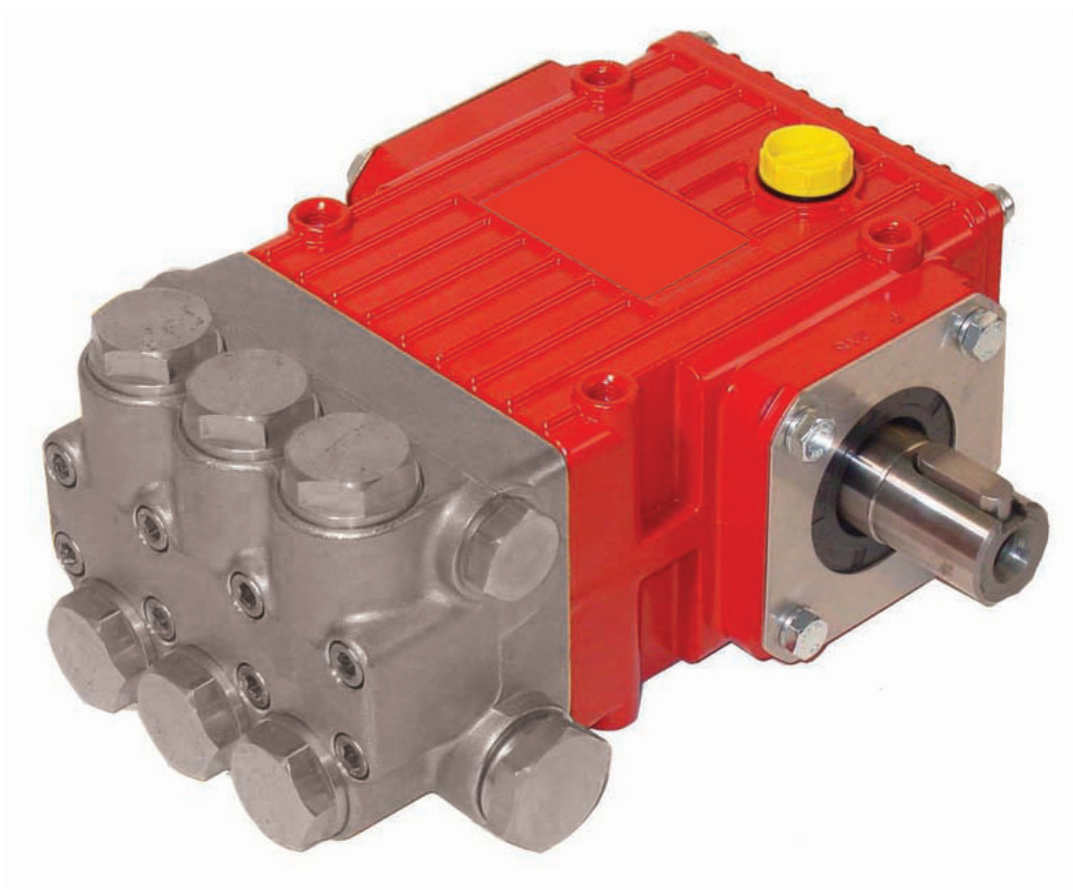

Contents:

Installation Instructions:	page 2
Pump Specifications:	page 3
Exploded View:	page 4
Parts List:	page 4
Repair Kits:	page 5
Torque Specifications:	page 5
Trouble Shooting:	page 5
Repair Instructions:	pages 6-7
Pump Mounting Selection Guide:	page 7
Preventative Maintenance:	page 7
Dimensions:	back page
Warranty Information:	back page

INSTALLATION INSTRUCTIONS

Several important points are to be observed when setting up, installing and operating the pumps: Pump revolutions (rpm) should be kept as low as possible; the higher the revolutions the greater the danger of cavitation (gas formation).

An input pressure of at least 13.1 ft.-head (4 metres of liquid column) above the pump should be present. In addition, the inlet connection should be as short as possible, without any pressure reducing fittings (e.g. filter, kick-back valves, elbows, etc) and its cross section at least 2x larger than the diameter of the pump suction port.

To avoid heat influx, the intake line should be covered with good insulation material.

The intake line as well as the outlet line should be elastic to decouple the system from mechanical and hydraulic pump vibrations.

The pump should be run cold before the process operation. To do this, a T-piece should be fitted on the pump outlet port to enable the CO₂ to circulate back to the tank during a cold running phase of 30

sec. to 3 min. (depending on the conditions) until the pump head has the same medium temperature as the tank.

The discharge line diameter should be as narrow as possible to avoid parts of gas flowing back into the pump. The pipe diameter at the T-piece should be narrowed to slow the speed of the cooling circulation back to the tank to approximately 66-98 ft./sec (20-30 m/sec).

If the pump (or drive) is completely covered with ice after a long stoppage, it is not to be put into operation until the drive has thawed. Starting the pump where ice or frozen oil are present will cause major damage to the drive. Motor oil of SAE 0W 40 quality is to be used for the pump drive as this oil has better lubricating properties at low temperatures. The unloader valves in the Speck product range do not offer suitable protection for the pumps. Safety valves with special seals must be used.

The attached data sheet gives further information on available pump models for CO₂.

Finally, remember that high pressure operation in a pump system has many advantages. But, if it is used carelessly and without regard to its potential hazard, it can cause serious injury.

IMPORTANT OPERATING CONDITIONS

Failure to comply with any of these conditions invalidates the warranty.

1. Prior to initial operation, add oil to the crankcase so that oil level is between the two lines on the oil dipstick. **DO NOT OVERFILL.**

When pumping CO₂ at temperatures under 18 °F (0 °C) use Oil SAE 0W-40.

For Food Grade applications, use Giant oil (01157).

Crankcase oil should be changed after the first 50 hours of operation, then at regular intervals of 500 hours or less depending on operating conditions.

2. Pump operation must not exceed rated pressure, volume, or RPM. A pressure relief device must be installed in the discharge of the system.

3. Acids, alkalines, or abrasive fluids cannot be pumped unless approval in writing is obtained before operation from Eco₂ Blast.

Specifications

Models CP218/CP220/CP230-5123

	U.S.	(Metric)
Volume (CP217-5123)	0.73 GPM	(2.7 L/min)
Volume (CP218-5123)	1.4 GPM	(5.3 L/min)
Volume (CP220-5123)	1.9 GPM	(7.3 L/min)
Volume (CP230-5123)	0.45 GPM	(1.7 L/min)
Discharge Pressure	2000 PSI	(140 bar)
Inlet Pressure.....	580 PSI	(40 bar)
RPM.....		Up to 750 RPM
Plunger Diameter.....	0.71"	18 mm
Stroke (CP217-5123).....	0.22"	5.5 mm
Stroke (CP218-5123).....	0.39"	10.0 mm
Stroke (CP220-5123).....	0.56"	14.1 mm
Stroke (CP230-5123).....	0.13"	3.4 mm
Temperature of Pumped Fluids.....	Up to 32 ° F	(0 ° C)
Inlet Ports		(2) 1/2" BSP
Discharge Ports		(2) 3/8" BSP
Shaft Rotation		Top of Pulley Towards Fluid End
Crankshaft Diameter.....	0.94"	24mm
Shaft Mounting.....		Either Side
Weight.....	13 lbs. 4oz.	(6.0 kg)
Crankcase Oil Capacity	8.1 fl.oz.	(0.24 liters)

Materials

Manifold	316 Stainless Steel
Plungers.....	Solid Ceramic Oxide
Valves	High Grade Stainless Steel
Seals.....	Teflon and Nitrile with EPDM O-Rings
Gear End	Anodized Aluminum

Consult the factory for special requirements that must be met if the pump is to operate beyond one or more of the limits specified above.

Horsepower Ratings:

We recommend a 1.15 service factor be specified when selecting an electric motor as the power source.

To compute electric motor horsepower required, use the following formula: $HP = (GPM \times PSI) / 1450$.

The formula to determine the horsepower required for a gas engine is: $HP = (GPM \times PSI) / 1150$.

The formula to determine the horsepower required for a diesel engine is: $HP = (GPM \times PSI) / 1250$.

For the Application of a Hydraulic Motor:

To Determine the Torque of a Hydraulic Motor -- $(GPM \times PSI \times 36.77) / RPM = \text{Torque (in-lbs)}$

Calculating RPM / GPM of Pump:

A pump must be connected to an electric motor or gas or diesel engine with the correct ratio of pulleys and belts to attain the required speed and GPM. The use of a Variable Frequency Drive (VFD) may also be used to control the RPM of a properly sized electric motor when variable flows are required.

(Max. Pump RPM / Rated Pump GPM) x Required Pump GPM = **Required Pump RPM**

To calculate a pulley diameter one (1) pulley diameter and the required pump RPM must be known:

$(\text{Pump RPM} \times \text{Pump Pulley Diameter}) / \text{Motor RPM} = \text{Motor Pulley Diameter}$

$(\text{Motor RPM} \times \text{Motor Pulley Diameter}) / \text{Pump RPM} = \text{Pump Pulley Diameter}$

Exploded View - CP218/CP220/CP230-5123 Pumps

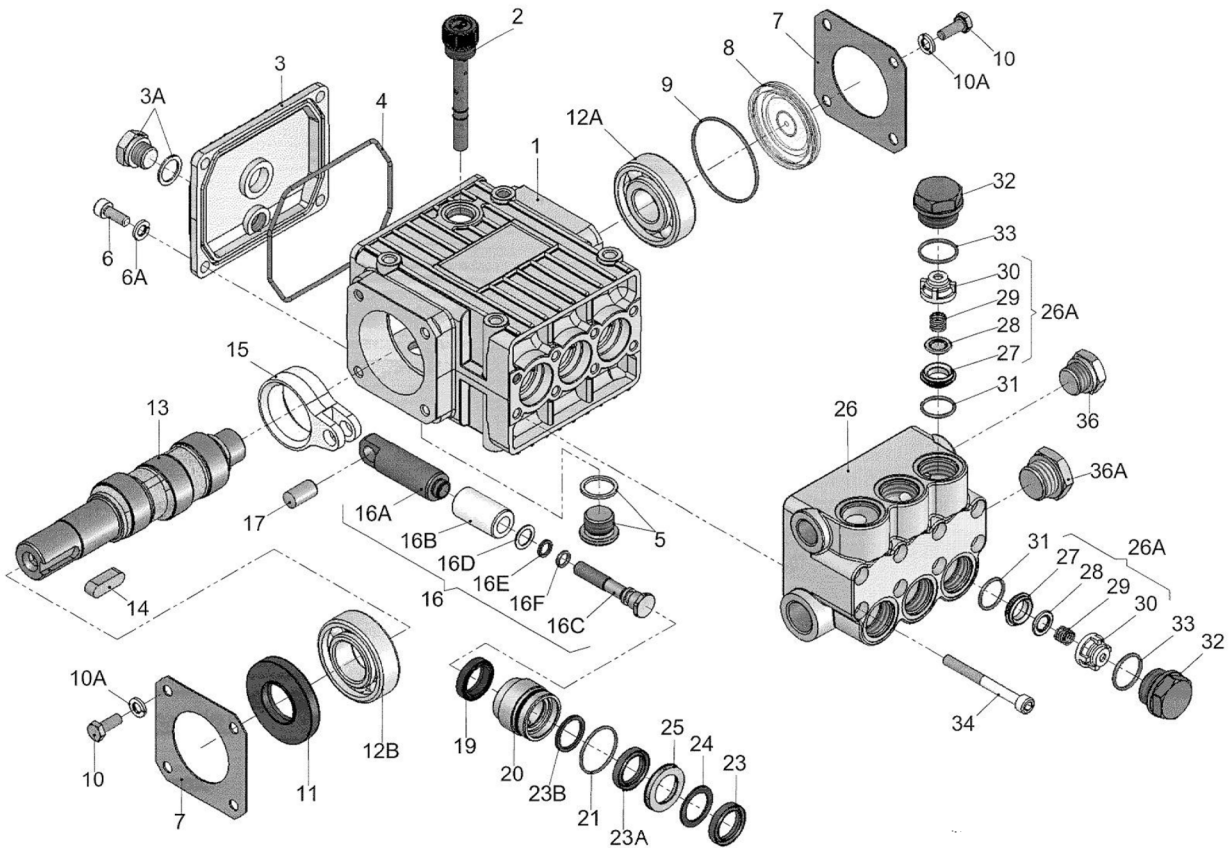

CP218/CP220/CP230-5123 Pump Spare Parts

<u>Item</u>	<u>Part No.</u>	<u>Description</u>	<u>Qty.</u>	<u>Item</u>	<u>Part No.</u>	<u>Description</u>	<u>Qty.</u>
1	CP08300C	Crankcase	1	16D	CP07204-0100	Copper Gasket	3
2	CP08301	Oil Dipstick with O-Ring	1	16E	CP07203	Support Ring	3
3	CP08302	Crankcase Cover, Short	1	16F	CP07023	O-Ring	3
3A	CP07190-0100	Drain Plug & Gasket	1	17	CP08442	Wrist Pin	3
4	CP08005	O-Ring	1	19	CP08356	Oil Seal	3
5	CP08185-0100	Oil Drain Plug w/seal	1	20	CP08444A-0100	Seal Case	3
6	CP07188-0100	Screw, Crankcase Cover	4	21	CP06815	O-Ring	3
6A	CP07223-0100	Spring Washer	4	23	CP08087	V-Sleeve, Weep	3
7	CP08303	Bearing Cover	2	23A	CP08087-0020	V-Sleeve, Teflon	3
8	CP08491	Oil Sight Glass	1	23B	CP06163	Drip Shield	3
9	CP07193	O-Ring	1	24	CP07904	Pressure Ring	3
10	CP07225-0100	Screw with Lock Washer	8	25	CP08445-0100	Weep Return Ring	3
10A	CP07223-0100	Spring Washer	8	26	CP06582-5000	Valve Casing	1
11	CP08331	Radial Shaft Seal	1	26A	CP04273	Valve Assembly (Includes 27-31)	6
12A	CP04917	Ball Bearing	1	27	CP07849-0100	Valve Seat	6
12B	CP01086	Ball Bearing	1	28	CP06809	Valve Plate	6
13	CP03026	Crankshaft (CP217)	1	29	CP06816	Valve Spring	6
13	CP04920	Crankshaft (CP218)	1	30	CP07907	Valve Spring Retainer	6
13	CP04919	Crankshaft (CP220)	1	31	CP06817	O-Ring	6
13	CP04918	Crankshaft (CP230)	1	32	CP07928-0100	Valve Plug	6
14	CP06207	Fitting Key	1	33	CP06818	O-Ring	6
15	CP08333	Connecting Rod	3	34	CP08316-0100	Hex Head Cap Screw	8
16	CP08469-0100	Plunger, Complete	3	36	CP12138	Plug, 3/8" BSP	1
16A	CP08468-0100	Plunger Base	3	36A	CP07109-0400	Plug, 1/2" BSP	1
16B	CP08455	Plunger Pipe	3				
16C	CP08456-0100	Tension Screw	3				

CP218/CP220/CP230-5123 Pump Repair Kits

Valve Assembly Kit

Part # CP09556-0123

<u>Item #</u>	<u>Part #</u>	<u>Description</u>	<u>Qty.</u>
26A	CP04273	Valve Assembly, Complete	6
31	CP06817	O-Ring	6
33	CP06818	O-Ring	6

Oil Seal Kit

Part # 09144

<u>Item #</u>	<u>Part #</u>	<u>Description</u>	<u>Qty.</u>
19	CP08356	Oil Seal	3

Plunger Packing Kit

Part # CP09554-5123

<u>Item #</u>	<u>Part #</u>	<u>Description</u>	<u>Qty.</u>
21	CP06815	O-Ring	3
23	CP08087	V-Sleeve, weep	3
23A	CP08087-0020	V-Sleeve, brown	3
23B	CP06163	Drip Shield	3
24	CP07904	Pressure Ring	3

Pump Torque Specifications

<u>Item</u>	<u>Part No.</u>	<u>Description</u>	<u>Lubrication</u>	<u>Torque Amount</u>
3A	07190	Drain Plug		22 ft.-lbs. (30 Nm)
5	06273	Oil Drain Plug w/Gasket		22 ft.-lbs. (30 Nm)
6	07188	Screw, Short Cover		88 in.-lbs. (10 Nm)
10	07225	Screw w/Lock Washer		88 in.-lbs. (10 Nm)
16C	08456	Tension Screw	Loctite 243	200 in.-lbs. (22.5 Nm)
16D	07676	Copper Gasket	Loctite 243	N/A
32	07928	Valve Plug	Loctite 243	55 ft.-lbs. (75 Nm)
34	08316	Hex Head Cap Screw		106 in.-lbs. (12 Nm)

CAUTION: EPDM o-rings must not come into contact with mineral oil or mineral grease. Use silicone grease only.

Preventative Maintenance Check List & Recommended Spare Parts List

Check	Daily	Weekly	50 Hrs.	Every 500 Hrs	Every 1500 Hrs	Every 3000 Hrs
Oil Level/Quality	X					
Oil Leaks	X					
Water Leaks	X					
Belts, Pulley		X				
Plumbing		X				
Recommended Spare Parts						
Oil Change See page 2			X	X		
Plunger Packing Kit (1 kit/pump) See above					X	
Oil Seal Kit (1 kit/pump) See above					X	
Valve Repair Kit (1 kit/pump) See above						X

CP218/CP220/CP230-5123 Pump Repair Instructions

CAUTION EPDM o-rings must not come into contact with mineral oil or mineral grease. Use silicone grease only.

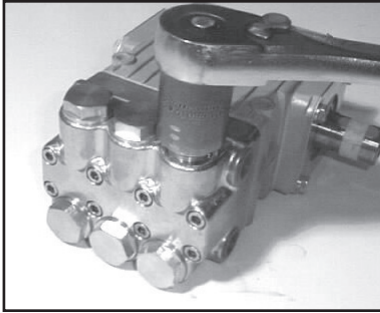

1. With a 22mm socket wrench, remove the (3) discharge valve plugs and (3) inlet valve plugs (32). Inspect the o-ring (33) for wear and replace if damaged.

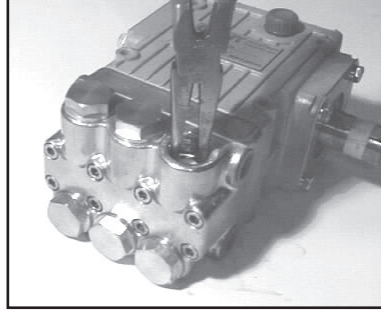

2. Using a needle nose pliers, remove the inlet and discharge valve assemblies (27-30). Inspect all parts for wear and replace as necessary.

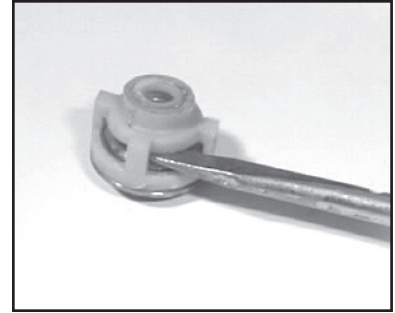

3. By inserting a small screw driver between the valve seat (27) and the valve spring retainer (30), the valve assembly can be separated.

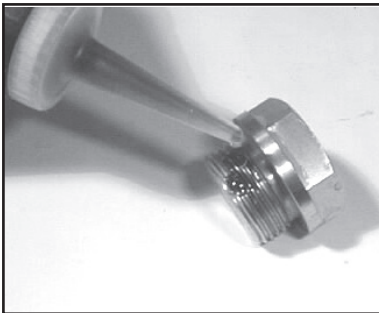

4. Apply one drop of Loctite 243 to the valve plugs (32) and tighten to 55 ft.-lbs. (75 Nm).

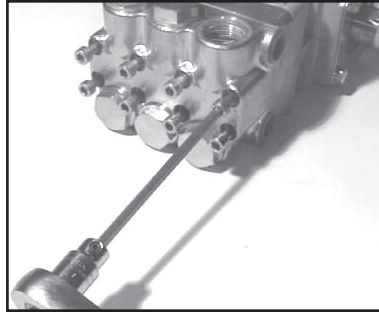

5. Next, use a 5mm allen wrench to remove the 8 socket head cap screws (34).

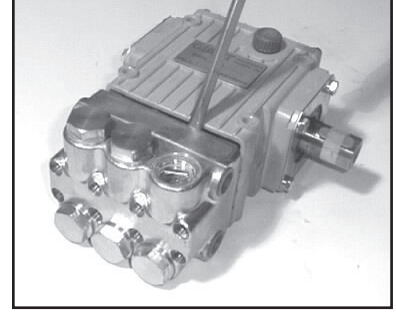

6. Carefully slide the valve casing (26) out over the plungers.

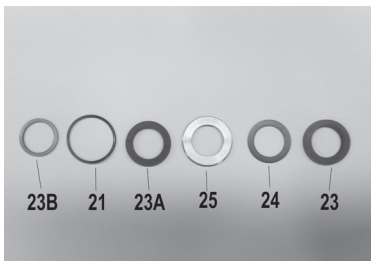

7. Remove the weep return ring (25), pressure ring (24), and v-sleeve (23) from the valve casing (26). Remove the rear v-sleeve (23A) and drip shield (23B) from the seal case (20). Inspect all parts, including o-ring (21) for wear and replace as necessary.

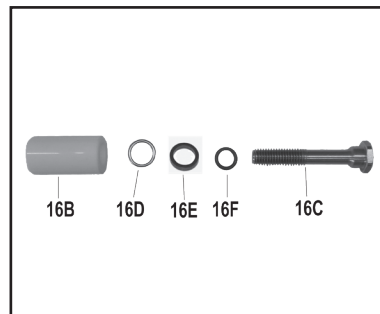

8. Check surfaces of plunger pipe (16B). A damaged surface will cause accelerated wear on the seals. Deposits of any kind must be carefully removed from the plunger surface. A damaged plunger must be replaced!



9. If the crankcase oil seals (19) are to be replaced, they can be removed by prying loose with a flat screwdriver. Take care not to make contact with the plunger.

CP218/CP220/CP230-5123 Pump Repair Instructions

Disassembly sequence of the gear end.

- 1) Before you begin, drain the oil from the crankcase.
- 2) Remove the crankcase cover (3) and O-ring (4) from the crankcase (1). To remove the crankshaft (13), remove the bearing cover (7) and sight glass (8). Using a rubber mallet, remove the crankshaft axially through the connecting rods by tapping on the end of the shaft. Be careful not to bend or damage the connecting rods during crankshaft removal.
- 3) If the bearings (12A and 12B) and radial shaft seal (11) are still in the crankcase, remove them. Inspect both bearings and seal for wear and replace if necessary.
- 4) Remove the connecting rod (15) and plunger assembly (16). Remove the wrist pin (17) if necessary. Check the plunger bore in the crankcase for wear. Inspect parts and replace as necessary.
- 5) Should you find it necessary to service the plunger assembly (16) you can do so by removing the tension screw (16C). Replace crush washer (16D).

NOTE: Carefully flatten crush washer before replacing it. Inspect all parts and replace as necessary.

Reassembly sequence of the CP217/CP218/CP220/CP230-5123 pumps.

- 1) Reassemble plunger assembly (16) (apply a drop of Loctite to the tension screw (16C) threads) and the connecting rod (15) with wrist pin (17). Place assemblies in crankcase (1). Install crankshaft through connecting rods again being careful not to bend or otherwise damage the connecting rods.
- 2) Replace left and right side bearings (12A and 12B) if they were removed from the crankshaft. Be certain the bearings are pressed all the way onto the shaft and completely into the crankcase. Replace radial shaft seal (11), bearing cover (7), sight glass (8), and crankcase cover (3) with its O-ring (4).
- 3) If oil seals (19) were removed, replace with seal lip towards crankcase. Lubricate seal before replacing.
- 4) Replace seal case (20) with O-rings (21) over plungers. Generously lubricate O-rings and oil seal before reassembly. Replace drip shield (23B) and v-sleeve (23A) over plungers (16).
- 5) Generously lubricate v-sleeve (23) and assemble into valve casing (26). Assemble weep return ring (25) and pressure ring (24) over plungers (16). Slide valve casing over plungers and seat firmly. Replace the eight socket head cap screws (34) and tighten to 106 inch-pounds (12 Nm) in a crossing pattern (**see below**).
- 6) Re-install the six O-rings (31) and the six valve assemblies (27-30). Now replace the six valve plugs with O-rings (32 and 33) and tighten securely with a 22mm socket wrench to 55 in-lbs. (75 Nm).
- 7) Fill crankcase with 8.1 ounces of oil.

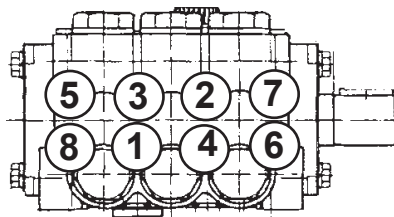

Pump Mounting Selection Guide

Bushings 01074 - 24 mm Tapered H Bushing
Pulley & Sheaves 01061 - 7.75" Cast Iron 1 gr. AB Section 01062 - 7.75" Cast Iron - 2 gr. AB Section
Rails 01160 - Plated Steel Channel Rails (L=5.75"x W=1.00"x h=2.50") 01161 - Plated Steel Channel Rails (L=5.75"x W=1.00"x H=2.50")

CP218/CP220/CP230-5123 Pump - Dimensions - inches (mm)

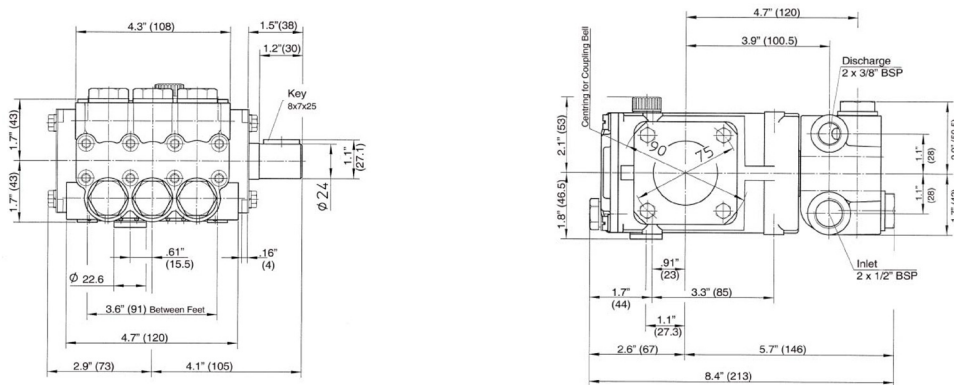

LIMITED WARRANTY

Eco₂Blast pumps and accessories are warranted by the manufacturer to be free from defects in workmanship and material as follows:

1. For portable pressure washers and car wash applications, the discharge manifolds will never fail, period. If they ever fail, we will replace them free of charge. Our other pump parts, used in portable pressure washers and in car wash applications, are warranted for five years from the date of shipment for all pumps used in NON-SALINE, clean water applications.
2. One (1) year from the date of shipment for all other Eco₂Blast industrial and consumer pumps.
3. Six (6) months from the date of shipment for all rebuilt pumps.
4. Ninety (90) days from the date of shipment for all Eco₂Blast accessories.

This warranty is limited to repair or replacement of pumps and accessories of which the manufacturer's evaluation shows were defective at the time of shipment by the manufacturer. The following items are NOT covered or will void the warranty:

1. Defects caused by negligence or fault of the buyer or third party.
2. Normal wear and tear to standard wear parts.
3. Use of repair parts other than those manufactured or authorized by Eco₂Blast.
4. Improper use of the product as a component part.
5. Changes or modifications made by the customer or third party.
6. The operation of pumps and or accessories exceeding the specifications set forth in the Operations Manuals provided by Eco₂Blast.

Liability under this warranty is on all non-wear parts and limited to the replacement or repair of those products returned freight prepaid to Eco₂Blast which are deemed to be defective due to workmanship or failure of material. A Returned Goods Authorization (R.G.A.) number and completed warranty evaluation form is required prior to the return to Eco₂Blast of all products under warranty consideration. Call (260)728-4433 to obtain an R.G.A. number.

Repair or replacement of defective products as provided is the sole and exclusive remedy provided hereunder and the MANUFACTURER SHALL NOT BE LIABLE FOR FURTHER LOSS, DAMAGES, OR EXPENSES, INCLUDING INCIDENTAL AND CONSEQUENTIAL DAMAGES DIRECTLY OR INDIRECTLY ARISING FROM THE SALE OR USE OF THIS PRODUCT.

THE LIMITED WARRANTY SET FORTH HEREIN IS IN LIEU OF ALL OTHER WARRANTIES OR REPRESENTATION, EXPRESS OR IMPLIED, INCLUDING WITHOUT LIMITATION ANY WARRANTIES OR MERCHANTABILITY OR FITNESS FOR A PARTICULAR PURPOSE AND ALL SUCH WARRANTIES ARE HEREBY DISCLAIMED AND EXCLUDED BY THE MANUFACTURER.



WARNING: This product might contain a chemical known to the State of California to cause cancer, and birth defects or other reproductive harm.

For more information go to www.P65Warnings.ca.gov



Sold Exclusively through **ECO₂Blast** 1025 W. Commerce Dr., Decatur, IN 46733
Phone: (260)728-4433 www.eco2blast.com
© Copyright 2020 ECO₂Blast