

Models

22188/22188-5100/

22189/22189-5100

Bottom Repairable Accumulators

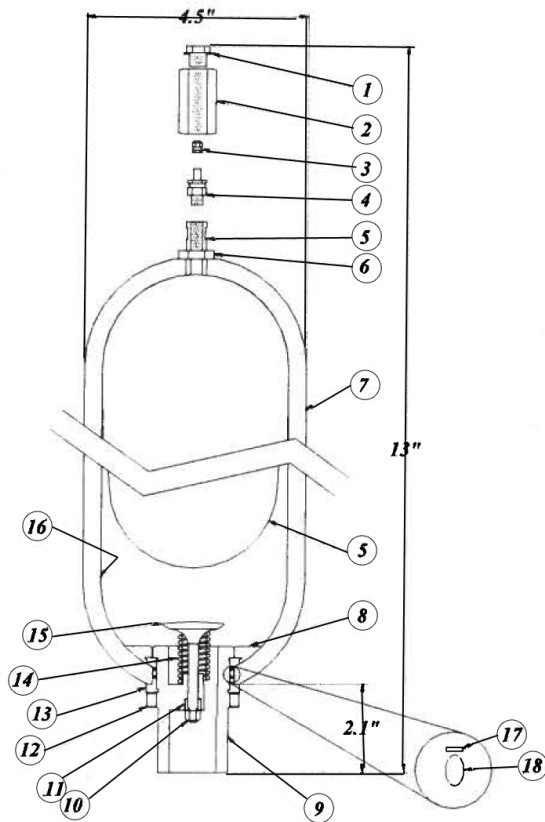

OPERATING SPECIFICATIONS

	U.S.	Metric
Maximum Pressure (22189):	3000 PSI	207 bar
Maximum Pressure (22188):	5000 PSI	350 bar
Maximum Temperature:	200 °F	93 °C
Maximum Pressure Precharge:	2500 PSI	172 bar
Connection:		3/4" FNPT
Weight:	9.5 lbs.	4.3 kg
Capacity:	1.0 Quart	0.95 L

WARNING: NEVER USE OXYGEN OR SHOP AIR!

This can be extremely dangerous and will void your warranty

*Note: It is the responsibility of the user to determine the proper pre-charge level to insure that pressure is maintained at all times. **In general pre-charge should equal 30% to 80% of the maximum system pressure.***

- ✓ Pre-charge with DRY NITROGEN (N₂) GAS ONLY!
- ✓ Never operate accumulator without nitrogen gas pre-charge.
- ✓ Release all system *hydraulic* pressure before attempting any maintenance or service.
- ✓ Follow all instructions.
- ✓ Wear proper eye protection.
- ✓ Wear steel toed shoes.
- ✓ Take proper safety precautions.

It is recommended that the accumulator be mounted pointing down as a safety precaution. This mounting procedure also allows the accumulator to remain cooler during system operation and prolongs the effective operating life of the accumulator bladder.

WARNING: Always fully discharge nitrogen pre-charge from bladder before attempting any repairs.

NEW ACCUMULATOR COMMISSIONING

Prior to operating a new accumulator on any system a few common sense steps should be taken

1. A qualified Fluid Power specialist should review the accumulator's application for correct sizing, pressure, cycling, connections, placement and efficiency.
2. Carefully remove the accumulator from the factory packaging, read and understand all factory labels, stickers, tags and nameplates attached to the accumulator and the packaging.
3. Read and understand any written factory instructions accompanying the accumulator.
4. If the accumulator is part of a third party OEM system, read and understands all of their labeling and instructions.
5. All the steps listed (above) should be followed.
6. The proper training of your accumulator maintenance personnel is recommended.

INSTALLATION & OPERATING INSTRUCTIONS

PRE-CHARGING INSTRUCTIONS

➤ **If the accumulator is already installed on a system:**

1. Pump a small amount of system fluid (10% of accumulator capacity) into the accumulator, at low pressure. (Do not exceed 35psi)
2. Turn off all power to the system and release all hydraulic pressure from the accumulator.

➤ **If accumulator is not yet installed:**

1. Place a small amount of fluid (10% of accumulator capacity) into the accumulator. Lubricate as much of the bladder surface area as possible.
2. Remove the protective cap (gas valve guard) and the valve cap (if there is one).
3. Attach the gland & nut portion of the charging assembly. If the gland & nut do not fit, you are using the wrong gas or wrong pressure!
4. Attach the air chuck to the accumulator bladder gas valve by hand tightening its swivel hex connection.
5. Turn the air chuck – “ T ” handle clockwise until it stops. This opens the valve core.
6. Set nitrogen bottle gas regulator (if attached) to 35 psig. (The use of a nitrogen gas regulator is strongly recommended!)
7. Open nitrogen bottle gas valve. (If you are not using a nitrogen gas regulator, care should be taken to slowly “crack” the valve open.) With a regulator, valve can be opened fully.
8. Pre-charge slowly (35 psig) using dry nitrogen gas, until bladder is fully inflated.

**CAUTION: INITIAL PRE-CHARGING AT A FLOW RATE ABOVE 35 PSIG
WILL CAUSE THE BLADDER TO BURST**

1. Continue pre-charging to desired pressure by increasing gas flow **slowly**.
2. Turn the air chuck “ T ” handle COUNTER-clockwise until it stops. This CLOSSES the valve core.
3. Remove the charging assembly. Check for gas leakage. (The use of gas leak detection fluid or soapy water is recommended.)
4. Tighten hex jam nut and lock nut fully.
5. Replace the valve cap, protective cap and ACC.INC nameplate. Tighten, hand tight.
6. Install accumulator on system. **CHECK FOR LEAKAGE.**
7. Pressurize system. Operate.

CAUTION: PRE-CHARGE MAINTENANCE

For cycling applications check the pre-charge weekly. For non-cycling applications, monthly. You will normally lose some gas, over time, due to Permeance. A more rapid loss may indicate a gas valve problem.

1. Release system pressure. Not gas pre-charge.
2. Remove gas protective cap (valve guard) and valve cap.
3. Install gauging device on gas valve stem.
4. Screw down air chuck “T” handle, check pressure.
5. Add additional **dry nitrogen gas** if necessary, using the above procedures.
6. To release excess nitrogen gas (if any) open up bleeder valve, located at bottom gauging device, until desired is achieved.

GIANT

Performance Under Pressure

Giant Industries, Inc.

900 N. Westwood Ave., Toledo, Ohio 43607

419-531-4600 Fax: 419-531-6836

www.giantpumps.com



WARNING: This product might contain a chemical known to the State of California to cause cancer, and birth defects or other reproductive harm.

For more information go to www.P65Warnings.ca.gov