

K 18000-3G Triplex Plunger Pump

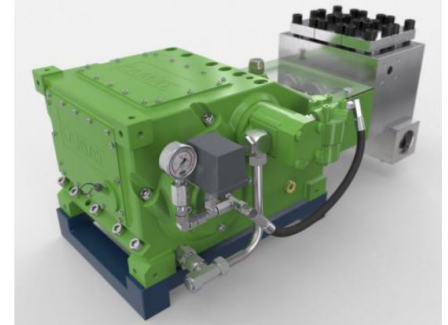
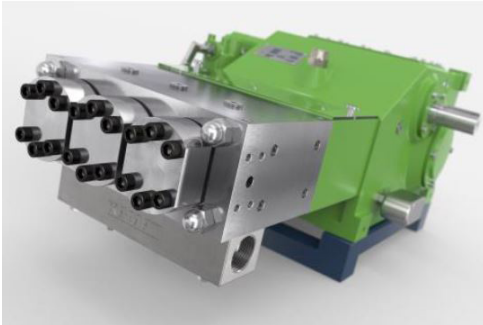

Rated Speed 500 RPM			Pressure at specific power inputs								Pump Head Style		
Type	FLOW		147 Hp	110 kW	174 Hp	130 kW	214 Hp	160 kW	241 Hp	180 kW	A	M	MC
	GPM	L/min	PSI	Bar	PSI	Bar	PSI	Bar	PSI	Bar			
K 18014-3G	6.3	24	34800	2400	41905	2890	50750	3500	--	--	1		
K 18016-3G	8.5	32	26680	1840	32045	2210	38860	2680	43645	3010	1		
K 18018-3G	10.6	40	21170	1460	25230	1740	30740	2120	34220	2360	1		
K 18020-3G	12.9	49	17255	1190	20590	1420	24868	1715	27695	1910	1		
K 18022-3G	15.9	60	14065	970	16965	1170	20590	1420	21750	1500	2		
K 18024-3G	18.8	71	11890	820	14210	980	17255	1190	19213	1325	2		
K 18026-3G	22.2	84	10005	690	12180	840	14790	1020	16385	1130	2		
K 18028-3G	25.6	97	8700	600	10440	720	12688	875	14138	975	2		H
K 18030-3G	29.3	111	7613	525	9135	630	11020	760	12325	850	2		H
K 18032-3G	33.6	127	6670	460	8048	555	9715	670	10875	750	2		H
K 18036-3G	42.3	160	5293	365	6308	435	7685	530	8555	590	2	1	H
K 18040-3G	52.3	198	4278	295	5148	355	6235	430	6888	475		1	1
K 18045-3G	66.1	250	3335	230	4060	280	4930	340	5438	375		1	1
K 18050-3G	81.6	309	2755	190	3263	225	3988	275	4423	305		1	1
K 18055-3G	98.8	374	2248	155	2755	190	3335	230	3625	250		1	1
K 18060-3G	117.6	445	1885	130	2320	160	2755	190	3045	210		1	1
K 18065-3G	137.9	522	1595	110	1958	135	2320	160	2610	180			1

■ =Ultra High Pressure

- ◆ Flow rate is based on 100% volumetric efficiency and 68° F (20° C) ambient temperature.
- ◆ Depending on fluid medium, a minimum inlet pressure is required.
- ◆ Depending on rod load, speed range is 10-100%.
- ◆ Gear dynamically balanced
- ◆ Gear with force-fed lubrication (at >175 Hp/130kW, oil cooler required)
- ◆ Standard Gear Ratios: i = 3.00, 3.14, 3.39, 3.76, 4.13, 4.50 and 4.93
- ◆ Weight: 970 lbs (440 kg)
- ◆ API 674 specifications available upon request. Maximum speed of 340 RPM
- ◆ Contact your local distributor or Giant Industries for use with special mediums. i.e. seawater, glycol, methanol, oil, etc.

Pump Dimensions mm(in)

High Pressure Head A

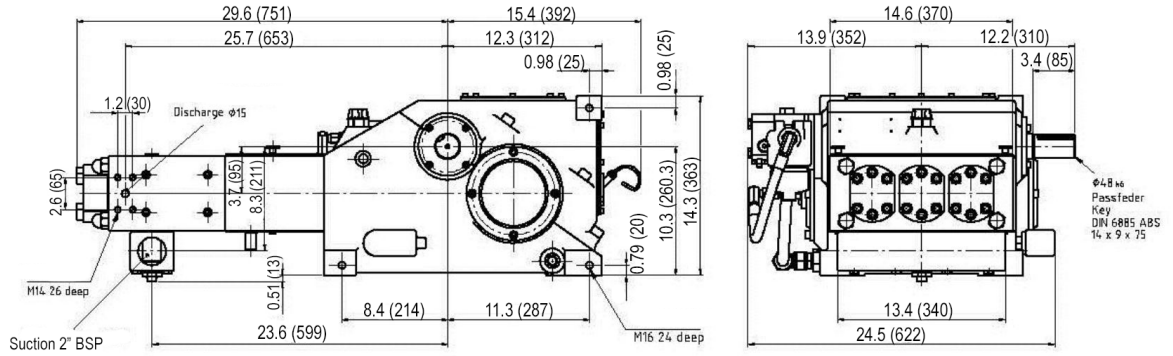

Compact Head M

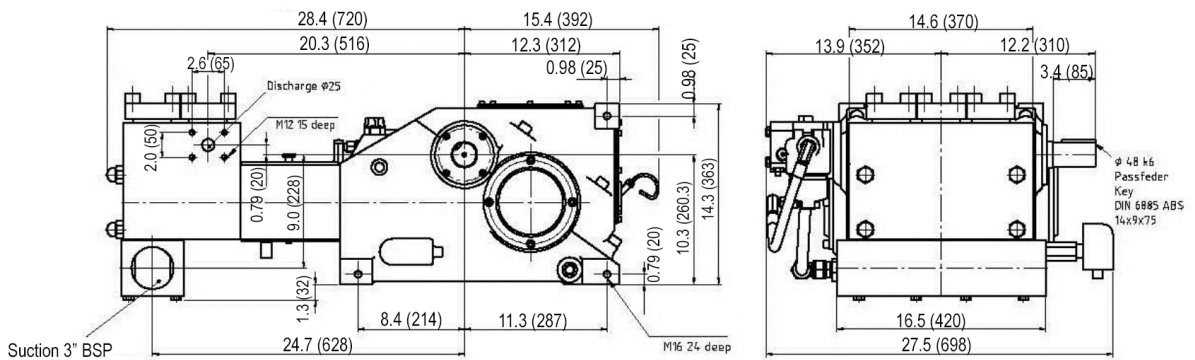

Compact Head (Low Pressure) MC
MCH Head

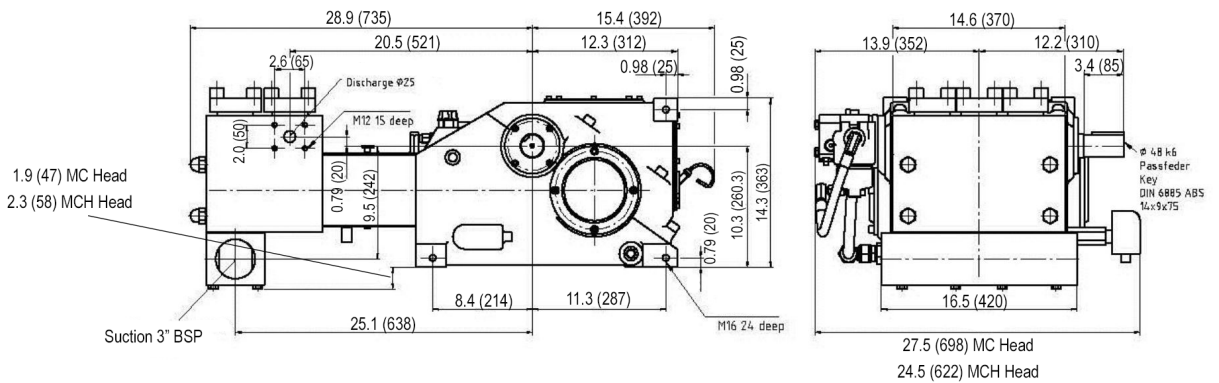

GIANT

Performance Under Pressure

GIANT INDUSTRIES, INC.

900 N. Westwood Ave. Toledo, Ohio
43607

Phone: (419) 531-4600

Fax: (419) 531-6836

www.giantpumps.com

© Copyright 2019 Giant Industries, Inc.

High Pressure
Head A

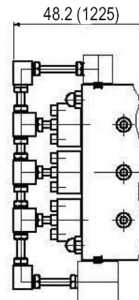

High Pressure Head ≥ 1500 bar

Footprint

