

# Series 23800

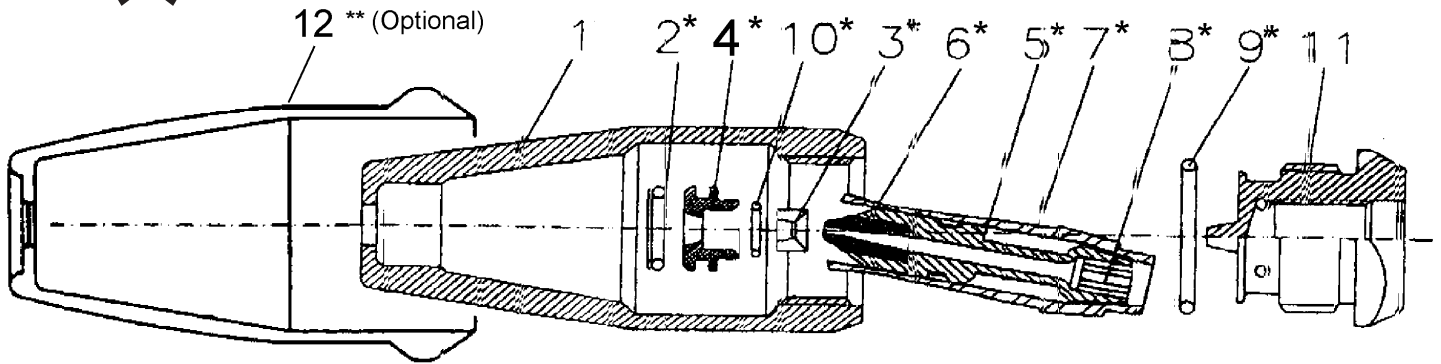

**23800-XX = Turbo Nozzle without cover**  
**23800-XXC = Turbo Nozzle with cover sizes**



\* Denotes parts in kit

### Parts List

Item	Part#	Description	Quantity
1	06639	Discharge Casing	1
11	06640-XX*	Drive Plug	1
12**	06219	Front Cap	1

\* This p/n corresponds to nozzle size, e.g. a 23800-20 turbo nozzle will have a 6640-20 drive plug.

\*\*For 23800 Series with Cover

### MAINTENANCE NOTICE:

If turbo will not spin, take unit apart and clean the nozzle.  
 If turbo still will not spin, have an authorized distributor repair nozzle.

### Repair

Repair	Kits#
9511-20	(23800-20)
9511-25	(23800-25)
9511-30	(23800-30)
9511-35	(23800-35)
9511-40	(23800-40)
9511-45	(23800-45)
9511-55	(23800-55)
9511-60	(23800-60)
9511-65	(23800-65)
9511-70	(23800-70)
9511-75	(23800-75)
9511-80	(23800-80)
9511-90	(23800-90)
9511-100	(23800-100)
9511-120	(23800-120)

### Nozzle

Nozzle	Includes
2.0	2-10
2.5	2-10
3.0	2-10
3.5	2-10
4.0	2-10
4.5	2-10
5.5	2-10
6.0	2-10
6.5	2-10
7.0	2-10
7.5	2-10
8.0	2-10
9.0	2-10
10.0	2-10
12.0	2-10

### Operating Conditions

Continous Pressure:	3200PSI
Maximum Pressure:	3600PSI
Maximum Temperature:	195 ° F
Angle:	20°
Weight:	0.7 lbs.
Inlet:	1/4" BSP



**Giant Industries, Inc.**

900 N. Westwood Ave.

Toledo, Ohio 43607

PHONE: 419-531-4600

FAX: 419-531-6836

www.giantpumps.com

© Copyright 2006 Giant Industries, Inc.



# SERIES 23800 TURBO LASER REPAIR INSTRUCTIONS

Before repairing the turbo laser, please note that item number (11) is not interchangeable with different size nozzles. Part #6640-XX corresponds to a specific nozzle size (see note on front page).

- 1) Secure discharge casing (1) and remove drive plug (11) with a 24mm wrench. Check o-ring (9) for damage and replace if necessary.
- 2) Remove rotor assembly (5-8). Make sure strainer (8), rotor (5), and "jet-hole" in drive plug (11) are free of obstructions. If necessary, replace with new assembly from kit.
- 3) Using a 5/16" wooden dowel rod, press out seat retainer (4), ceramic seat (3), and o-rings (2 & 10). If cracked or worn, replace with items found in kit.
- 4) To reassemble, press seat retainer (4), ceramic seat (3), and o-rings (2 & 10) into the top of the discharge casing (1). Make sure it is firmly seated at the top. Replace rotor assembly (5-8) and drive plug (11) with o-ring (9). Tighten securely.
- 5) Gently shake the nozzle to ensure movement of rotor assembly (5-8).