

Models

Pneumatic Unloaders

22980P, 22981P & 22982P



Construction Characteristics

- Compact Size
- Body made with Special Brass
- Interchangeable Valve Seats
- Constant Pressure with multi-spray gun operating
- Connections for Pressure Gauge

Performance Chart

Model	Operating Pressure		Min. Flow Rate		Max. Flow Rate		Water Temperature	
	PSI	Bar	GPM	L/min	GPM	L/min	°F	°C
22981P	0-2200	0-150	2.1	8.0	79.3	300	150	70
22982P	0-3000	0-180	2.1	8.0	79.3	300	150	70
22980P	0-7250	0-500	2.1	8.0	26.4	100	150	70

IMPORTANT!

- **Observe the direction of the flow. NEVER close or fit the bypass with a shut-off device.**
- **Continual bypass operation without releasing the water can cause the liquid to heat up, damaging the unit and endangering people.** To prevent this from happening, limit the bypass duration (note the max. temperature), and calculate the duration in conjunction with the operating conditions. Use fittings (e.g. thermal valve on water inlet) to avoid heat increase.

OPERATION

- The entire flow must pass through the valve. Compressed air is admitted into the unloader cylinder via a pneumatic governor.
- The water pressure reacts proportionally to the adjusted air pressure. Therefore, the unloader is optimally suited for keeping pressure at a constant level when one pump is connected to several discharge points (spray guns).
- When terminals (spray guns) are shut off, the valve switches to pressure free bypass operation.

PERFORMANCE

The bypass line must be laid in a flow-favorable way.

The cross-section of the bypass line must at least correspond to the outlet cross-section of the valve.

Outlet (BSP+NPT)	1/4	1/2	3/4	1
Min. ø (mm)	8	8	15	17

SAFETY INSTRUCTIONS

IMPORTANT! Observe the direction of flow. The bypass must under no circumstances be closed off or fitted with a shut-off device. The diameter of the bypass discharge port should not be reduced any further but increased instead (1" BSP or bigger). As the full amount of 79.3 GPM (300 L) causes very high flow speed, a large dimensioned and sturdy high pressure hose must be tightly fitted to the bypass (to avoid whip effect) – preferably in a straight down position. Elbow fittings after the bypass outlet are to be avoided. The line after the bypass should be constructed to allow for good flow without much resistance. The stagnation pressure between the pump and UNLOADER depends directly on the flow resistance present in the bypass line.

Continuous bypass operation without releasing the water can cause the liquid to heat up which in turn could damage the unit and endanger persons.

Possible preventive measures:

- 1.) Limit the bypass duration (maximum temperature 150 °F [70°C]); the duration is to be calculated by the operator in conjunction with the operating conditions.
- 2.) Use fittings to avoid heat increase (e.g. thermo valve on water inlet side).

22980P

<u>Item</u>	<u>Part #</u>	<u>Description</u>	<u>Qty.</u>	<u>Item</u>	<u>Part #</u>	<u>Description</u>	<u>Qty.</u>
1	08500	Casing	1	20	08520	Guide Ring	1
2	03053	Cylinder Adapter	1	21+	07392	Support Ring	1
3	07008	Inner Hexagon Screw	4	21A+	06718	Support Ring	1
4	03578	Cylinder Assembly	1	22+	07391	Grooved Seal Ring	1
4A	03579	Cylinder	1	22A+	06717	Grooved Seal Ring	1
4B	04036	Hexagon Nut	1	23+	08523	Valve Seat	2
4C	03580	Washer	1	24	08524	Valve Plug	2
4D	04635	Sleeve	1	25+	07489	O-Ring	2
4E	03581	Pressure Pin	1	26+	12057	O-Ring	2
6	04035	Inner Hexagon Screw	4	28	08530	Spacer Pipe	1
13	06714	Centering Disc	1	29+	08531	Valve Plate	1
14+	06687	Piston	1	30+	12216	Valve Spring	1
15+	06715	Seal Support	1	31	07423-0100	Plug	4
16+	06713	Hexagon Nut	1	32	06934	Copper Gasket	4
17	06716	Cylinder	1				
18+	12004	O-Ring	1				
19	08519	Spacer Ring	1				
				*09543		Repair Kit	

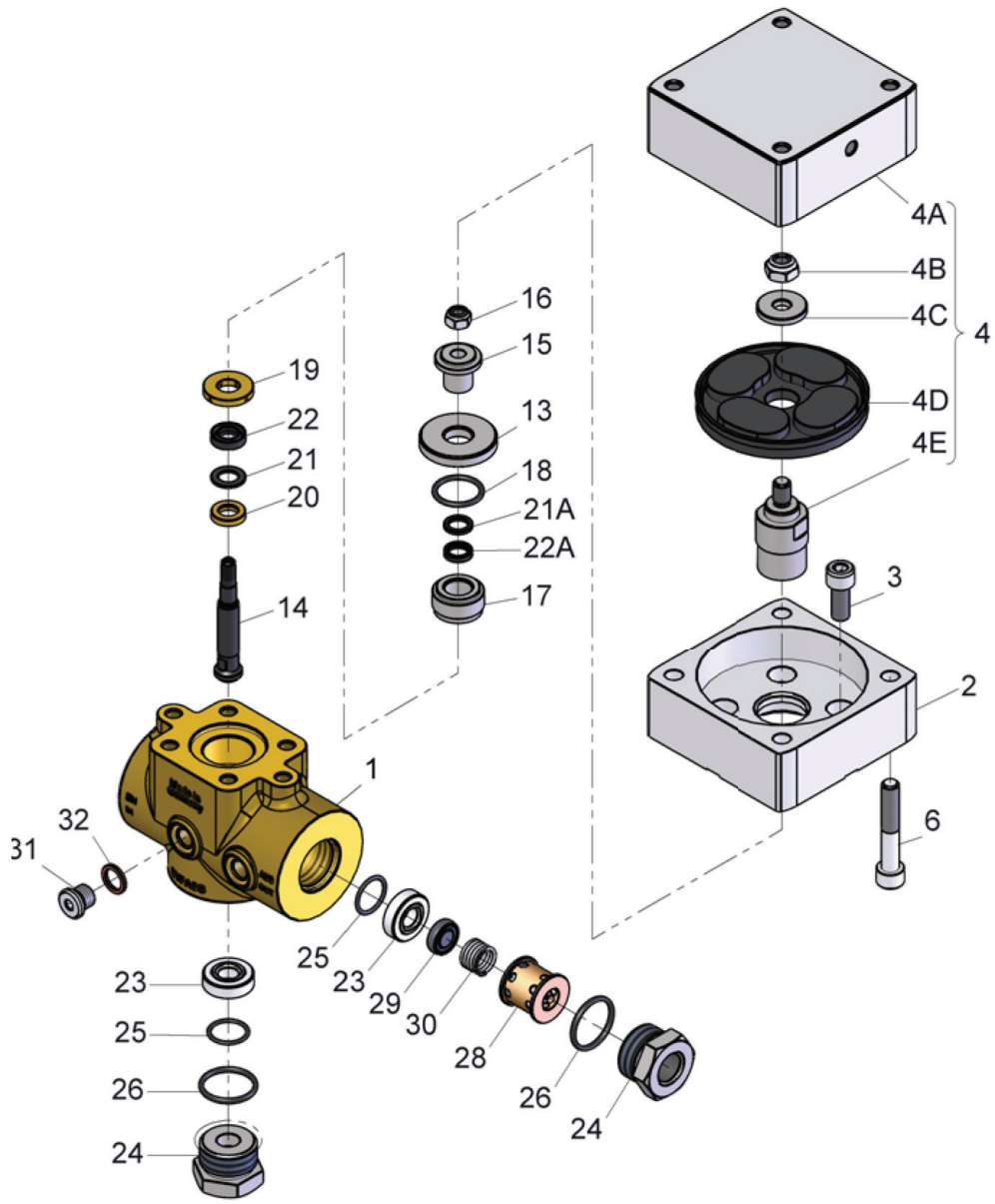

22981P

<u>Item</u>	<u>Part #</u>	<u>Description</u>	<u>Qty.</u>	<u>Item</u>	<u>Part #</u>	<u>Description</u>	<u>Qty.</u>
1	05512	Casing	1	20A	07281+	O-Ring	1
2	03053	Cylinder Adapter	1	21	07840+	Support Ring	1
3	07008	Inner Hexagon Screw	4	21A	13253+	Support Ring	1
4	03578	Cylinder Assembly	1	22	13254+	Seal Packing	1
4A	03579	Cylinder	1	22A	13255+	Seal Packing	1
4B	04036	Hexagon Nut	1	23	13256+	Valve Seat	2
4C	03580	Washer	1	24	05724	Bypass Valve Plug	1
4D	04635	Sleeve	1	25	12057+	O-Ring	2
4E	03581	Pressure Pin	1	26	12055+	O-Ring	1
6	04035	Inner Hexagon Screw	4	28	05725	Kick-Back Valve Plug	1
13	05625	Centering Disc	1	28A	13259	Spacer Pipe	1
14	13247+	Piston	1	28B	07653+	O-Ring	1
15	13248+	Seal Support	1	29	13260+	Valve Plate	1
16	04036	Hexagon Nut	1	30	07750+	Valve Spring	1
17	05628	Cylinder	1	31	07423-0100	Plug	4
18	13012+	O-Ring	1	32	06934	Copper Gasket	4
19	05709	Spacer Ring	1				
20	05643	Guide Ring	1	+09704		Repair Kit	

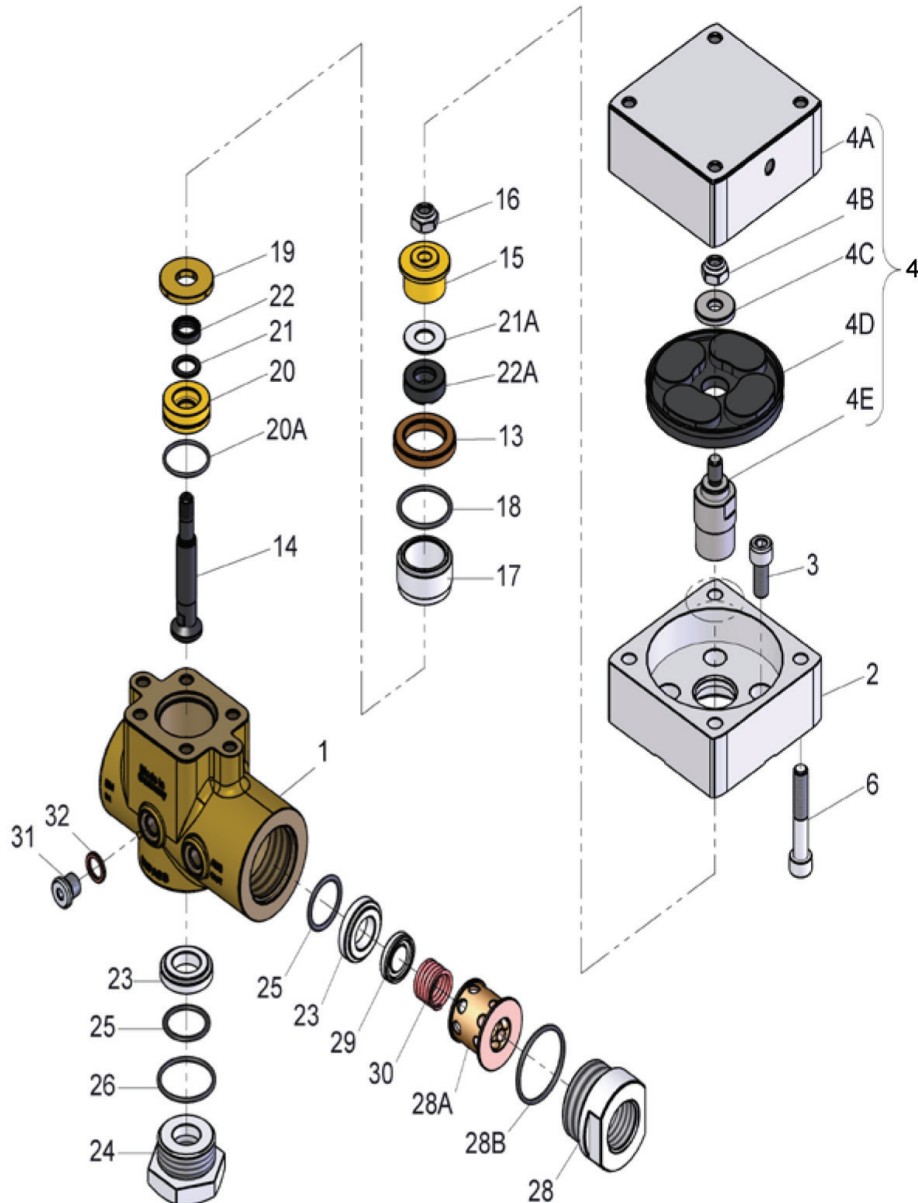

22982P

<u>Item</u>	<u>Part #</u>	<u>Description</u>	<u>Qty.</u>	<u>Item</u>	<u>Part #</u>	<u>Description</u>	<u>Qty.</u>
1	05512	Casing	1	21	07840+	Support Ring	1
2	03053	Cylinder Adapter	1	21A	07904+	Support Ring	1
3	07008	Inner Hexagon Screw	4	22	13254+	Seal Packing	1
4	03578	Short Stroke Cylinder	1	22A	08087+	Seal Packing	1
4A	03579	Cylinder	1	23	13256+	Valve Seat	1
4B	04036	Hexagon Nut	1	23A	03054+	Valve Seat	1
4C	03580	Washer	1	24	05724	Bypass Valve Plug	1
4D	04635	Sleeve	1	25	12057+	O-Ring	2
4E	03581	Pressure Pin	1	26	12055+	O-Ring	1
6	07773	Inner Hexagon Screw	4	28	05725	Kick-Back Valve Plug	1
13	05703	Centering Disc	1	28A	13259	Spacer Pipe	1
14	13247+	Piston	1	28B	07653+	O-Ring	1
15	05704+	Seal Support	1	29	13260+	Valve Plate	1
16	04036	Hexagon Nut	1	30	07750+	Valve Spring	1
17	05705	Cylinder	1	31	07423-0100	Plug	4
18	13012+	O-Ring	1	32	06934	Copper Gasket	4
19	05709	Spacer Ring	1				
20	05643	Guide Ring	1				
20A	07281+	O-Ring	1				
				*09705	Repair Kit		

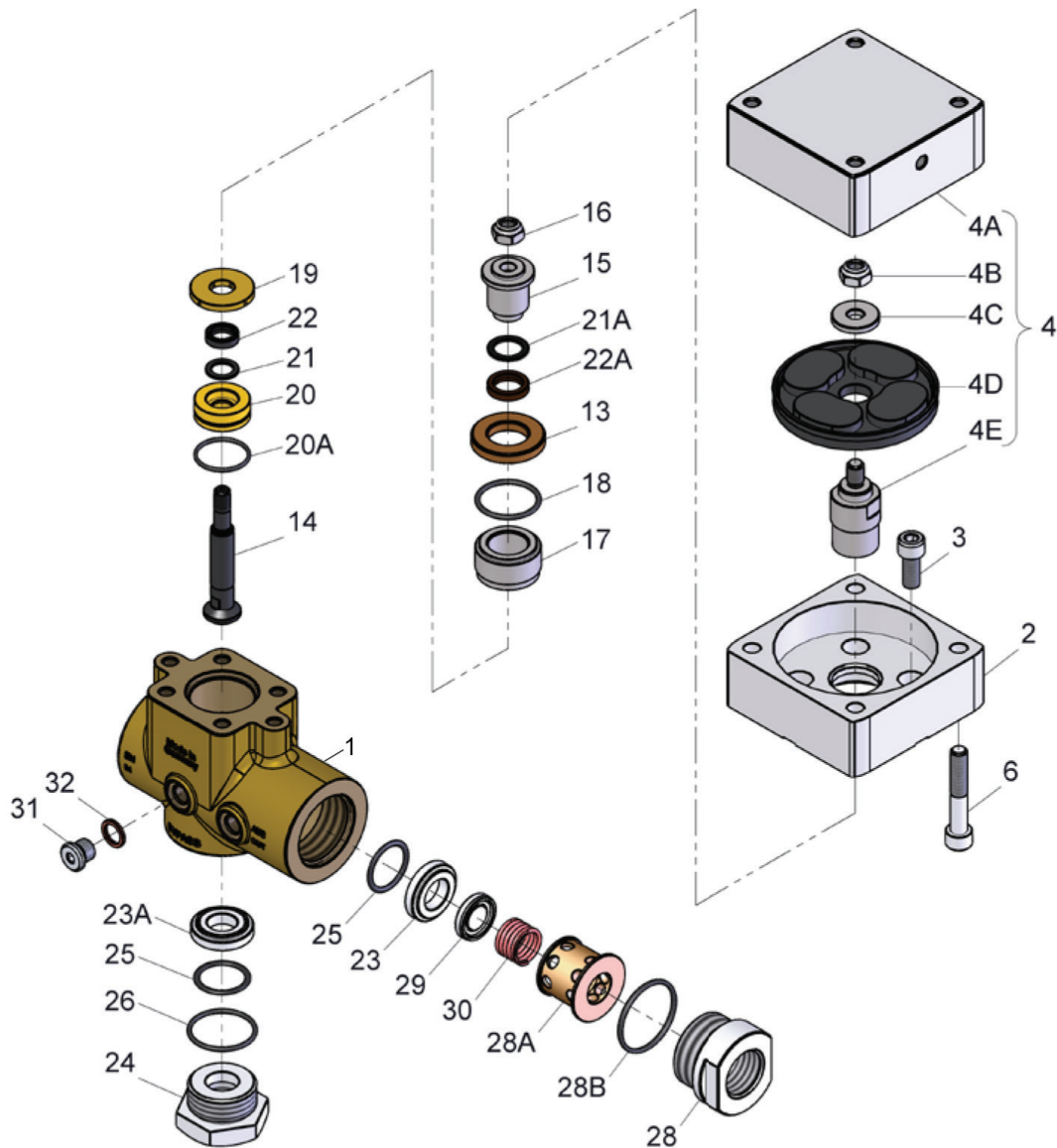

INSTALLATION AND ADJUSTMENT OF PRESSURE

The valve is installed in the discharge line and should be close to the discharge outlet of the high pressure pump. If there is considerable flow rate or plunger displacement, we recommend fitting a pressure accumulator between the high pressure pump and the unloader valve to dampen pump pulsation.

Version 1: The compressed air is adjusted to the desired pump pressure via a pneumatic governor without a kick-back valve.

An air pressure of 87 PSI (6 Bar) corresponds to approximately 7612 PSI (525 Bar) of water pressure on the 22980P, and 1450 PSI (100 Bar) of water pressure on the 22981P and 22982P. Slight difference in these values can arise due to pulsation (see chart below).

22980P, 22981P & 22982P Air Pressure Chart							
		22980P		22981P		22982P	
Air Pressure		Liquid Pressure		Liquid Pressure		Liquid Pressure	
PSI	Bar	PSI	Bar	PSI	Bar	PSI	Bar
14.5	1	1100	75			362.5	25
29	2	2175	150	290	20	725	50
43.5	3	3262	225	580	40	1087	75
58	4	4350	300	864	60	1450	100
72.5	5	5438	375	1160	80	1812	125
87	6	6525	450	1450	100	2175	150
101.5	7	7612	525	1740	120	2538	175
116	8			2030	140		
130.5	9			2320	160		

IMPORTANT! To prevent pump overload, install and adjust the safety valve to the maximum operating pressure. Additionally, install an adjusted safety valve in the compressed air line to ensure that the admissible operating pressure of the unloader valve cannot be exceeded in the case of incorrect adjustment of the air pressure relief unit.

When several spray guns are being used, the preset air pressure ensures that the discharge pressure on the spray guns always remains consistent and even. The unloader switches to pressure-free bypass operating when the last gun is closed. The discharge pressure between the unloader and guns remains (see configuration sketch on next page)

Version 2 An addition to version 1 is installing a flow indicator in the discharge line after the unloader. Remove the unloader valve plate (29) and valve spring (30), and install a 3/2 way solenoid valve (e.g., Festo 7803 MFH-3-1/8, min. air pressure of 43.5 PSI or (3 bar) in the compressed air line.

At zero flow (all guns closed), the flow indicator will switch the solenoid valve so the piston unit in the unloader becomes pressure-free. When the unloader switches to pressure-free bypass, the pressure lines between the unloader and guns are also become pressure-free. This puts less strain on the pump and unit parts, reducing wear. Pressure on the guns will build gradually (see configuration sketch).

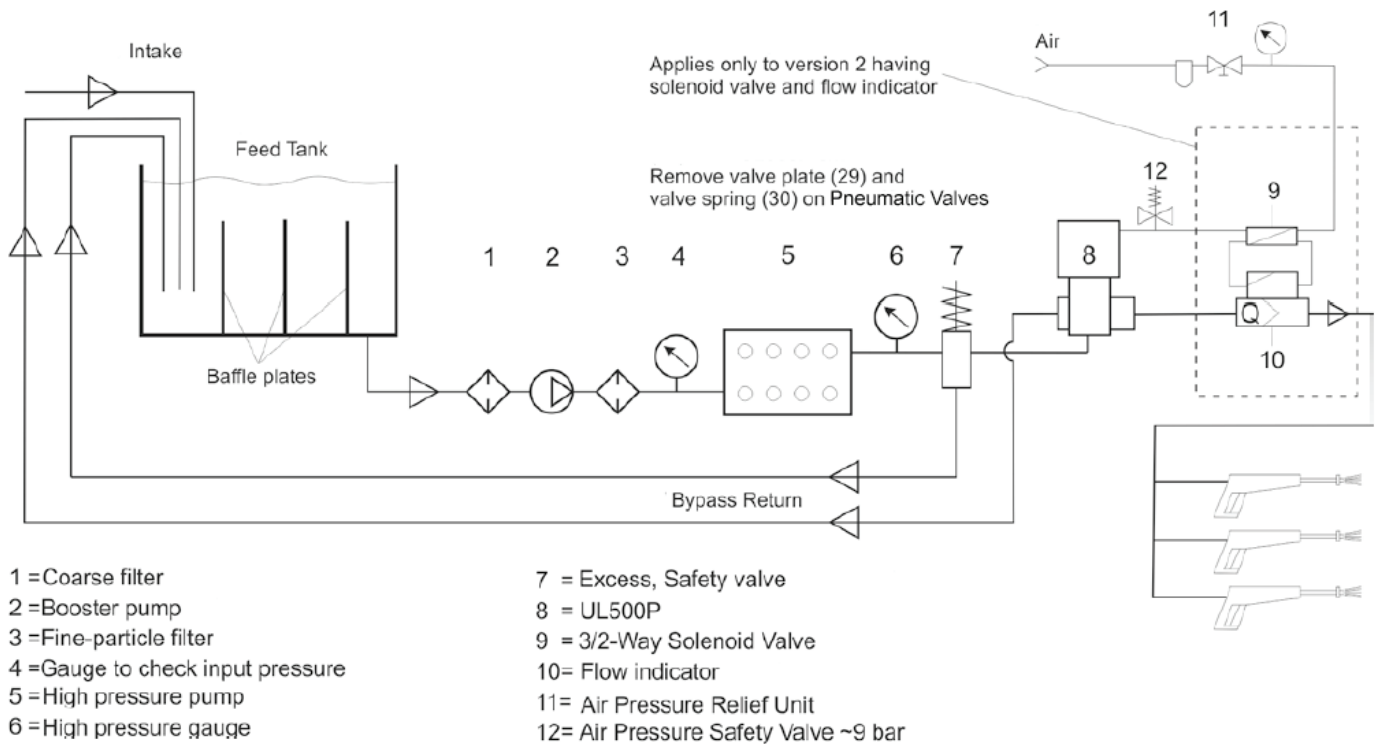

SERVICE AND ADJUSTMENT

These procedures are only to be carried out by qualified personnel.

To RENEW PISTON SEALS

Unscrew the inner hexagon screw (6) and remove short-stroke cylinder (4). After unscrewing inner hexagon screw (3), remove cylinder retainer (2) from casing (1).

Push out complete piston assembly (13-22A) upwards. Hold piston (14) with size 12 spanner wrench and remove hexagon nut (16). Remove cylinder (17), seal support (15), spacer ring (19) and seal retainer (20)-22981P/22982P or guide ring (20)-22980P together with seals from the piston (14). Take note of the sequence for reassembling. Check inner cylinder surface (17) and piston surface (14). Check seals and replace as necessary. Dirt or damage will cause seals to wear out quickly. Grease all parts lightly with silicone before reinstalling. Tighten hexagon nut (16) to 177 in.-lbs. (20NM)

Center bypass valve seat (23 or 23A) within casing and tighten to 110 ft.-lbs. (150 NM) with valve plug (24). Next, insert complete piston unit from the top. Fit cylinder adapter (2) on to the casing (1) with inner hexagon screws (3) to 33 ft.-lbs. (45 NM).

Mount short-stroke cylinder (4) with screwed-in compression cap (5) onto cylinder adaptor (2). Tighten inner hexagon screws (6) to 33 ft.-lbs. (45 NM).

To CHECK AND REPLACE VALVES

Screw out plugs (24 and 28) and pull out spacer pipe (28A-22981P/22982P or 28-22980P) underneath plug (28-22981P/22982P or 24-22980P). Check whether the valve plate (29) underneath or the piston (14) is worn out. Remove the valve seats (23 or 23A) and check the surfaces and O-rings for wear and/or damage. Replace as necessary.

Troubleshooting Guide		
Defect	Cause	Remedy
Valve switches repeatedly when gun is closed	Leaky Gun	Renew gun
	Leaky Pressure Pipe	Seal pressure pipe
	Leaky seal (22)	Renew seal
	Worn out non-return valve	Check and renew as necessary valve plate, O-ring and seat
	Leaky seal (18)	Renew Seal
Gauge shows high pressure peaks when shutting off gun	Air pressure is too high	Reduce air pressure
	Dirty Valve	Clean valve (removing deposits, etc.). Grease parts before reinstalling

22980P Dimensions - Inches (mm)

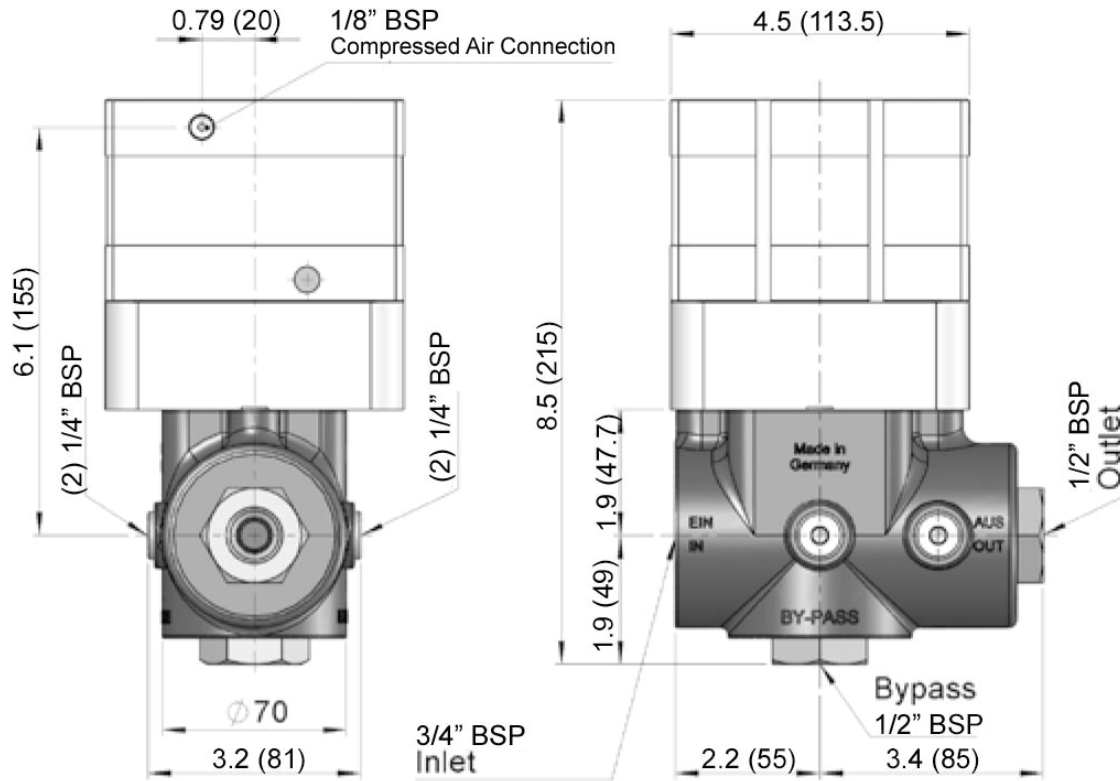

22981P & 22982P Dimensions - Inches (mm)

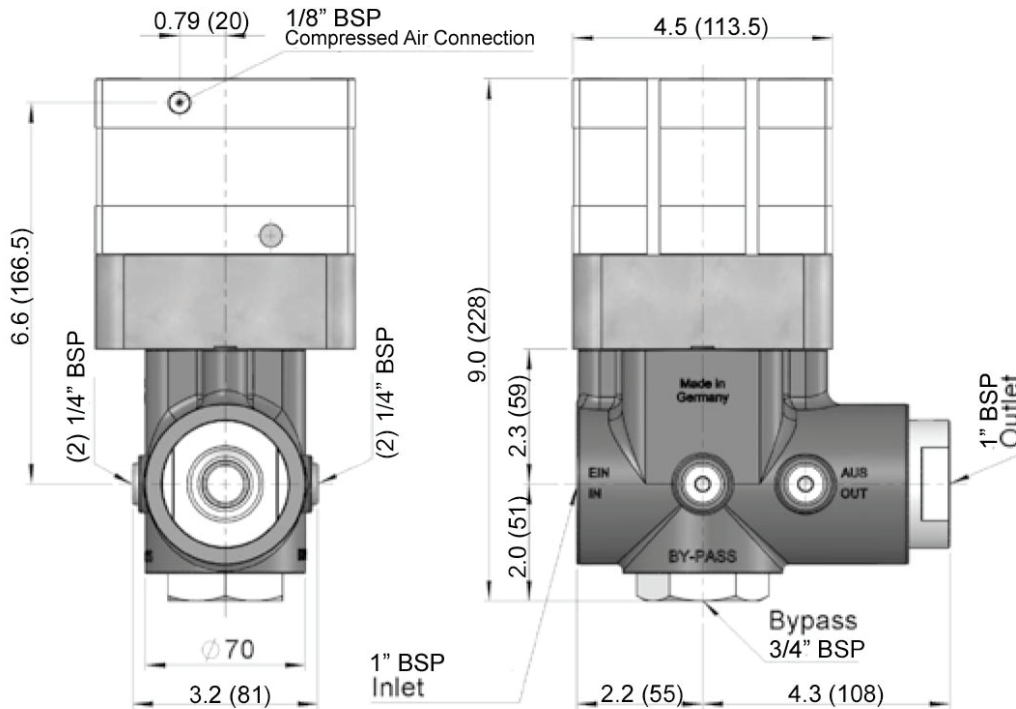

WARNING: This product might contain a chemical known to the State of California to cause cancer, and birth defects or other reproductive harm. For more information go to www.P65Warnings.ca.gov

GIANT
Performance Under Pressure

Giant Industries, Inc.

900 N. Westwood Ave., Toledo, Ohio 43607

Phone: 419-531-4600 Fax: 419-531-6836

www.giantpumps.com

© Copyright 2023 Giant Industries, Inc.