

Models

22980-30 Unloader

22980R-30 Regulator (High Pressure)

Item	Part#	Description	Qty
1	06879	Casing	1
2	04612	Spring Guide	1
2A	04613	Flange for Spring Guide	1
3	07381	Inner Hexagon Screw	4
4	08503	Inner Hexagon Screw	1
5	08504	Stud Bolt	1
6	08505	Hand Wheel	1
7	08506	Hexagon Nut	3
7A	08882	Washer	2
8	08507	Disc	2
9	08508	Bearing Part I	1
10	12323	Axial Bearing	1
11	08510	Bearing Part II	1
12	12218	Spring Plate	18
13	06714	Centering Disc	1
14	06687	Piston	1
15	06715	Seal Support	1
16	06713	Hexagon Nut	1

Item	Part#	Description	Qty
17	06716	Cylinder	1
18	12004	O-Ring	1
19	06719	Spacer Ring	1
20	06720	Guide Ring	1
21	07392	Support Ring	1
21A	06718	Support Ring	1
22	07391	Seal Pack	1
22A	06717	Seal Ring	1
23	08523	Valve Seat	2
24	08524-NPT	Fitting, 1/2" NPT	2
24A	04610	Inlet Valve Fitting, 1" NPT	1
25	07489	O-Ring	2
26	12057	O-Ring	2
28	06887	Spacer Pipe (22980-30 Only)	1
29	08531	Valve Plate (22980-30 Only)	1
30	12216	Valve Spring (22980-30 Only)	1
31	07423-0100	Plug (not shown)	4
32	07755-0100	O-Ring (not shown)	4

Operating Specifications

	U.S.	Metric
Max. Pressure (2298R-30):	10,000 PSI	690 Bar
Max. Pressure (22980-30):	7250 PSI	500 Bar
Min. Pressure:	580 PSI	40 Bar
Max. Flow:	26 GPM	100 LPM
Min. Flow:	2.1 GPM	8 LPM
Max. Temperature:	190° F	88° C
Weight:	15.4 lbs.	7.0 kg
Inlet Port:	1" NPT	
Outlet Port:	1/2" NPT	
Bypass:	1/2" NPT	

Repair Kits:

Unloader Kit	Parts Included:
09567	14, 15, 16, 18, 21, 21A, 22, 22A, 23, 25, 26, 29, 30

Regulator Kit	Parts Included:
09568	14, 15, 16, 18, 21, 21A, 22, 22A, 23(1), 25(1), 26(1)

GIANT

Performance Under Pressure
Giant Industries, Inc.

900 N. Westwood Ave.
Toledo, Ohio 43607
419-531-4600
FAX 419-531-6836
www.giantpumps.com

© Copyright 2022 Giant Industries, Inc.

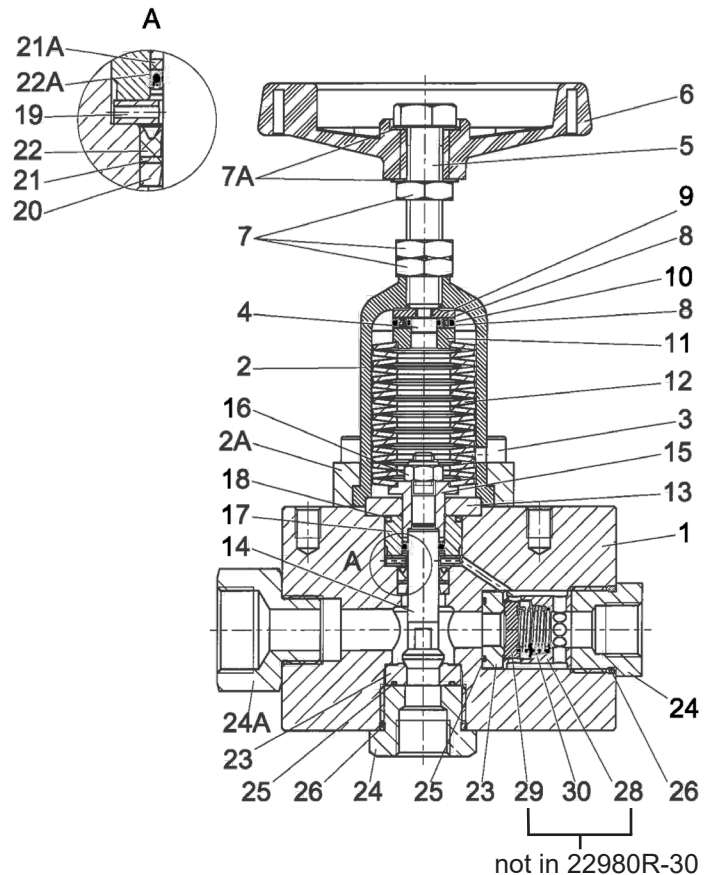

SERVICE AND ADJUSTMENT

Servicing and adjusting work is only to be carried out by a skilled tradesman.

TO RENEW THE PISTON ROD SEALS AND SLEEVES

Relieve the spring pack by means of the hand wheel (6). Screw out the four inner hexagon screws (3). Remove the spring guide (2) along with the spring plates (12) and hand wheel. **CAUTION: The hexagon nuts (7) are not to be shifted from the set position. These are the locking nuts to retain the maximum adjusting pressure.** Note the sequence of the spring plates (12) for reassembling. Push out complete piston assembly (13-22) over the bypass. Hold piston (14) with size 10 spanner and screw off hexagon nut (16). Take seals and cylinder along with the seal supports off the piston, taking note of the sequence for reassembling.

Check inner cylinder surface (17) and piston surface (14). Check seals and replace as necessary. Dirt or damage will cause seals to wear out quickly.

Grease all parts lightly with silicone before reinstalling. Tighten hexagon nut (16) to 36 ft.-lbs.

Center bypass valve seat within casing and tighten to 184 ft.-lbs. with valve plug (24). Next insert complete piston unit from the above side. Fit spring guide (2) along with spring plates (12), tighten inner hexagon screws (3) to 36 ft.-lbs.

TO CHECK AND REPLACE VALVES

Screw out plugs (24 & 28); pull out spacer pipe (28A) underneath plug (28). Check whether the valve plate (29) underneath or the piston (14) is worn out. Remove the valve seats (23) and check the surfaces for damage. Replace as necessary.

TO ADJUST PRESSURE

The spring packing is pre-tensioned by means of the hand wheel (6) while the pump is running and the gun is open (in the case of more than one gun, all guns have to be open) until required operating pressure is reached. This must allow for a residue of at least 0.13 GPM to flow over the bypass. The spring packing is never to be tensioned high enough to completely seal up the bypass. The hexagon nut (7) is then to be locked to the spring guide (2).

If the nozzle hole is too small, on no account is the valve to be adjusted to an operating pressure higher than that of the pump. It is advisable in this case to install nozzles more suitable for this purpose.

OPERATION

The whole discharge must be guided through the valve. Should the actual operating the actual operating pressure exceed the adjusted operating pressure, the valve then acts as a pressure regulator. The valve switches to pressure free bypass operation when the spray gun shuts off and the spray pressure between gun and valve remains idle.

The valve can be operated with a number of spray guns ; furthermore, more than one pump can be connected to the pressure pipe.

Valves are pre-adjusted to the desired operating pressure; therefore, the actual operating pressure has always to be stated when ordering.



WARNING: This product might contain a chemical known to the State of California to cause cancer, and birth defects or other reproductive harm. For more information go to www.P65Warnings.ca.gov

22980R-30 DIMENSIONS - inches (mm)

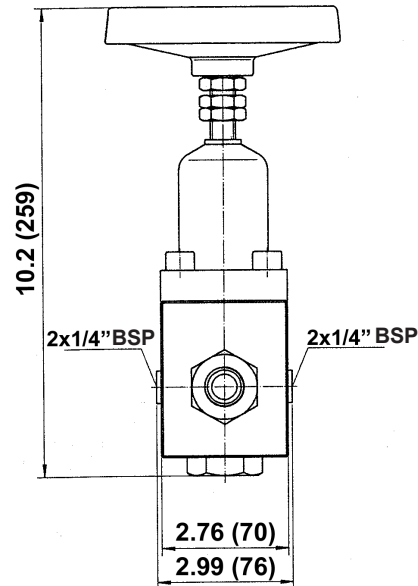
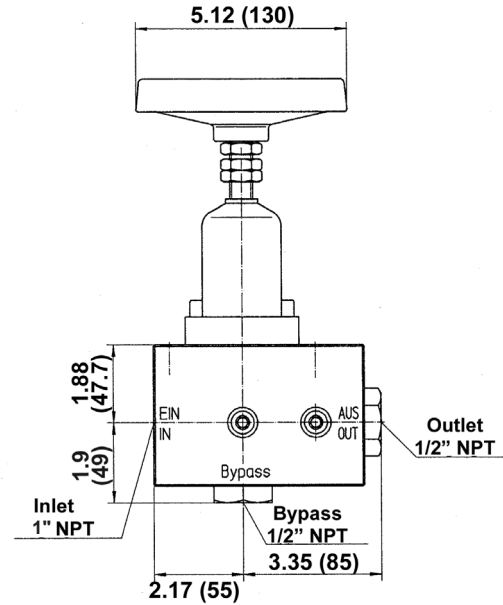

Defect	Cause	Remedy
Valve switches repeatedly when gun is closed	Leaky gun	Repair Gun
	Leaky Pressure Pipe	Seal Pressure Pipe
	Leaky Seal Pack (22)	Renew seal pack
	Worn out valve plate (29)	Check and replace valve plate (29) and seat(23)
	Leaky O-Ring (18)	Replace O-Ring (18)
Pressure gauge shows high pressure peaks when shutting off gun	Valve set too high above operating pressure	Turn back hand wheel (6)
	Dirty Valve	Clean valve (removing deposits etc.) Grease parts before reinstalling