

Models

Unloader/Regulator

22971C/22971CH/22971CR/22971CRH/

22973C/22973CH/22973CR/22973CRH/

22974/22974R

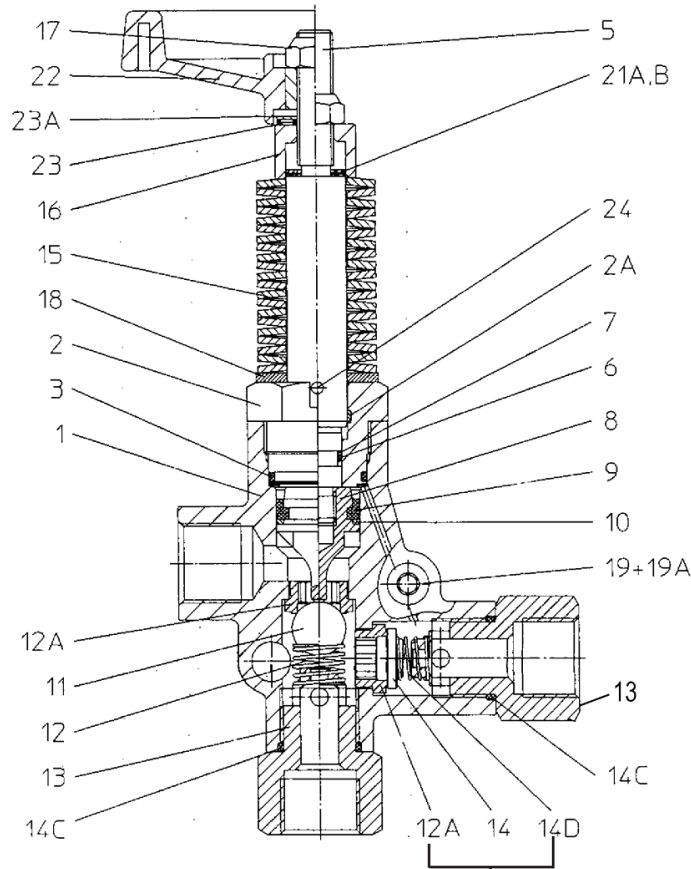

22971C/22973C/22974 = Unloader
22971CR/22973CR/22974R = Regulator

When ordering handwheel versions add "H" to model number

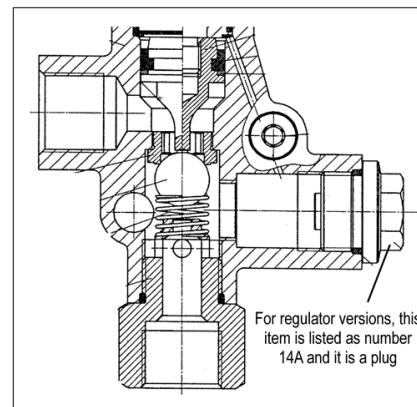

Not present in Regulator Versions

Item	Part #	Description	Qty.	Item	Part #	Description	Qty.
1	12232	Valve Body	1	14C	07035	O-Ring	2
2	12240	Guide Plug	1	14D	06017-0100	Spring, Outlet Valve (unloader versions)	1
2A	12241	Guide Ring	1	15	12218	Spring, Yellow (22971C)	21
3	12057	O-Ring	1	15	12220	Spring, Orange (22973C)	19
5	12242	Piston Rod	1	15	04284	Spring, Silver (22974)	23
6	12204	O-Ring, Valve Stem	1	16	12245	Spacer Sleeve	1
7	12205	Support Ring, Valve Stem	1	17	12246	Self-Locking Hexagon Nut	1
8	12206	Piston Body	1	18	12223	Washer, Spring	1
9	05005	Cup, 28mm	1	19	06685	Plug	4
10	05015	Support Ring, 28mm	1	19A	12017	O-Ring, Plug	4
11	12207	Ball	1	21A	06821	Spacer Disc, 0.5 mm	1
12	12216	Valve Spring	1	21B	06822*	Spacer Disc, 1.0 mm	3
12A	03402	Seat (unloader versions)	2	22	06774	Spoked Handwheel ("H" versions)	1
12A	03402	Seat (regulator versions)	1	23	06775	Axial Needle Bearing ("H" versions)	1
13	12243	Fitting (unloader versions)	2	23A	06776	Disc ("H" versions)	1
13	12243	Fitting (regulator versions)	1	24	12247	Serrated Pin	1
14	12244	Valve Plate (unloader versions)	1				
14A	06820	Discharge Plug (regulator versions)	1				

*May not be present

Repair Kit: Part Number Parts Included:

09461 2A, 3, 6, 7, 9, 10, 11, 12, 12A, 14, 14C, 14D, 19A

NOTE: This kit includes both o-ring part numbers 12057 and 07332 (item #3). Discard unused o-ring.

SPECIFICATIONS:	Defect	Cause	Remedy
Pressure Range: U.S. Metric (22971C): 580-1740 PSI .. (40-120 Bar) (22973C): 580-4060 PSI .. (40-280 Bar) (22974): 362-580 PSI (25-40 Bar) Maximum Flow: (22971C/22974): 35.7 GPM (135 LPM) (22973C): 26.4 GPM (99 LPM) Minimum Flow: 2.1 GPM (8 LPM) Maximum Temp.: .. 160 °F (70 °C) Inlet Port: 3/4" FNPT Outlet Port: 3/4" FNPT Bypass: 3/4" BSP	Valve switches repeatedly when gun is closed	Leaky Gun	Renew gun
		Leaky pressure pipe	Seal pressure pipe
		Leaky sleeve	Renew sleeve
		Worn out kick-back valve body (12A) or valve plate (14)	Renew kick-back valve body or plate. Examine valve seat.
	Leaky piston rod	Defective o-ring / support ring	Renew piston rod seals and examine surfaces in guide plug.
		Leaky bypass at nominal pressure	Nozzle too small, too much water
	Manometer shows high pressure peaks when shutting off gun		Worn out bypass valve
		Valve set too high above operating pressure	Turn back hexagon nut (17) or handwheel (22).
	Dirty Valve	Clean valve (lime deposits etc.). Grease parts before reinstalling	

Safety Instructions

IMPORTANT! Observe direction of flow. The bypass must under no circumstances be closed or fitting with any shut-off device.

IMPORTANT! Continuous bypass operation without releasing the water can cause the liquid to heat up which in turn could damage the unit and endanger persons.

Possible preventive measures:

1. Limit the bypass duration -maximum temperature 160 °F (60 °C); the duration is to be calculated by the operator and in conjunction with the operating conditions.
2. Use fittings (e.g. thermal relief valve on water inlet) to avoid heat increase.

Adjusting Pressure

1. Valve should be tension-free, i.e. loosen nut (17) or handwheel (22) so that the piston rod can be moved manually.
2. Spring set is to be tensioned by the nut (17) while pump is running with open gun (in case of more guns, all have to be open) until required operating pressure is reached and no more water runs out on bypass side.

If the nozzle holes is suited to the exact flow rate and pump pressure, water should not run via the bypass when required operating pressure is reached. If the nozzle hole is too small to allow all the fluid to run through the hole after the required operating pressure has been reached, on no account is the valve to be adjusted higher than the maximum operating pressure of the pump. In this case, the bypass is to be left partially open. It is therefore advisable to have suitable nozzles installed. The spacer discs (21A, 21B) which are under the spacer sleeve (16) are there to keep the adjusted pressure within limits. These discs are not to be removed.

⚠ Service and Adjustment

Reserving and adjusting work is only to be carried out by skilled tradesmen.

Renewal of Piston Seals

Remove guide plug (2) out of vlvae body and piston body (8). Remove guide plug from the piston rod (5). Cut out worn seals. Carefully slide o-ring (6) and support ring (7) onto piston rod. Note order of installation. Clip sleeve support ring (10) and cup (9) onto piston body. Check valve body surfaces and guide plugs (dirt or damage wears out seals quickly). Fasten piston body onto piston rod with Loctite 270. Grease all parts lightly with Silicone before reinstalling.

To Check Valves

Kick-Black Valve: Remove plug (13) on the outlet side and check whether valve plate (14) and valve seat (12A) are worn out. Check o-ring (14C) for damage.

Inlet Valve: Remove plug (13) on the inlet side; check ball (11) and seat (12A) for damage. Valve seats can be screwed out with an inside allen head wrench.

IMPORTANT! If the seat (12A) is worn, the ball (11) must be carefully impressed against the sealing edges of the seat. Glue in new valve seats with Loctite 270. Allow to dry for 60 minutes before putting into operation.



Performance Under Pressure

© Copyright 2022 Giant Industries, Inc.

Giant Industries, Inc.
 900 N. Westwood Ave.
 Toledo, Ohio 43607
 PHONE (419) 531-4600
 FAX (419) 531-6836
 www.giantpumps.com



WARNING: This product might contain a chemical known to the State of California to cause cancer, and birth defects or other reproductive harm. For more information go to: www.P65Warnings.ca.gov