

Model 22739

Pulsator Valve FOR USE ON P313* & P314 Pumps

* Manufactured from 8/00

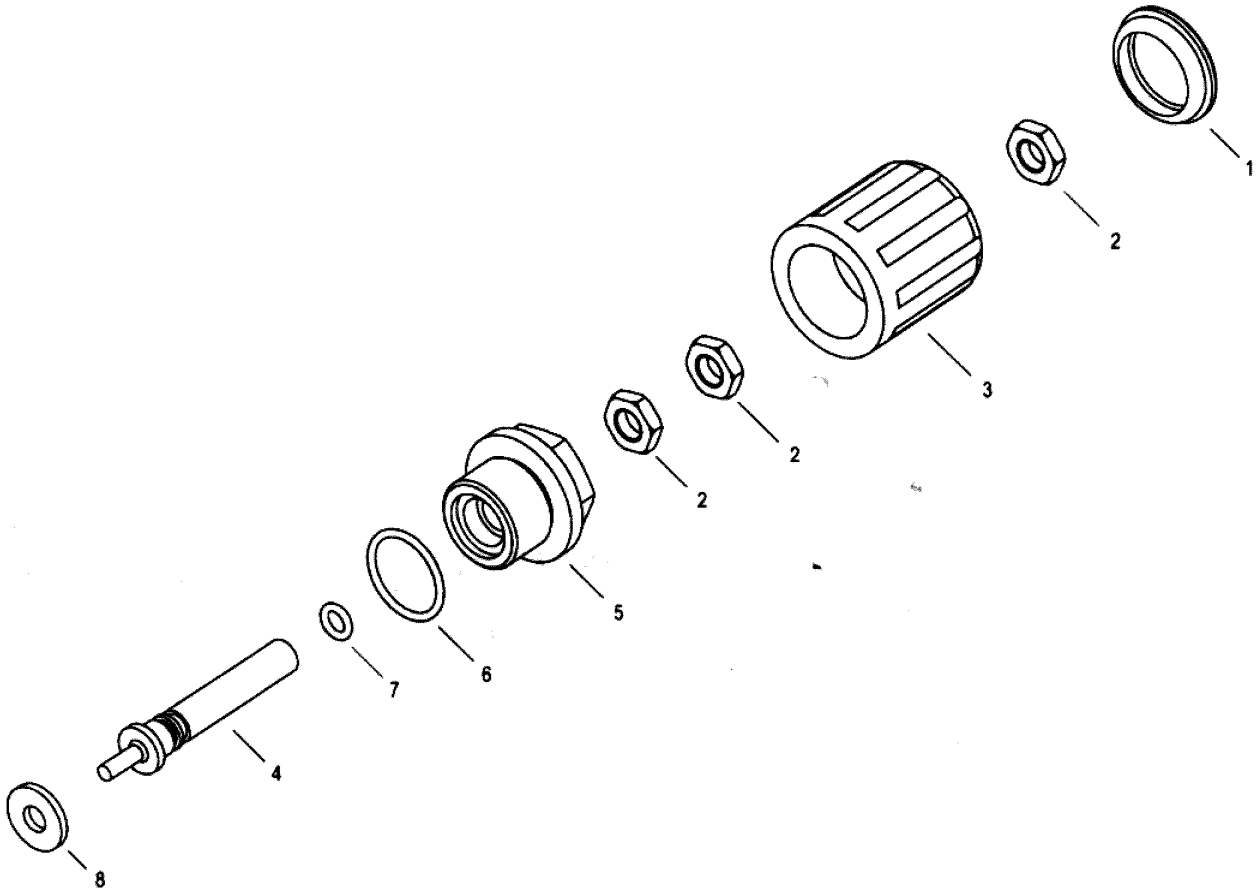

<u>Item</u>	<u>Part #</u>	<u>Description</u>	<u>Quantity</u>
1	07046	Cover	1
2	07044	Lock Nut	3
3	07045	Handwheel	1
4	06407	Adjusting Screw	1
5	06705	Valve Plug	1
6	07913	O-Ring	1
7	07937	O-Ring	1
8	06406	Spacer	1

GIANT

Giant Industries, Inc.
900 N. Westwood Ave.
P.O. Box 3187
Toledo, Ohio 43607
(419) 531-4600
FAX (419) 531-6836
www.giantpumps.com

© Copyright 2001 Giant Industries, Inc.

INSTALLATION INSTRUCTIONS

22739 Pulsator Valve

For use on P313* & P314 pumps

- 1). Remove center inlet valve plug from the front of the pump manifold.
- 2). Adjust the hand wheel (3) on the pulsator until it is all the way out by turning it counter clockwise. (Note: the handwheel will stop when it is all the way out.)
- 3). Install the pulsator assembly into the center inlet valve port and tighten with a 24 mm wrench.

OPERATING INSTRUCTIONS

- 1). To use the pump as a pulsating pump, turn the handwheel (3) clockwise until it is tight.
- 2). To use the pump as a pressure washer, turn the hand wheel counterclockwise until it stops.

** Manufactured from 8/00*