

K 9000A Triplex Plunger Pumps

Shown With High Pressure Head (A)

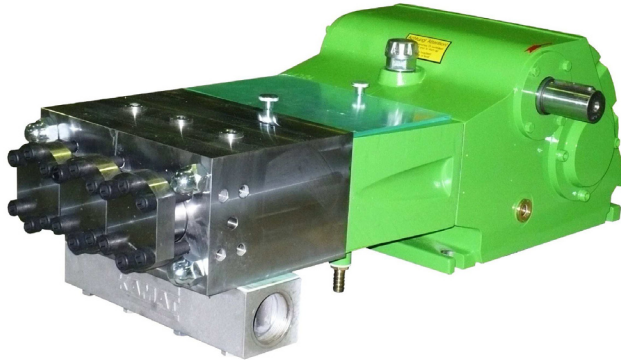

Rated Speed 530 RPM			Pressure at specific power inputs								Pump Head Style		
Type	FLOW		61 Hp	45 kW	74 Hp	55 kW	100 Hp	75 kW	121 Hp	90 kW	A	M	MC
	GPM	L/min	PSI	Bar	PSI	Bar	PSI	Bar	PSI	Bar			
K 9012	3.4	13	25672	1770	31320	2160	42775	2950	44950	3100	X		
K 9014	4.8	18	18565	1280	23055	1590	31175	2150	33350	2300	X		
K 9016	6.3	24	14214	980	17690	1220	24070	1660	26100	1800	X		
K 9018	7.9	30	11600	800	13993	965	18850	1300	20228	1395	X		
K 9020	9.8	37	9573	660	11600	800	15443	1065	16385	1130	X		
K 9022	11.9	45	7905	545	9643	665	12905	890	13485	930	X		
K 9024	14.3	54	6672	460	8048	555	10948	755	11383	785	X		
K 9026	16.6	63	5657	390	6888	475	9353	645	9643	665	X		
K 9028	19.3	73	4859	335	5945	410	8048	555	8338	575	X		
K 9030	22.2	84	4060	280	5003	345	6815	470	7250	500	X	X	
K 9032	25.4	96	3353	245	4350	300	5945	410	6380	440	X	X	X
K 9036	32.0	121	2755	190	3408	235	4640	320	5003	345		X	X
K 9040	39.6	150	2248	155	2755	190	3698	255	4060	280		X	X
K 9045	50.2	190	1740	120	2175	150	2900	200	3190	220			X
K 9050	61.8	234	1450	100	1740	120	2393	165	2610	180			X
K 9055	74.8	283	1160	80	1450	100	1958	135	2175	150			X

Subject to change without notice

- ◆ Flow rate is based on 100% volumetric efficiency and 68° F (20° C) ambient temperature.
- ◆ Depending on fluid medium, a minimum inlet pressure is required.
- ◆ Depending on rod loading, a minimum crankshaft RPM is required.
- ◆ Gear with force-fed lubrication (at 100 Hp/75kW, oil cooler required).
- ◆ Standard Gear Ratios: $i = 2.75, 3.22$ and 3.68
- ◆ Weight: 562 lbs (255 kg)
- ◆ API 674 specifications available upon request.
- ◆ Contact your local distributor or Giant Industries for use with special mediums. i.e. seawater, glycol, methanol, oil, etc.

Pump Dimensions mm(in)

High Pressure Head A

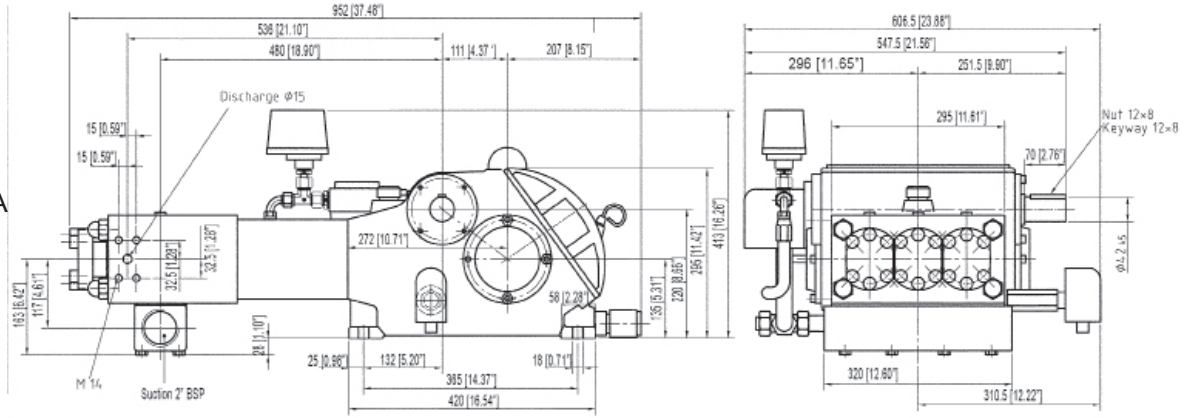

Compact Head M

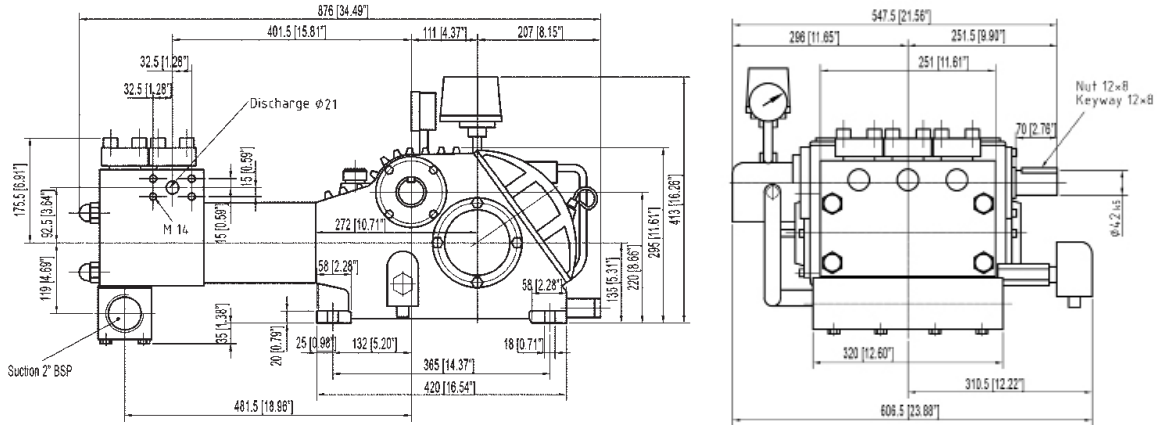

Compact Head (Low Pressure) MC

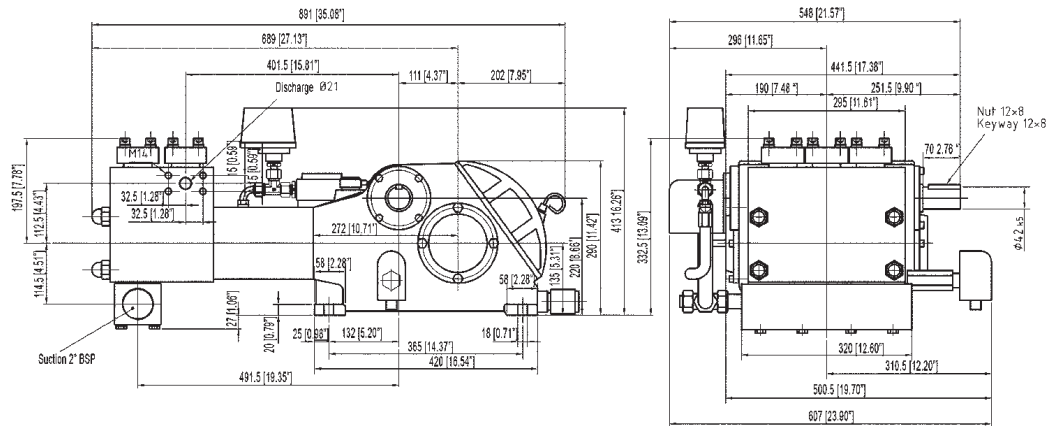

GIANT

Performance Under Pressure

GIANT INDUSTRIES, INC.

900 N. Westwood Ave.

Toledo, Ohio 43607

Phone: (419) 531-4600

Fax: (419) 531-6836

www.giantpumps.com

© Copyright 2014 Giant Industries, Inc.

High Pressure Head A
29,000 PSI (2000 Bar)

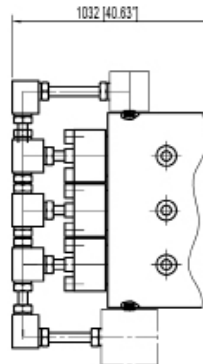

Footprint

