

## K 40000 - 3G Triplex Plunger Pump

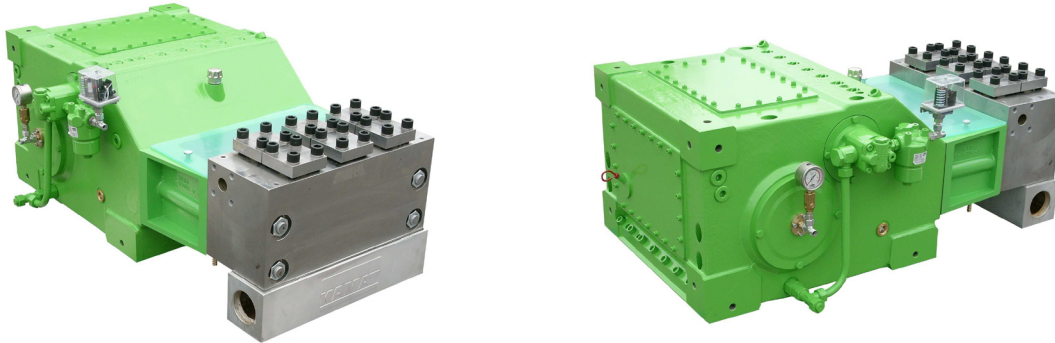

Rated Speed 440 RPM			Pressure at specific power inputs								Pump Head Style		
Type	FLOW		422 Hp	315 kW	442 Hp	330 kW	469 Hp	350 kW	536 Hp	400 kW	A	M	MC
	GPM	L/min	PSI	Bar	PSI	Bar	PSI	Bar	PSI	Bar			
K 40020 - 3G	15.3	58	33060	2280	41615	2870	46980	3240	50750	3500	X		
K 40022 - 3G	18.5	70	29725	2050	34510	2380	38860	2680	43500	3000	X		
K 40024 - 3G	21.9	83	28420	1960	29000	2000	31900	2200	36250	2500	X		
K 40026 - 3G	25.9	98	24215	1670	25375	1750	27550	1900	29000	2000	X		
K 40028 - 3G	30.1	114	20880	1440	21895	1510	23490	1620	26390	1820	X		
K 40030 - 3G	34.6	131	18850	1300	19575	1350	20880	1440	21750	1500	X		
K 40032 - 3G	39.4	149	16675	1150	17400	1200	18343	1265	20300	1400	X		
K 40036 - 3G	49.7	188	13123	905	13775	950	1450	1000	15950	1100	X		
K 40040 - 3G	61.3	232	10948	755	11310	780	11745	810	13050	900	X		
K 40045 - 3G	77.7	294	8628	595	9063	625	9280	640	10223	705	X		
K 40050 - 3G	95.9	363	6598	455	6960	480	7323	505	8120	560	X		
K 40055 - 3G	116.0	439	5438	375	5728	395	6090	420	6743	465		X	
K 40060 - 3G	138.2	523	4568	315	4785	330	5075	350	5655	390		X	X
K 40065 - 3G	162.0	613	3915	270	4133	285	4350	300	4785	330		X	X
K 40070 - 3G	187.8	711	3335	230	3553	245	3770	260	4133	285		X	X
K 40075 - 3G	215.6	816	2900	200	3045	210	3263	225	3625	250			X
K 40085 - 3G	277.1	1049	2320	160	2393	165	2538	175	2828	195			X
K 40095 - 3G	346.1	1310	1740	125	1885	130	2030	140	2248	155			X

Subject to change without notice

- ◆ Flow rate is based on 100% volumetric efficiency and 68° F(20° C) ambient temperature.
- ◆ Depending on fluid medium, a minimum inlet pressure is required.
- ◆ Depending on rod loading, a minimum crankshaft RPM is required.
- ◆ Dynamically balanced
- ◆ Gear with forece-fed lubrication and oil cooler
- ◆ Standard Gear Ratios: i = 3.39, 4.05, 4.76 and 5.25
- ◆ Weight: 2997 lbs (1360 kg)
- ◆ API 674 specifications available upon request.
- ◆ Contact your local distributor or Giant Industries for use with special mediums. i.e. seawater, glycol, methanol, oils, etc.

# Pump Dimensions mm(in)

## High Pressure Head A

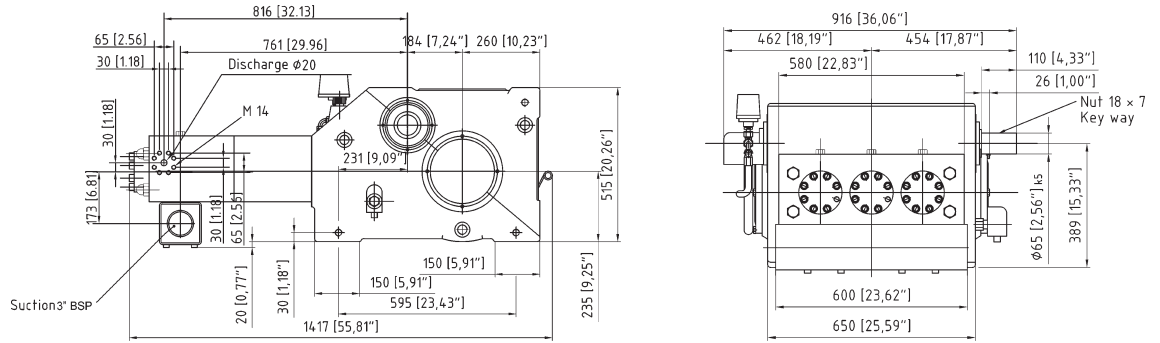

## High Pressure Head 29,000 PSI (2000 Bar) and above

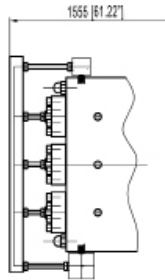

## Compact Head M

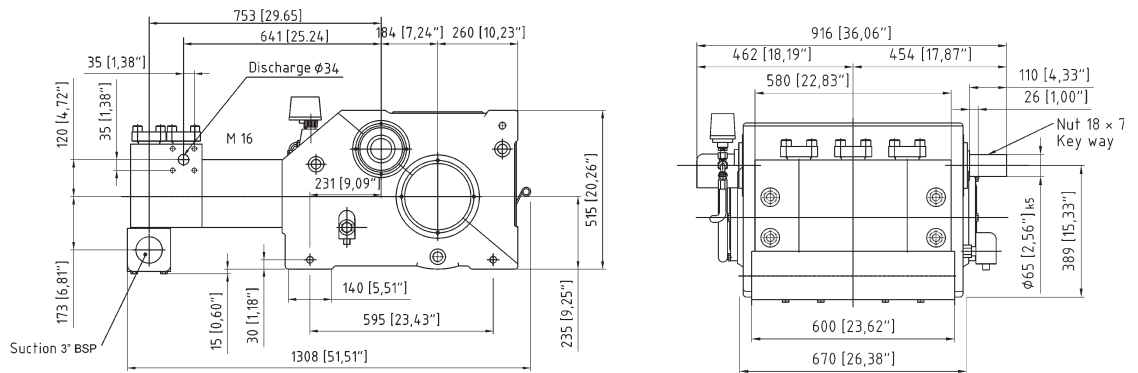

## Compact Head MC

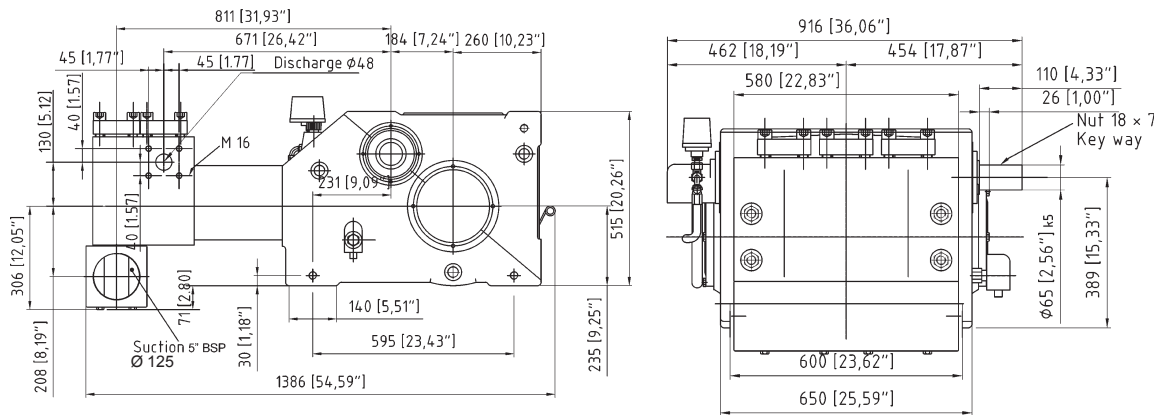

**GIANT**

Performance Under Pressure

GIANT INDUSTRIES, INC.

900 N. Westwood Ave.

Toledo, Ohio 43607

Phone: (419) 531-4600

Fax: (419) 531-6836

www.giantpumps.com

© Copyright 2013 Giant Industries, Inc.

### Footprint

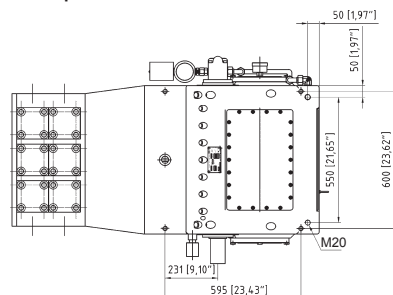

### Vertical Mount

