

# GP7550GBHS Series

Gearbox Versions for Hydraulic Drive Applications

---

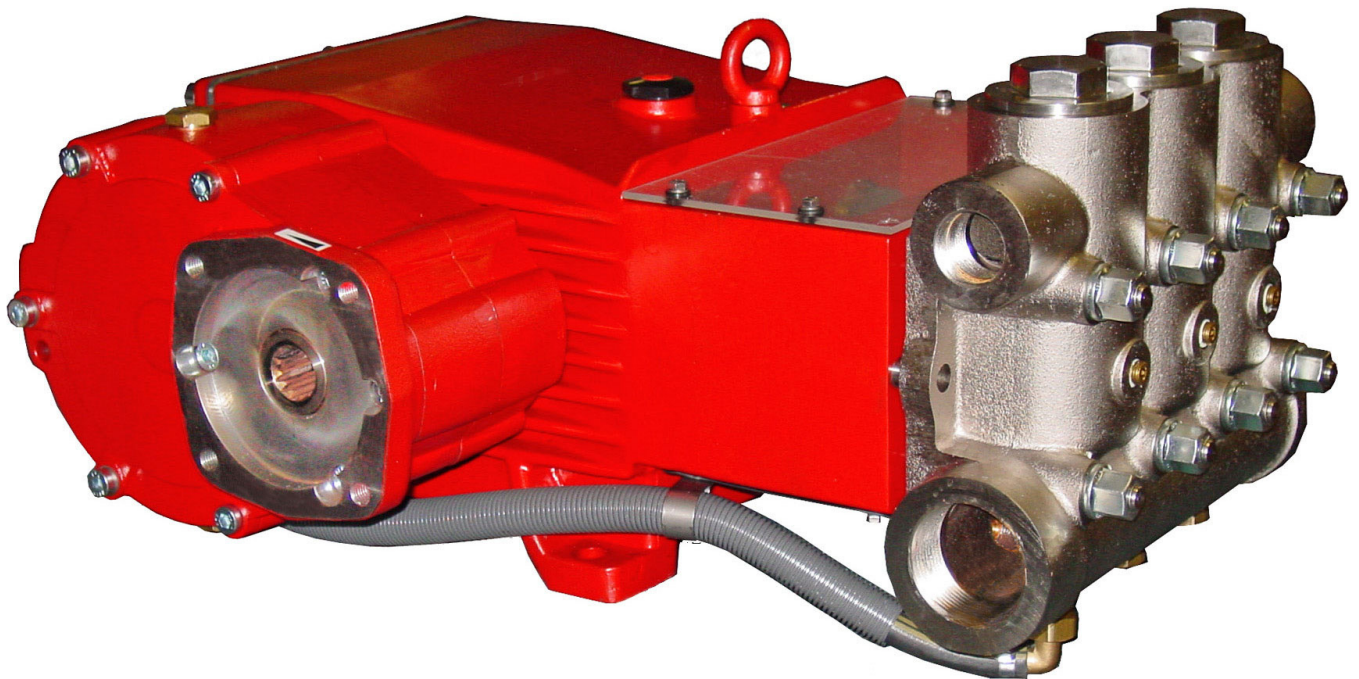

Updated 06/14

**Contents:**

Installation Instructions:	page 2
Pump Specifications:	page 3
Exploded View:	page 4
Parts List:	page 5
Kits:	page 6
Torque Specifications:	page 6
Maintenance Information:	page 6
Repair Instructions:	page 7
Dimensions:	back page
Warranty Information:	back page

# INSTALLATION INSTRUCTIONS

**Installation of the Giant Industries, Inc., pump is not a complicated procedure, but there are some basic steps common to all pumps. The following information is to be considered as a general outline for installation. If you have unique requirements, please contact Giant Industries, Inc. or your local distributor for assistance.**

1. The pump should be installed flat on a base to a maximum of a 15 degree angle of inclination to ensure optimum lubrication.
2. The inlet to the pump should be sized for the flow rate of the pump with no unnecessary restrictions that can cause cavitation. Teflon tape should be used to seal all joints. If the water temperature exceeds maximum temperature ratings or if aggressive water (sea-water, demineralized water) or other liquids are to be pumped, the integrated gear oil cooling system must be decoupled and a separate cooling circuit set up.

The gear oil cooling system must be used for driving power of more than 50kW in continuous operation and is advisable for maximum performance in intermittent operation of more than 60 minutes. The flow in the integrated gear oil cooling system is dependent on the plunger diameter and the pump rpm, and the cooling water is drawn and conveyed by one plunger. The amount of cooling water conveyed ensures satisfactory oil cooling under observation of the recommended rpm limits. If a separate cooling circuit is fitted, the cooling capacity must be 1500 W.

3. A tube fitting on the side of the pumphead which allows the circulation of water between the valve casing and seal sleeves to take place. The tube fitting must always be mounted on the same side as the suction line.

4. The discharge plumbing from the pump should be properly sized to the flow rate to prevent line pressure loss to the work area. It is essential to provide a safety bypass valve between the pump and the work area to protect the pump from pressure spikes in the event of a blockage or the use of a shut-off gun.

5. Use of a dampener is necessary to minimize pulsation at drive elements, plumbing, connections, and other system areas. The use of a dampener with Giant Industries, Inc. pumps is optional, although recommended by Giant Industries, Inc. to further reduce system pulsation. Dampeners can also reduce the severity of pressure spikes that occur in systems using a shut-off gun. A dampener must be positioned downstream from the unloader.

6. Crankshaft rotation on Giant Industries, Inc. pumps should be made in the direction designated by the arrows on the pump crankcase. Reverse rotation may be safely achieved by following a few guidelines available upon request from Giant Industries, Inc. Required horsepower for system operation can be obtained from the chart on page 3.

7. Before beginning operation of your pumping system, remember: Check that the crankcase and seal areas have been properly lubricated per recommended schedules. Do not run the pump dry for extended periods of time. Cavitation will result in severe damage. Always remember to check that all plumbing valves are open and that pumped media can flow freely to the inlet of the pump.

Finally, remember that high pressure operation in a pump system has many advantages. But, if it is used carelessly and without regard to its potential hazard, it can cause serious injury.

## **IMPORTANT OPERATING CONDITIONS** **Failure to comply with any of these conditions invalidates the warranty**

1. Prior to initial operation, add oil to crankcase so that the oil level is between the two lines on the oil dipstick. **DO NOT OVERFILL. SAE 80W-90 Industrial Gear Lube Oil may be used (Giant's p/n 01154).** Crankcase oil should be changed after the first 50 hours of operation, then at regular intervals of 500 hours or less depending on operating conditions.
2. Pump operation must not exceed rated pressure, volume, or RPM. The suction side input pressure must not exceed 29 PSI (2 bar) if the integrated gear oil cooling system is connected. The maximum system pressure for a separately fitted oil cooling system must likewise not exceed 29 PSI (2 bar).  
If the integrated gear oil cooling system is not used, the maximum admissible input pressure on the

pump suction side is 10 bar. In this case, transmitted pulsation from the pump to the suction line must be sufficiently damped. A pressure relief device must be installed in the discharge of the system.

3. Acids, alkalines, or abrasive fluids cannot be pumped unless approval in writing is obtained before operation from Giant Industries, Inc.
4. If there is danger of frost, the pump and adjoining components such as the unloader and safety valve as well as the cooling system must be emptied. Empty the pump through the second unused suction and discharge connection. Run the pump "dry" for 1-2 minutes to aid emptying.  
Empty the cooling system by removing screw joints K11 on the pump head and by blowing the hoses with compressed air on the K11/K7 side. Anti-freeze is recommended to guard against frost where a separate cooling circuit is used.

## GP7550GBHS SERIES

	U.S.	Metric
Volume.....	70 GPM	265 L/min
Discharge Pressure .....	2500 PSI	175 Bar
Speed .....		900 RPM
Inlet Pressure .....	145 PSI	10 Bar
Plunger Diameter.....	1.97"	50mm
Plunger Stroke.....	2.05"	52mm
Crankshaft Bore.....	SAE-C Spline 14T 12/24DP	
Key Width .....	14mm	
Crankshaft Mounting .....	Either side	
Shaft Rotation.....	Hydraulic Gear towards back of the pump	
Temperature of Pumped Fluids .....	104° F	40°C
Inlet Ports .....	(2) 2-1/2" NPT	
Discharge Ports.....	(2) 1-1/4" NPT	
Weight .....	474 lbs.	215 kg
Crankcase Oil Capacity.....	2.1 Gal.	8 Liters
Fluid End Material.....	Nickel-Plated Sheroidal Cast Iron	

**For the Application of a Hydraulic Motor:**

To Determine the Torque of a Hydraulic Motor --  $(\text{GPM} \times \text{PSI} \times 36.77) / \text{RPM} = \text{Torque (in-lbs)}$

<b>GP7550GBHS Series</b>		
<b>Gear Ratios and Input Speeds</b>		
<b>Pump Model*</b>	<b>Gear Ratio</b>	<b>Input Speed</b>
GP7550GBHS-1.67	1.67:1	1500
GP7550GBHS-2.0	2.0:1	1800
GP7550GBHS-2.4	2.44:1	2200

\*Different gearbox orientations are available; please consult factory

# EXPLODED VIEW - GP7550GBHS SERIES

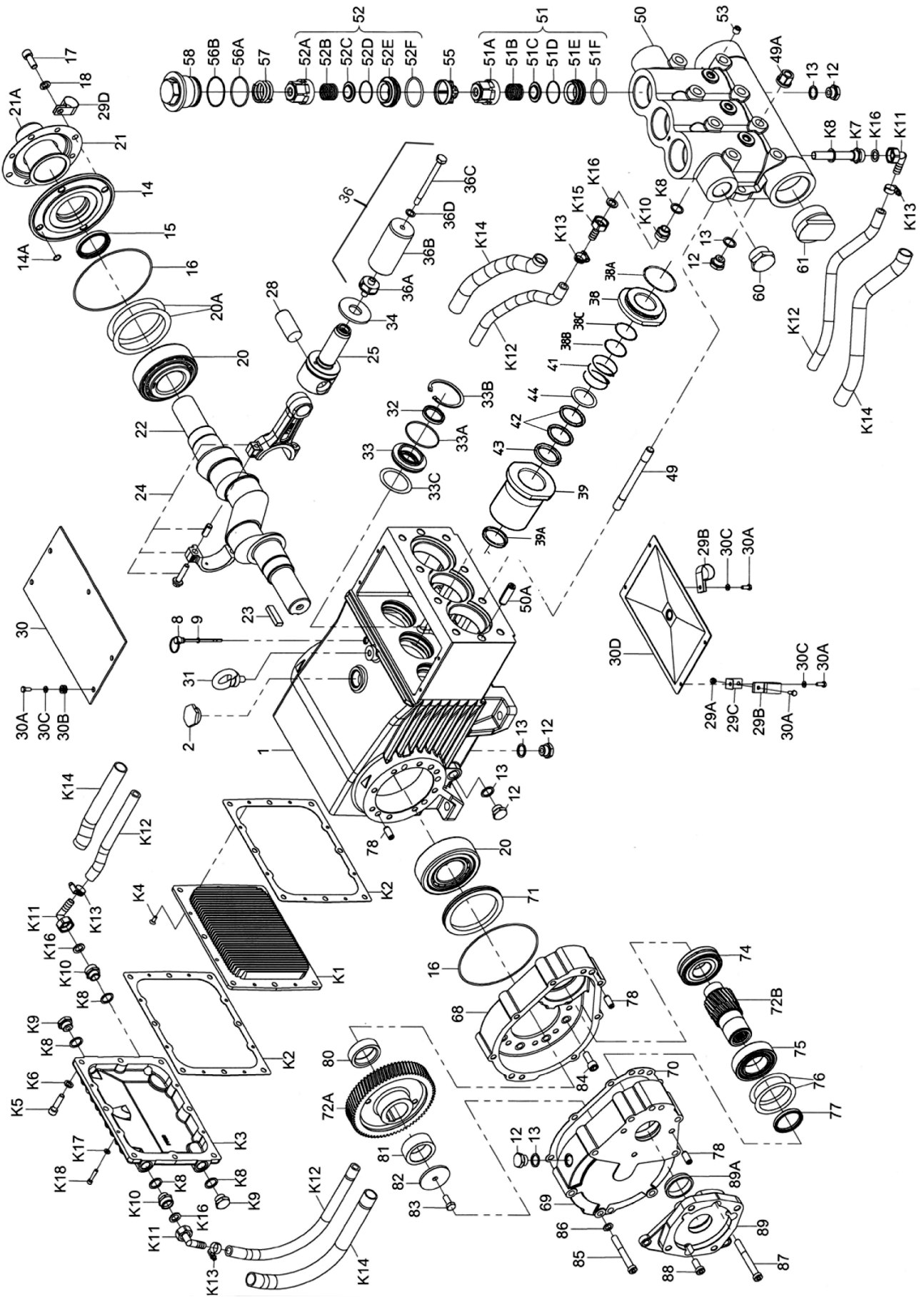



## GP7550GBHS SERIES PARTS LIST

<u>ITEM</u>	<u>PART</u>	<u>DESCRIPTION</u>	<u>QTY.</u>	<u>ITEM</u>	<u>PART</u>	<u>DESCRIPTION</u>	<u>QTY.</u>
1	05769	Crankcase	1				
2	13000	Oil Filler Plug Assembly	1	52	05600	Discharge Valve Assembly	3
8	07603	Oil Dip Stick	1	52A	05595	Spring Tension Cap	3
9	01009	O-Ring, Dip Stick	1	52B	05450	Valve Spring	3
12	07109	Drain Plug	9	52C	05247	Valve Plate	3
13	06272	Copper Seal for 12	9	52D	05596	O-Ring	3
14	05770	Bearing Cover	1	52E	05598	Discharge Valve Seat	3
14A	12204	O-Ring	4	52F	05599	O-Ring	3
15	05771	Radial Shaft Seal	1	53	22610	Plug, 1/4" NPT	3
16	05772	O-Ring	2	55	05647	Valve Spacer	3
17	05642	Hexagon Socket Screw	4	56A	07658	O-Ring	3
18	05039	Spring Washer	4	56B	07635	Support Ring	3
20	05773	Taper Roller Bearing	2	57	13173	Tension Spring	3
20A	05774	Fitting Disc (Shim)	1-5	58	06682	Plug, M64 x 2	3
21	05645	Shaft Guard Holder	1	60	12251	Pluge, 1-1/4" NPT	1
21A	05646	Shaft Guard	1	61	05170	Plug, 2-1/2" NPT	1
22	05775	Crankshaft	1	68	05782	Bottom Casing for Gear	1
23	05776	Key	1	69	05783	Top Casing for Gear	1
24	05777	Connecting Rod Assy.	3	70	05784	Gear Seal	1
25	05778	Crosshead Assy.	3	71	05785	Centering Ring	1
28	05779	Crosshead Pin	3	72A/B	05786	Gear Wheel Set, 1=2.44	1
29A	07408	Hexagon Nut	1	74	05787	Self-Aligning Roller Bearing	1
29B	05383	Bracket 2 f. Cooling Hose	2	75	05788	Cylinder Roller Bearing	1
29C	05662	Fixing Bracket	1	76	07117	Fitting Disc	5
29D	05381	Bracket 2 f. Cooling Hose	1	77	05789	Radial Shaft Ring	1
30	07619	Cover Plate	1	78	05665	Cylindrical Pin	6
30A	07225-0100	Hexagon Screw	9	80	05790	Spacer Ring 1 for Gear	1
30B	13136	Grommet	4	81	05791	Spacer Ring 2 for Gear	1
30C	08280	Disc	8	82	05802	Fixing Plate for Gear	1
30D	13154	Cover	1	83	13358	Hexagon Screw	1
31	07623	Eye Bolt	1	84	05792	Hexagon Socket Screw	7
32	07624	Radial Shaft Seal	3	85	05702	Hexagon Socket Screw	3
33	07626	Seal Retainer	3	86	07159	Washer	3
33A	07627	O-Ring for Seal Retainer	3	87	05793	Hexagon Socket Screw	5
33B	07628	Circlip for 33	3	88	05655	Hexagon Socket Screw	1
33C	07249	Fitting Disc	3	89	05794	Gear Flange, Hollow Shaft	1
34	13137	Oil Scraper (Flinger)	3	89A	05795	Centering Ring, Hollow Shaft	1
36	07630	Plunger Pipe Assy. (36A-D)	3		07662	Valve Tool (not shown)	1
36A	07667	Plunger Connection	3	90	04157	Oil Cooler Assembly	1
36B	07793	Plunger Pipe	3	K1	05797	Cooling Vane Plate	1
36C	07664	Tensioning Screw	3	K2	05798	Seal for Gear Cover	2
36D	07665	Copper Ring	3	K3	05799	Gear Cover	1
38	07794	Seal Case	3	K4	05029	Hexagon Head	
38A	13156	O-Ring	3			Countersunk Screw	4
38B	06258	O-Ring for 38	3	K5	05800	Hexagon Socket Screw	8
38C	07635	Support Ring	3	K6	06725	Washer	8
39	07795	Seal Sleeve	3	K7	05755	Connection for Oil Cooler	1
39A	07796	Grooved Ring	3	K8	06272	Copper Seal	6
41	07636	O-Ring	3	K9	07109	Plug, 1/2" BSP	2
42	07638	V-Sleeve	6	K10	05031	Reducing Nipple	3
43	07639	Pressure Ring	3	K11	05032	U-Joint Connector with Nut	3
44	05318	Sleeve Support Ring	3	K12	05033	Tube for Cooler	2
49	13159	Stud Bolt	8	K13	05402	Hose Clamp	4
49A	13160	Hexagon Nut	8	K14	05403	Hose Guard	2
50	07791	Valve Casing	1	K15	05404	Hose Coupling Nut	1
50A	13162	Centering Stud	2	K16	05405	Flat Gasket	4
51	05594	Inlet Valve Assembly		K17	08280	Washer	4
51A	05595	Spring Tension Cap	3	K18	04158	Hexagon Socket Screw	4
51B	05450	Valve Spring	3				
51C	05247	Valve Plate	3				
51D	05596	O-Ring	3				
51E	05597	Inlet Valve Seat	3				
51F	05166	O-Ring (51A-51F)	3				

## REPAIR KITS - GP7550GBHS SERIES

### Plunger Packing Kit - #09526

Item	Part #	Description	Qty.
38A	13156	O-Ring	3
38B	06258	O-Ring	3
38C	07635	Support Ring	3
39A	07796	Grooved Ring	3
42	07638	V-Sleeve	6

### Large Discharge Valve Kit - # 09660

Item	Part #	Description	Qty.
52	05600	Discharge Valve Assay	1
55	05647	Valve Spacer	1
56A	07658	O-Ring	1
56B	07635	Support Ring	1

### Oil Seal Kit - # 09221

Item	Part #	Description	Qty.
32	07624	Radial Shaft Seal	3
33A	07627	O-Ring	3

### Small Discharge Valve Kit \* # 09661

Item	Part #	Description	Qty.
51B	05450	Valve Spring	1
51C	05247	Valve Plate	1
51D	05596	O-Ring	1
52F	05599	O-Ring	1
56A	07658	O-Ring	1
56B	07635	Support Ring	1

### Inlet Valve Kit - # 09659

Item	Part #	Description	Qty.
51	05594	Inlet Valve Assembly	1
56A	07658	O-Ring	1
56B	07635	Support Ring	1

\* The discharge valve seat (item 52E) can be flipped over and used. If it is damaged on both sides, order kit # 09660.

## GP7550GBHS Torque Specifications

Position	Item#	Description	Torque Amount
24	05777	Connecting Rod Assembly	30 ft.-lbs. (40 NM)
36C	07664	Tension Screw	30ft.-lbs. (40 NM)
49A	13160	Hexagon Nut	103 ft.-lbs. (140 NM)
58	06682	Plug	107 ft-lbs (145 NM)

Preventative Maintenance Check-List & Recommended Spare Part List						
Check	Daily	Weekly	Every 50hrs	Every 500 hrs	Every 1500 hrs	Every 3000hrs
Oil Level / Quality	X					
Oil Leaks		X				
Water Leaks		X				
Belts, Pulley			X			
Plumbing			X			
Recommended Spare Parts						
Oil Change (p/n 01154)			X	X		
Plunger Packing Kits(1 kit/Pump)					X	
Oil Seal Kit (1 kit/Pump)					X	
Valve Kit (1 kit/pump)						X

# GB7550GBHS SERIES REPAIR INSTRUCTIONS

## TO CHECK VALVES

Loosen plugs (58), take out tension spring (57) and then remove the complete valve assembly (#51 & 52) with either a valve tool or an M16 hexagon screw. Check sealing surfaces and replace worn parts. The discharge valve seat (# 52E) can be used on both sides. If you re-use it, make sure you switch the O-Ring (#51D) to the opposite side. Check O-rings and support rings. Tighten plugs (58) to 107 ft.-lbs. (145 NM).

## TO CHECK SEALS AND PLUNGER PIPE

Loosen nuts (49A) and remove pump head (50). Separate the plunger connection (36A) from the crosshead (25) by means of an open-end wrench (size 36mm). Pull seal sleeves (39) out of their fittings in the crankcase (1). Take the seal case (38) out of the seal sleeve (39). Examine the plunger parts (36A-36D), seals (42 & 39A) and O-rings (38A & 38B). When replacing the plunger pipe (36B), tighten tension screws (36C) to 30 ft. lbs. (40 NM). Replace worn parts; grease seals with Silicone before installing.

**CAUTION:** Don't loosen the (3) plunger connections (36A) before the valve casing has been removed otherwise the tension screw (36C) could hit against the valve adapter (56) when the pump is being turned. Seal life can be increased if the pre-tensioning allows for a little leakage. This assists lubrication and keeps the seals cool. It is therefore not necessary to replace seals before the leakage becomes too heavy and causes output and operating pressure to drop.

## MOUNTING VALVE CASING

Check O-rings (38A & 38B) on the seal case (38). Clean surfaces of seal sleeves in gear box and sealing surfaces of valve casing (50). Push the valve casing carefully on the O-rings of the seal case and centering studs (50A). Tighten nuts (49A) to 103 ft. lbs. (140 NM).

## TO DISASSEMBLE GEAR

Take out plunger (36) and seal sleeves (39) as described above. Drain the oil. After removing the circlip ring (33B), lever out seal retainer (33) with a screw driver. Check seals (32 & 33A) and surfaces of crosshead (25). Remove the crankcase cover (4). Loosen inner hexagon screws on the connecting rods (24).

**Note:** Connecting rods are marked for identification. Do not twist connecting rod halves. Each connecting rod is to be reinstalled in the same position (and orientation) on the crankshaft journals.

Push the connecting rod halves as far into the crosshead guide as possible. Check the surfaces of connecting rod and crankshaft (22). Take out the bearing cover (14) to one side and push out crankshaft taking particular care that the connecting rod doesn't bend. Re-assemble in reverse order. Regulate axial bearing clearance to a minimum of 0.1mm and a maximum of 0.15mm by means of fitting discs (20A). The crankshaft should turn easily and with little clearance. Tighten screws (24) to 30 ft.-lbs. (40 NM).

**Important!** The connecting rod has to be able to slightly move sideways at the crankshaft journal.

**Important!** Seal (32) must always be installed so that the seal-lip on the inside diameter faces the oil. Possible axial float of the seal retainer (33) should be compensated with the shims (33C).

# GP7550GBHS SERIES DIMENSIONS - Inches (mm)

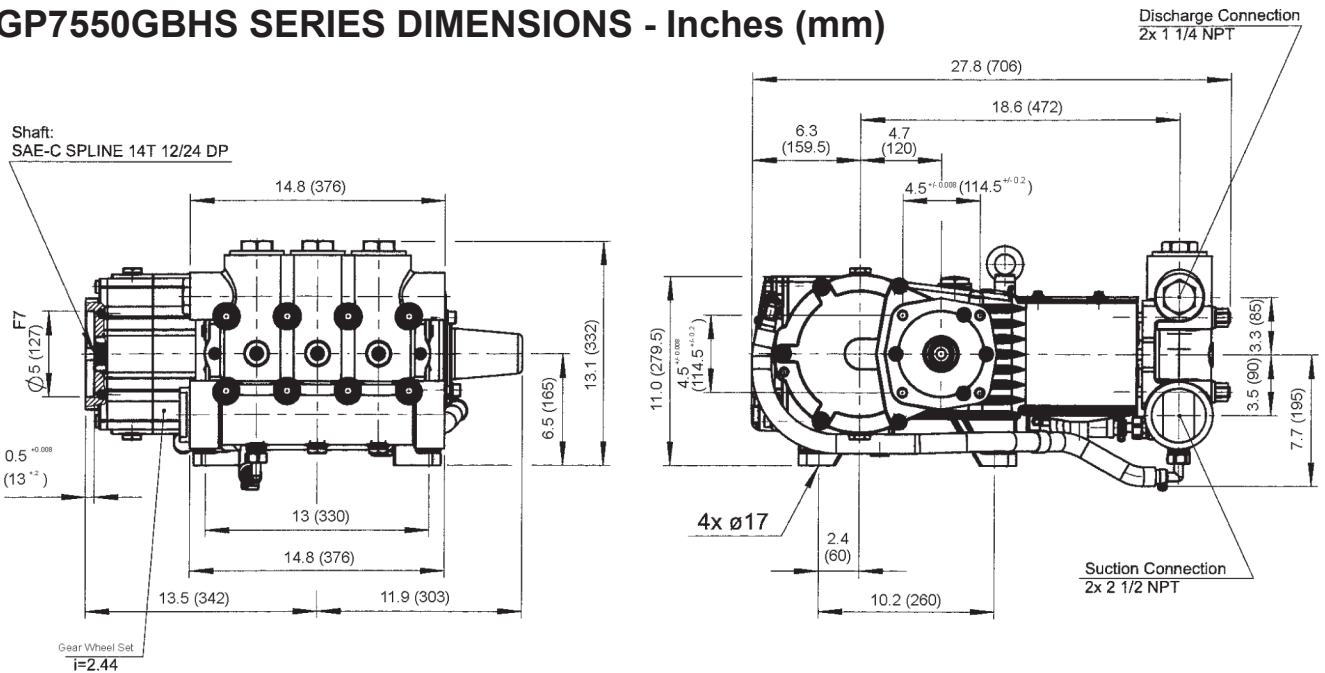

## GIANT INDUSTRIES LIMITED WARRANTY

Giant Industries, Inc. pumps and accessories are warranted by the manufacturer to be free from defects in workmanship and material as follows:

1. For portable pressure washers and self-service car wash applications, the discharge manifolds will never fail, period. If they ever fail, we will replace them free of charge. Our other pump parts, used in portable pressure washers and in car wash applications, are warranted for five years from the date of shipment for all pumps used in NON-SALINE, clean water applications.
2. One (1) year from the date of shipment for all other Giant industrial and consumer pumps.
3. Six (6) months from the date of shipment for all rebuilt pumps.
4. Ninety (90) days from the date of shipment for all Giant accessories.

This warranty is limited to repair or replacement of pumps and accessories of which the manufacturer's evaluation shows were defective at the time of shipment by the manufacturer. The following items are NOT covered or will void the warranty:

1. Defects caused by negligence or fault of the buyer or third party.
2. Normal wear and tear to standard wear parts.
3. Use of repair parts other than those manufactured or authorized by Giant.
4. Improper use of the product as a component part.
5. Changes or modifications made by the customer or third party.
6. The operation of pumps and or accessories exceeding the specifications set forth in the Operations Manuals provided by Giant Industries, Inc.

Liability under this warranty is on all non-wear parts and limited to the replacement or repair of those products returned freight prepaid to Giant Industries which are deemed to be defective due to workmanship or failure of material. A Returned Goods Authorization (R.G.A.) number and completed warranty evaluation form is required prior to the return to Giant Industries of all products under warranty consideration. Call (419)-531-4600 or fax (419)-531-6836 to obtain an R.G.A. number.

Repair or replacement of defective products as provided is the sole and exclusive remedy provided hereunder and the MANUFACTURER SHALL NOT BE LIABLE FOR FURTHER LOSS, DAMAGES, OR EXPENSES, INCLUDING INCIDENTAL AND CONSEQUENTIAL DAMAGES DIRECTLY OR INDIRECTLY ARISING FROM THE SALE OR USE OF THIS PRODUCT.

THE LIMITED WARRANTY SET FORTH HEREIN IS IN LIEU OF ALL OTHER WARRANTIES OR REPRESENTATION, EXPRESS OR IMPLIED, INCLUDING WITHOUT LIMITATION ANY WARRANTIES OR MERCHANTABILITY OR FITNESS FOR A PARTICULAR PURPOSE AND ALL SUCH WARRANTIES ARE HEREBY DISCLAIMED AND EXCLUDED BY THE MANUFACTURER.