

Models

Triplex Ceramic
Operating Instructions/
Manual

P56HT, P56HTK and P56W-HK

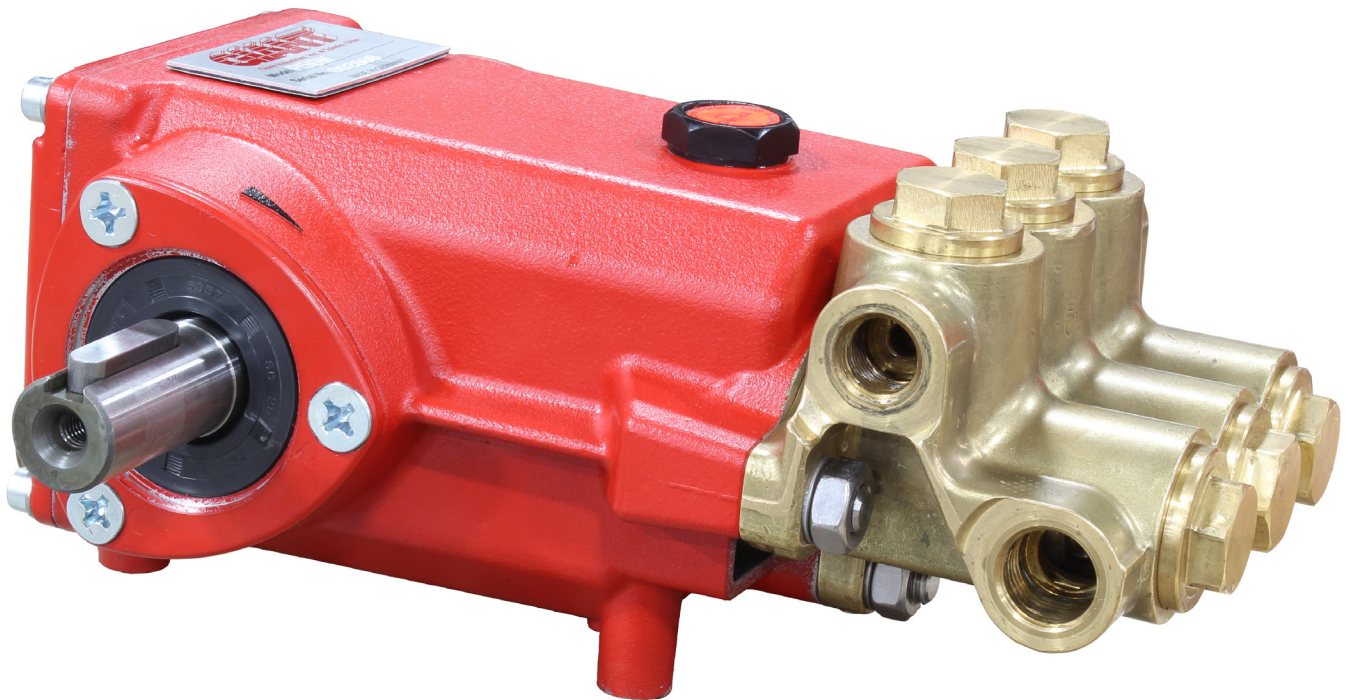

GIANT
Performance Under Pressure

Updated 02/22

Contents:

Installation Instructions:	page 2
Pump Specifications:	page 3
Exploded View:	page 4
Parts List:	page 5
Kits:	page 5
Repair Instructions:	pages 6-9
Pump Mounting Selection Guide:	page 10
Recommended Spare Parts List:	page 10
Torque Specifications:	page 10
Dimensions:	page 11
Warranty Information:	back page

Installation Instructions

Required NPSH refers to water: Specific weight 1 kg/dm³, viscosity 1°E at maximum permissible revolutions:

Operation and Maintenance

Check oil level prior to starting and ensure trouble-free water supply. Oil: Use only 12.5 ounces (0.37 litres) of Giant Oil (p/n 01154) or ISO VG 220 GL4 (e.g. Aral Degol BG220) or SAE 90 GL4 gear oil.

Initial change after 50 operating hours and then every 500 operating hours. In either case change oil every 6 months operation.

Caution! When operating in damp places or with high temperature fluctuations.

Oil must be changed immediately, should condensate (frothy oil) occur in the gear box.

Keep NPSH under control.

Max. input pressure 145 PSI (10 bar), maximum suction head -4.35 (-0.3 bar).



Safety Rules

Pump operation without safety valve as well as any excess in temperature or speed limits automatically voids the warranty. The safety valve must be regulated in accordance with the guidelines for liquid spraying units so that the admissible operating pressure can not be exceeded by more than 10%.

When the pump is in operation, the open shaft end must be covered up by shaft protector (17), the driven shaft side and coupling by a contact protector.

Pressure in discharge line and in pump must be at zero before any maintenance to the pump takes place. Close up suction line. Disconnect fuses to ensure that the driving motor does not get switched on accidentally.

Make sure that all parts on the pressure side of the unit are vented and refilled, with pressure at zero, before starting the pump.

In order to prevent air, or an air/water-mixture being absorbed and to prevent cavitation occurring, the pump-NPSHR, positive suction head and water temperature must be kept under control.

Cavitation and/or compression of gases lead to uncontrollable pressure-kicks which can ruin pump and unit parts and also be dangerous to the operator or anyone standing nearby.

Giant Plunger Pumps are suitable for pumping clean water and other non-aggressive or abrasive media with a specific weight similar to water.

Before pumping other liquids - especially inflammable, explosive and toxic media - the pump manufacturer must under all circumstances be consulted with regard to the resistance of the pump material. It is the responsibility of the equipment manufacture and/or operator to ensure that all pertinent safety regulations are adhered to.



Please read operating instructions carefully before putting the pump in operation!

Important! Do not use grease when renewing the high pressure plunger seals (31/31A). Hot water causes grease to wash off the seal which in turn can jam valves! The new seals should only be oiled lightly before installation.

Plant Lay-Out

For perfect functioning of the pump, the following points must be adhered to.

a) Pressure in Suction Side

The stipulated NPSHR is the minimum required pressure above the vapor pressure of the medium and is never to fall short of this figure. Temperature and vapor pressure of the medium, the geodetical height of the location, the flow rate and loss of friction in the suction line, must all be taken into consideration. It may be necessary to install a booster pump (centrifugal pump) in the suction line.

b) Pulsation

Due to its construction, the plunger pump creates pulsation in the suction and discharge lines. Suction pulsation in particular must be dampened in order to prevent resonance in the suction line which in turn, causes cavitation. Therefore, the pump is never to be connected by a rigid pipe but rather by a flexible hose (not reinforced by steel), and if possible 1.5 to 2 times wider than the suction connection. If a booster pump is used, the hose is to be attached between the booster pump and the high pressure pump.

If several pumps are used, each pump must have its own suction line. If this can't be done, a suction air chamber or a suction flow stabilizer must be installed in front of each pump. The bladder in the stabilizer is to be pretensioned on location.

Depending on the lay-out of the plant, a pressure accumulator may be necessary on the discharge side. This pressure accumulator must be installed right behind the discharge outlet of the high pressure pump. We recommend the use of only one pressure accumulator in the discharge line in order to avoid irritation which could be caused by different pre-tension levels in the accumulators.

Gas-tension in both the suction flow stabilizer and in the pressure accumulator are to be checked regularly.

Maintenance

Important!! To lubricate the high pressure seals, the intermediate casing (48) is filled with high-temperature resistant grease at our works. This means the holes in the valve casing have to be closed with thread plugs (29A) - to be tightened with Loctite 572.

Supplement Operating Instructions

The supplement operating instructions have been revised to now include the line "cooling water must be descaled to avoid lime formation due to warming" under the heading "Important". In addition, the temperature rating of 50 to 86 °F (10 to 30 °C) has been changed to 68 to 104 °F (20 to 40 °C) to increase safety against fracturing of the ceramic plungers caused by temperature shock.

The plant manufacturer should know that freshwater from the mains is not to be used for the cooling circuit (or alternatively the non-return rinse cooling option). In this case, there is a danger of lime and other contents separating from the water due to the heat and being deposited behind the high pressure seals and in the rinsing chamber. Such deposits lead to reduced seal life.

Normally the pumps on these (steam) boiler units are fed with treated water (condensate). For example, some water can be taken from the condensate container, reduced to 68 to 104 °F (20 to 40 °C) by a cooler, before being fed into cooling connections on the pump. This cooling water can then be led back to the condensate container or into the pump suction line.

Specifications

Models P56HT, P56HTK and P56W-HK

Model	Flow	Pressure	Power Required	Speed	Temperature
P56HT	193 GPH	870 PSI	2.5 BHP	750 RPM	220 °F
P56HT	233 GPH	870 PSI	2.5 BHP	900 RPM	195 °F
P56HTK	6.1 GPM	1900 PSI	7.9 BHP	1420 RPM	195 °F
P56W-HK	6.1 GPM	1900 PSI	7.9 BHP	1420 RPM	195 °F

Model	Flow	Pressure	Power Required	Speed	Temperature
P56HT	732 L/hr	60 bar	1.9 kW	750 RPM	104 °C
P56HT	882 L/hr	60 bar	1.9 kW	900 RPM	90 °C
P56HTK	23.1 L/min	130 bar	5.9 kW	1420 RPM	90 °C
P56W-HK	23.1 L/min	130 bar	5.9 kW	1420 RPM	90 °C

Common Specifications

Plunger Diameter.....0.787”20 mm
 Stroke0.713”18.1 mm
 Crankcase Oil Capacity 12.5 fl.oz.....(0.37 L)
 Inlet Ports.....(2) 1/2” NPT
 Discharge Ports(2) 3/8” NPT
 Crankshaft Mounting.....Top of Pulley Towards Fluid End
 Weight..... 17.2 lbs.....(7.8 kg)
 Crankshaft Diameter.....24 mm
 NPSHR (900/750 RPM).....21.3/19.7 ft. of head6.5/6.0 meters of water

Consult the factory for special requirements that must be met if the pump is to operate beyond one or more of the limits specified above.

PULLEY INFORMATION

Pulley selection and pump speed are based on a 1725 RPM motor and “B” section belts. When selecting desired GPM, allow for a ±5% tolerance on pumps output due to variations in pulleys, belts and motors among manufacturers.

1. Select GPM required, then select appropriate motor and pump pulley from the same line.
2. The desired pressure is achieved by selecting the correct nozzle size that corresponds with the pump GPM.

HORSEPOWER INFORMATION

Horsepower ratings shown are the power requirements for the pump. Gas engine power outputs must be approximately twice the pump power requirements shown above. We recommend that a 1.15 service factor be specified when selecting an electric motor as the power source. To compute specific pump horsepower requirements, use the following formula:

$$\frac{\text{GPM} \times \text{PSI}}{1450} = \text{hp}$$

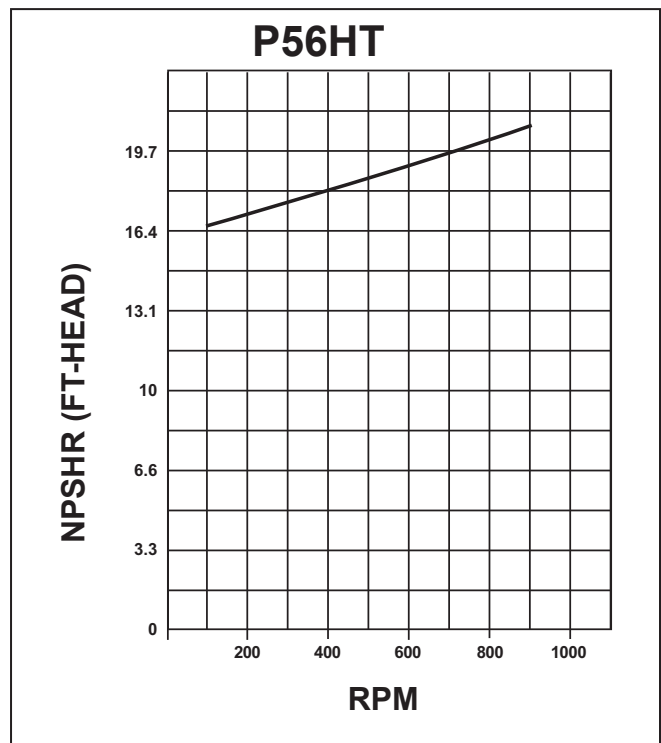

Exploded View - P56HT, P56HTK and P56W-HK

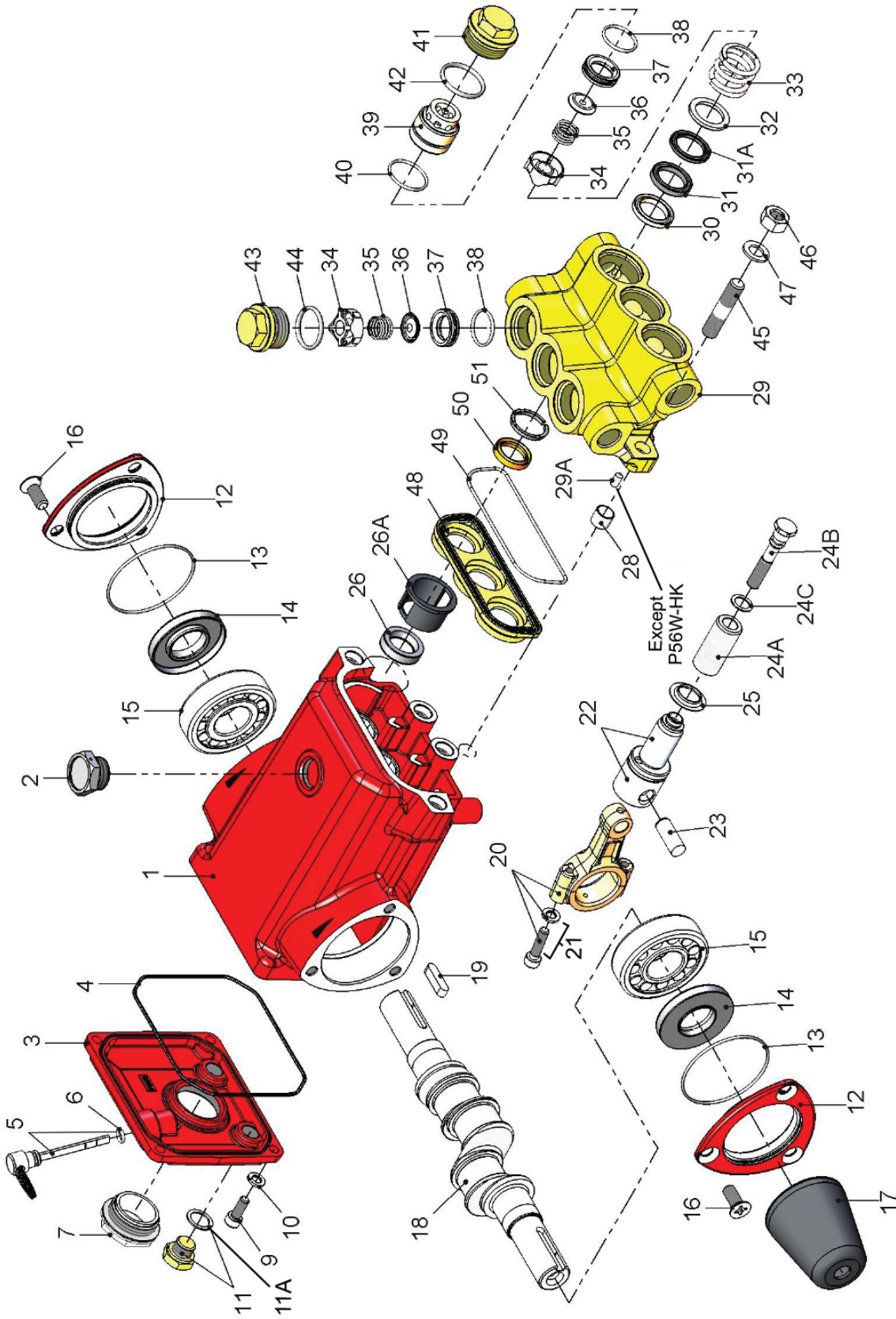

P56HT, P56HTK and P56W-HK Parts List

<u>ITEM</u>	<u>PART</u>	<u>DESCRIPTION</u>	<u>QTY.</u>	<u>ITEM</u>	<u>PART</u>	<u>DESCRIPTION</u>	<u>QTY.</u>
1	07180	Crankcase	1	28	07207	Shim, Manifold Stud	2
2	07181	Oil Filler Cap with Gasket	1	29	07369-NPT	Manifold Head	1
2A	07182	Gasket, Oil Filler Cap (not shown)	1	29A	11502	Set Screw (except P56W-HK)	2
3	07183	Cover, Crankcase	1	30	07221	Pressure Ring	3
4	07184	O-Ring, Crankcase Cover	1	31	13355	V-Sleeve (P56HT)*	3
5	07185	Oil Dip Stick Assembly	1	31	06076	Sleeve (P56HTK/HK)*	3
6	01009	O-Ring, Dip Stick	1	31A	06537	Sleeve**	3
7	07186	Oil Sight Glass Assembly	1	32	07209	Support Ring	3
8	07187	Gasket, Oil Sight Glass (not shown)	1	33	07210	Pressure Spring	3
9	07188	Screw, Crankcase Cover	4	34	05593	Retainer, Spring	6
10	07223-0100	Spring Washer	4	35	06017-0100	Valve Spring	6
11	07190	Oil Drain Plug Assembly	2	36	06016	Valve Plate	6
11A	13262	Gasket, Oil Drain Plug	2	37	06014	Valve Seat	6
12	07192	Bearing Cover	2	38	06015	O-Ring, Valve Seat	6
13	07193	O-Ring, Bearing Cover	2	39	13356	Adapter Inlet Valve	3
14	01166	Radial Shaft Seal	2	40	07212	O-Ring, Adapter	3
15	01086	Grooved Ball Bearing	2	41	07213	Plug, Manifold (Inlet)	3
16	07114	Screw, Bearing Cover	6	42	07214	O-Ring, Manifold Plug (Inlet)	3
17	05375	Shaft Protector	1	43	07792	Plug (Discharge)	3
18	13330	Crankshaft	1	44	07035	O-Ring, Manifold Plug (Discharge)	3
19	13331	Straight Key, 8mm	1	45	07215	Stud, Manifold	4
20	07199	Connecting Rod Assembly	3	46	08040	Hex Nut, Manifold Stud	4
21	01027	Conn. Rod Screw w/ Washer	6	47	08041	Spring Washer, Stud	4
22	07201	Plunger Base w/ S.S. Crosshead	3	48	07036	Housing, Rear V-Sleeve (P56HT/HK)	1
23	01031	Crosshead Pin	3	48	07036A	Housing, Rear V-Sleeve (P56HTK)	1
24A	06066	Ceramic Plunger	3	49	07218	O-Ring, Rear V-Sleeve Housing	1
24B	08456	Tension Screw	3	50	08358	Grooved Seal Ring, Black	3
24C	07676	Copper Gasket	3	51	06240	Support Ring	3
25	06648	Flinger	3				
26	07206	Crankcase Oil Seal	3				
26A	07764	Spacer Sleeve	3				

* Seal Height ≈ 5.3 mm
 ** Seal Height ≈ 3.6 mm

P56HT and P56HTK REPAIR KITS

Plunger Packing Kits

P56HT, #09457

<u>Item</u>	<u>Part #</u>	<u>Description</u>	<u>Qty.</u>
31	13355	V-Sleeve	3
31A	06537	High Temperature Seal	3
40	07212	O-Ring Adaptor	3
42	07214	O-Ring Manifold Plug (Inlet)	3
44	07035	O-Ring Manifold Plug (Discharge)	3
49	07218	O-Ring	1
50	08358	Grooved Seal Ring	3
51	06240	Support Ring	3

Valve Assembly Kit, #09458

<u>Item</u>	<u>Part #</u>	<u>Description</u>	<u>Qty.</u>
34	05593	Retainer, Valve Spring	6
35	06017-0100	Valve Spring, S.S.	6
36	06016	Valve Plate	6
37	06014	Valve Seat	6
38	06015	O-Ring	6

Oil Seal Kit, #09202

<u>Item</u>	<u>Part #</u>	<u>Description</u>	<u>Qty.</u>
26	07206	Crankcase Oil Seal	3

P56HTK and P56W-HK, #09815

<u>Item</u>	<u>Part #</u>	<u>Description</u>	<u>Qty.</u>
31	06076	V-Sleeve	3
31A	06537	High Temperature Seal	3
40	07212	O-Ring Adaptor	3
42	07214	O-Ring Manifold Plug (Inlet)	3
44	07035	O-Ring Manifold Plug (Discharge)	3
49	07218	O-Ring	1
50	08358	Grooved Seal Ring	3
51	06240	Support Ring	3

P56HT, P56HTK and P56W-HK REPAIR INSTRUCTIONS

NOTE: Always take time to lubricate all metal and nonmetal parts with a light film of oil before reassembly. This step will ensure proper fit, at the same time protecting the pump nonmetal parts (i.e., the elastomers) from cutting and scoring.

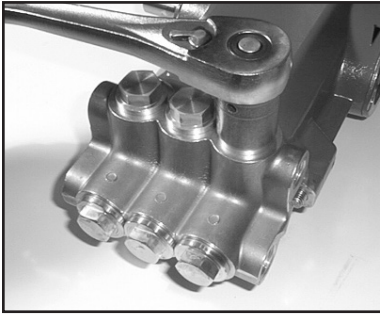

1. With a 22mm socket, remove the three discharge (43) and three inlet (41) manifold plugs. Check o-ring (44) for wear and replace as necessary.

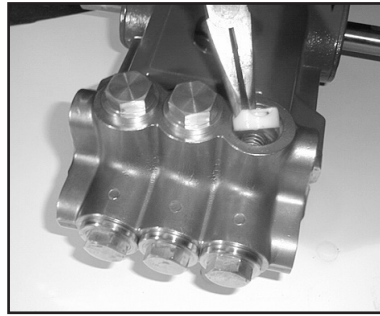

2. Remove the discharge spring retainer (34), valve spring (35), and valve plate (36).

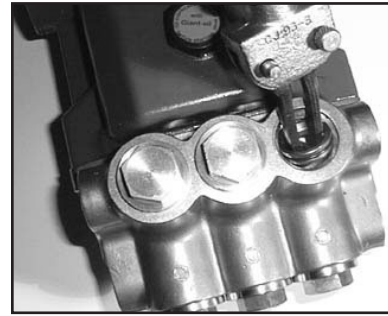

3. Use a small slide hammer to remove valve seats (37) from manifold (29). Inspect valve plates (36) and valve seats (37) for wear. If excessive pitting is seen, replace the worn parts. Check valve seat o-ring (38) for wear and replace as necessary. Tighten manifold plugs (41 and 43) to 52 ft.-lbs. (70 Nm).

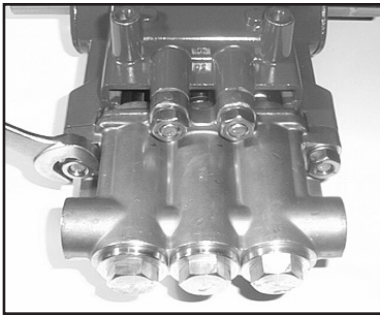

4. Drain the oil from the pump. Turn the pump over to remove the four manifold stud nuts (46) with a 17mm wrench.

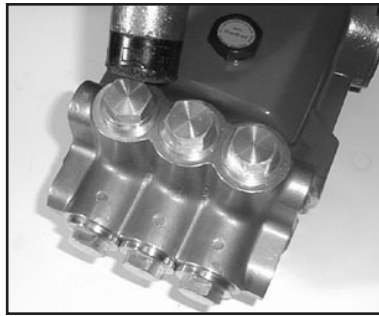

5. Tap the back of the manifold (29) with a rubber mallet to dislodge, and slide off the pump.

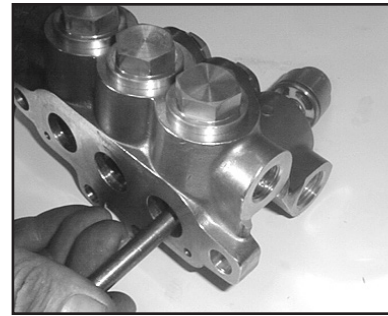

6. From the front inlet valve ports, remove the inlet valve assembly (34-40) and pressure springs (33).

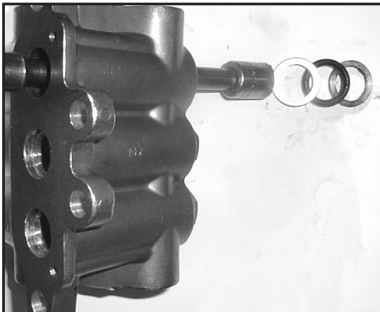

7. Turn the manifold (29) over. Using a 15mm socket, tap out the v-sleeves. Insert v-sleeve (31 & 31A), support rings (32), and pressure rings (30) through back of manifold.

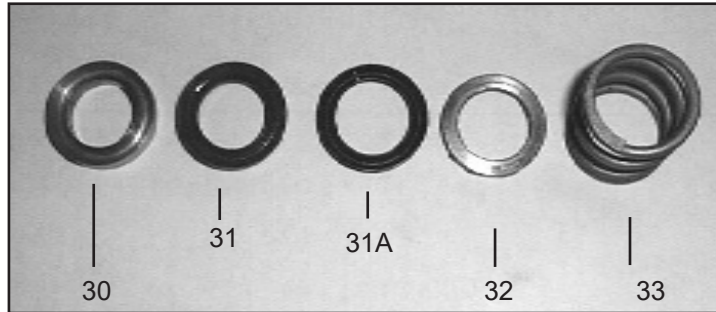

8. Inspect and clean the manifold and pressure ring. Reinstall the pressure ring (30) with the grooved side pointed towards the front. Insert v-sleeves (31/31A), support ring (32), and pressure spring (33) into the manifold (29).

P56HT, P56HTK and P56W-HK REPAIR INSTRUCTIONS

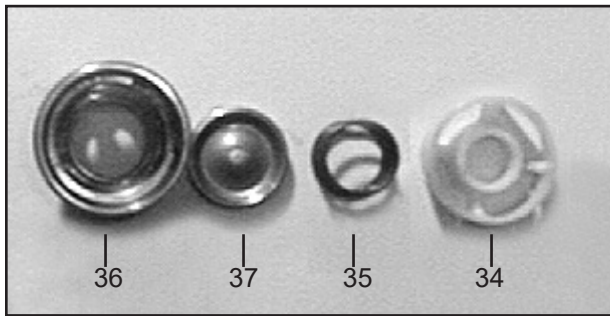

9. If pitted or worn, replace inlet valve seats (36), valve plates (37), springs (35) and spring retainers (34). Re-insert items 34-38 into valve adapter (39). Install valve assembly (34-40) into manifold (29). Reinstall manifold plugs (43) and torque plugs to 52 ft.-lbs. (70 Nm).

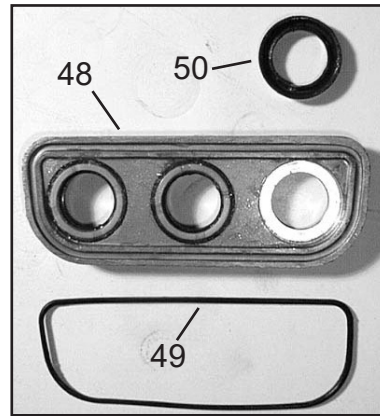

10. The rear v-sleeve housing (48) may be removed by prying evenly outward with a flat screwdriver. After slipping housing over ceramic plunger (24A), inspect seals (50) and o-ring (49) and replace as necessary. If the crankcase is to be disassembled, the housing should not be replaced until later.



11. Inspect ceramic plunger (24A) tips for wear. If necessary, replacement of the ceramic plungers may be accomplished by removing the plunger bolt assemblies (24B and 24C) with a 13mm wrench. Ceramic plungers should now slide off the stainless steel plunger base (22). Excessive resistance to plunger removal may be overcome by heating the stainless steel plunger base. This will melt any excess loc-tite beneath the ceramic plunger allowing easy removal.

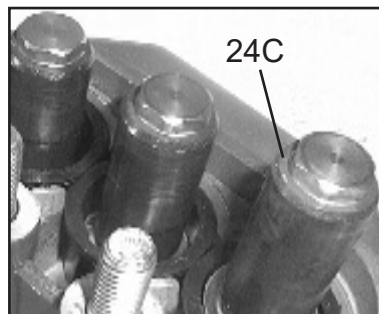

12. Replace copper ring (24C) onto plunger bolt (24B). Slide plunger bolt assembly into ceramic plunger (24A). Apply a light film of loc-tite to plunger bolt threads and place plunger assembly onto stainless steel plunger base (22) and tighten to 200 in.-lbs. (22.5 Nm).

13. To replace plunger oil seals (26), proceed to "Gear End Disassembly" section below. Otherwise, continue as described below.



14. Before replacing pump manifold (29), first rotate crankshaft (18) until two outside plungers (24A) extend evenly forward. Next lubricate v-sleeves (50) in the rear v-sleeve housing (48) and slide housing over plungers. Lubricate ceramic plungers with a light film of oil. Carefully and evenly slide manifold over plungers and press manifold firmly against crankcase (1). Replace manifold stud bolts (45), washers (47) and nut (46) and tighten to 35 ft.-lbs. (47.5 Nm).

P56HT, P56HTK and P56W-HK REPAIR INSTRUCTIONS

Gear End Disassembly

NOTE: The manifold (29) weep seal housing (48) and spacer sleeve (26A) must be removed. See above for directions.

15. Remove the crankcase cover screws (9). Inspect the crankcase cover o-ring (4) for wear. Replace if necessary.
16. Inspect the dipstick (5) vent hole for signs of clogging. Clean if necessary.
17. To remove the crankshaft (18), first remove the bearing cover plates (12). Remove the key (19).
18. With a 5 mm allen wrench remove the connecting rod screws (21) and rear portion of connecting rod assemblies (20). Push the connecting rod (20) and plunger rod (22) down as far as possible into the crankcase housing.
19. Hold the pump rear assembly with a wooden fixture, or other suitable device, in order to secure it while removing the crankshaft (18). Using a plastic mallet, tap the crankshaft from one side while turning it from the other side. The turning insures that during this sequence the crankshaft does not become wedged against the front portion of the connecting rods (20). The far side bearing (15) will remain in the crankcase (1). When free, the crankshaft can be removed by hand. The opposite side crankshaft seal (14) will be removed by this procedure. **It is important that you turn the crankshaft (18) constantly while tapping from the opposite end to avoid any binding. The crankshaft bearing (15) remains on the crankshaft as it is removed.** If necessary, use a bearing puller to remove the crankshaft bearing (15).
20. Remove the front portion of the connecting rods (20) and plunger base assembly (22) from the rear of the pump by pulling straight out of the crankcase crosshead guides. **Notice that the connecting rod (20) halves are numbered or colored. Connecting rods must be positioned with their numbers or colors on the upper left-hand side, in the same numerical sequence as when they were removed.**
21. Using a dowel and a rubber mallet, tap the oil seals (26) out from the rear of crankcase (1). The area onto which the oil seal rests should be clean and dry. Put a small drop of loc-tite on the oil seals and place into crankcase with lips facing the rear of the pump.
22. To remove the crosshead pin (23) from the crosshead (22), the assembly should be positioned on a wooden fixture to avoid damage to crosshead. Drive out the pin on opposite side of mark located on the crosshead. On those pumps without mark on crosshead, drive out pin by tapping on tapered side of pin.
23. To remove the bearing (15) remaining in the crankcase (1), insert small end of Giant bearing tool and tap with a rubber mallet until bearing and seal (14) are completely removed. **The bearing can only be removed from the inside by inserting the Giant Bearing Tool through the opposite side of the crankcase.** The crosshead guide in the crankcase should be inspected for possible damage.
24. To reassemble, place the far bearing (15) in the crankcase (1) bearing housing and with the Giant Bearing tool as a driver, tap into the crankcase using a rubber mallet.
25. Insert the far side crankshaft oil seal (14) with the Giant Bearing Tool making sure it is firmly seated and well oiled. Always make sure that the crankshaft seal lip does not show signs of wear and that the garter spring is firmly in place on the seal before reinserting into the pump. Replace the bearing cover (12) and o-ring (13) and tighten securely.

P56HT, P56HTK and P56W-HK REPAIR INSTRUCTIONS

26. Replace the front portion of the connecting rod (20) and plunger rod/ crosshead assembly (22) by press-fitting the crosshead pin (23). Make sure to insert the beveled edge of the crosshead pin into crosshead. If the crosshead has a mark, install pin from marked side. **The crosshead pin (23) should not extend beyond either side of the crosshead (22) in order to prevent damage to the crosshead bore of the crankcase (1).**
27. Place each crosshead/ plunger assembly into the pump making sure that all of the parts are well oiled before insertion into the crankcase (1). **Notice that the connecting rod (20) halves are numbered or colored. Connecting rods must be positioned with their numbers or colors on the upper left-hand side, in the same numerical sequence as when they were removed.**
28. Replace near side bearing (15) on crankshaft by using the Giant Bearing Tool and mallet to tap into place. Take the crankshaft (18) end with the bearing (15) and insert the other end through the bearing housing and tap with a rubber mallet until the bearing is seated.
29. When reassembling the connecting rods (20), note that the connecting rod halves are numbered or colored and that the numbers or colors must be matched and aligned. Torque the connecting rod bolts to 133 in.-lbs. (15 Nm).
30. Insert the near side crankshaft oil seal (14) with the Giant Bearing Tool making sure it is firmly seated and well oiled. Replace the bearing cover (12) and o-ring (13) and tighten securely.
See instructions above for re-installing fluid end onto the gear end.
31. Fill the pump crankcase (1) with 12.5 oz. (0.37 L) of Giant Industries' oil and check the oil level with the dipstick (5). Proper level is center of two lines. Reinstall the pump into your system.

Preventative Maintenance Check-List & Recommended Spare Parts List

Check	Daily	Weekly	50hrs	Every 500 hrs	Every 1500 hrs	Every 3000 hrs
Oil Level/Quality	X					
Oil Leaks	X					
Water Leaks	X					
Belts, Pulley		X				
Plumbing		X				
Recommended Spare Parts						
Oil Change (1 Gallon) p/n 1154			X	X		
Plunger Packing Kits (See page 5 for kit list) (1 kit/pump)					X	
Valve Assembly Kit (1 kit/pump) (See page 5 for kit list)					X	
Oil Seal Kit (1 kit/pump) (See page 5 for kit list)						X

Pump Mounting Selection Guide

<p>Bushings 01074 - 24 mm Tapered H Bushing</p>	<p>Rails 01034 - Steel Box Rails (L=9.25" x W=1.18" x H=1.62") 01075 - Plated Steel Channel Rails (L=9.00" x W=2.12" x H=2.50")</p>
<p>Pulley & Sheaves 01055 - 9.75" Cast Iron - 2 gr.-AB Section 01061 - 7.75" Cast Iron 1 gr. - AB Section 01062 - 7.75" Cast Iron - 2 gr. - AB Section</p>	

P56HT, P56HTK and P56W-HK TORQUE SPECIFICATIONS

Position	Item #	Description	Lubrication Info	Torque Amount
7	07186	Oil Sight Glass	Loctite 5910	106 in.-lbs. (12 Nm)
9	07188	Screw, Crankcase Cover		88 in.-lbs. (10 Nm)
11	07190	Oil Drain Plug Assembly		22 ft.-lbs. (30 Nm)
16	07114	Screw, Bearing Cover		133 in.-lbs. (15 Nm)
21	01027	Connecting Rod Screw		133 in.-lbs. (15 Nm)
24B	08456	Tension Screw	Loctite 243	200 in.-lbs. (22.5 Nm)
41	07213	Plug		52 ft.-lbs. (70 Nm)
43	07792	Plug	Loctite 243	52 ft.-lbs. (70 Nm)
46	08040	Nut		35 ft.-lbs. (47.5 Nm)

P56HT, P56HTK and P56W-HK DIMENSIONS - INCHES (mm)

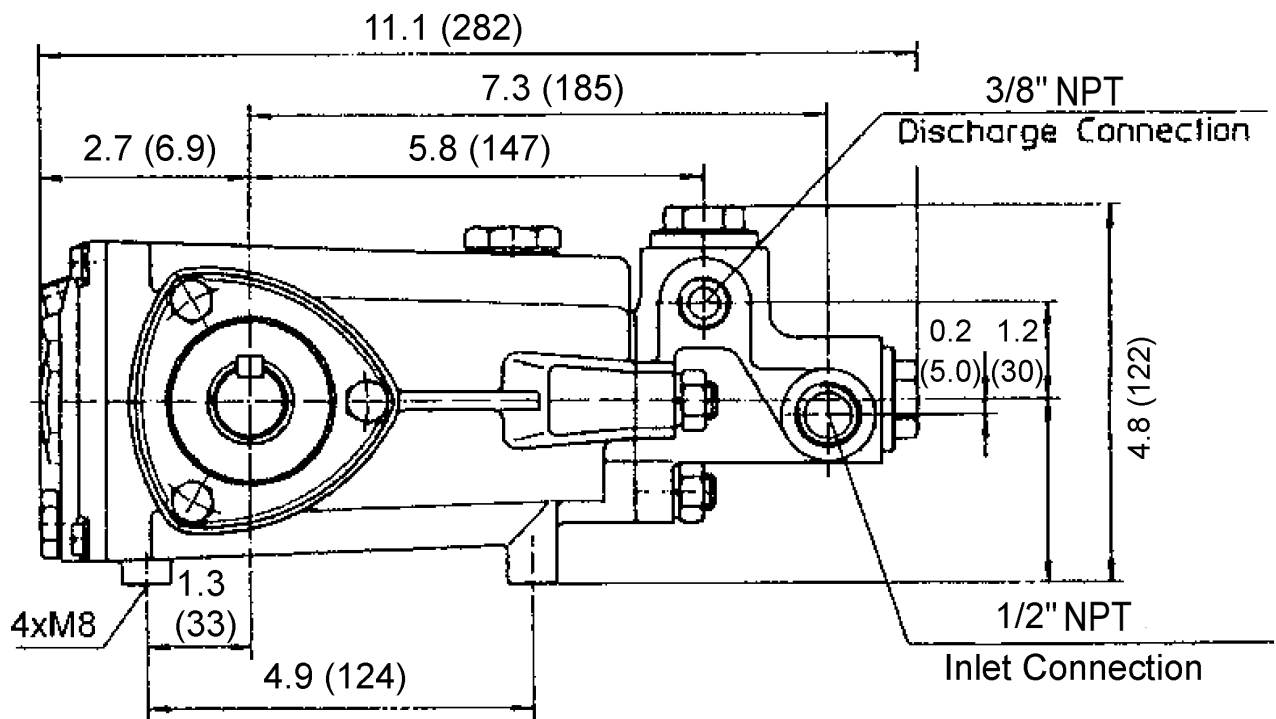
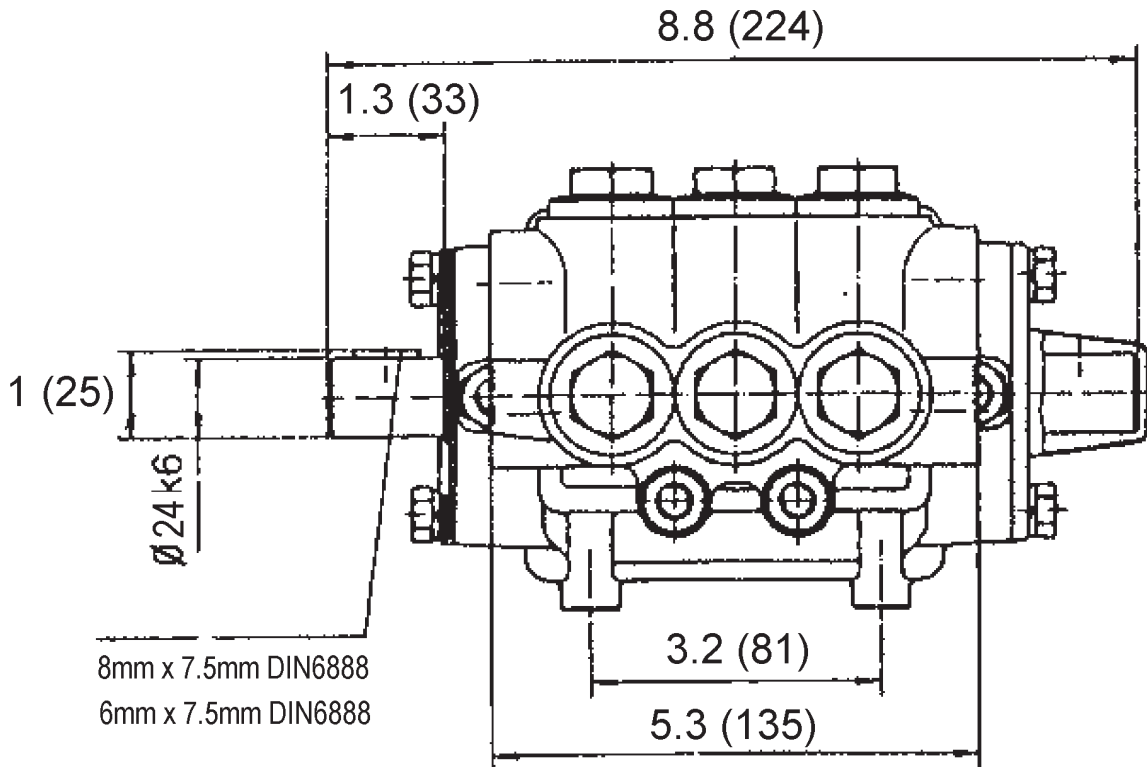

GIANT INDUSTRIES LIMITED WARRANTY

Giant Industries, Inc. pumps and accessories are warranted by the manufacturer to be free from defects in workmanship and material as follows:

1. Five (5) years from the date of shipment for all pumps used in portable pressure washers with NON-SALINE, clean water applications.
2. Two (2) years from the date of shipment for Giant pumps used in car wash applications.
3. One (1) year from the date of shipment for all other Giant industrial and consumer pumps.
4. Six (6) months from the date of shipment for all rebuilt pumps
5. Ninety (90) days from the date of shipment for all Giant accessories.

This warranty is limited to repair or replacement of pumps and accessories of which the manufacturer's evaluation shows were defective at the time of shipment by the manufacturer. The following items are NOT covered or will void the warranty:

1. Defects caused by negligence or fault of the buyer or third party.
2. Normal wear and tear to standard wear parts.
3. Use of repair parts other than those manufactured or authorized by Giant.
4. Improper use of the product as a component part.
5. Changes or modifications made by the customer or third party.
6. The operation of pumps and or accessories exceeding the specifications set forth in the Operations Manuals provided by Giant Industries, Inc.

Liability under this warranty is on all non-wear parts and limited to the replacement or repair of those products returned freight prepaid to Giant Industries which are deemed to be defective due to workmanship or failure of material. A Returned Goods Authorization (R.G.A.) number and completed warranty evaluation form is required prior to the return to Giant Industries of all products under warranty consideration. Call (419)-531-4600 or fax (419)-531-6836 to obtain an R.G.A. number.

Repair or replacement of defective products as provided is the sole and exclusive remedy provided hereunder and the MANUFACTURER SHALL NOT BE LIABLE FOR FURTHER LOSS, DAMAGES, OR EXPENSES, INCLUDING INCIDENTAL AND CONSEQUENTIAL DAMAGES DIRECTLY OR INDIRECTLY ARISING FROM THE SALE OR USE OF THIS PRODUCT.

THE LIMITED WARRANTY SET FORTH HEREIN IS IN LIEU OF ALL OTHER WARRANTIES OR REPRESENTATION, EXPRESS OR IMPLIED, INCLUDING WITHOUT LIMITATION ANY WARRANTIES OR MERCHANTABILITY OR FITNESS FOR A PARTICULAR PURPOSE AND ALL SUCH WARRANTIES ARE HEREBY DISCLAIMED AND EXCLUDED BY THE MANUFACTURER.



WARNING: This product might contain a chemical known to the State of California to cause cancer, and birth defects or other reproductive harm.

For more information go to www.P65Warnings.ca.gov

GIANT

Performance Under Pressure

GIANT INDUSTRIES, INC., 900 N. Westwood Ave., Toledo, Ohio 43607
PHONE (419) 531-4600, FAX (419) 531-6836, www.giantpumps.com
© Copyright 2022 Giant Industries, Inc.

02/22 P56HT_P56HTK_P56W-HK.indd