

# Models

Triplex Ceramic  
Operating Instructions/  
Manual

## P55W/P56W/P56W-0011/

## P56W-0021/P56W-0121

---

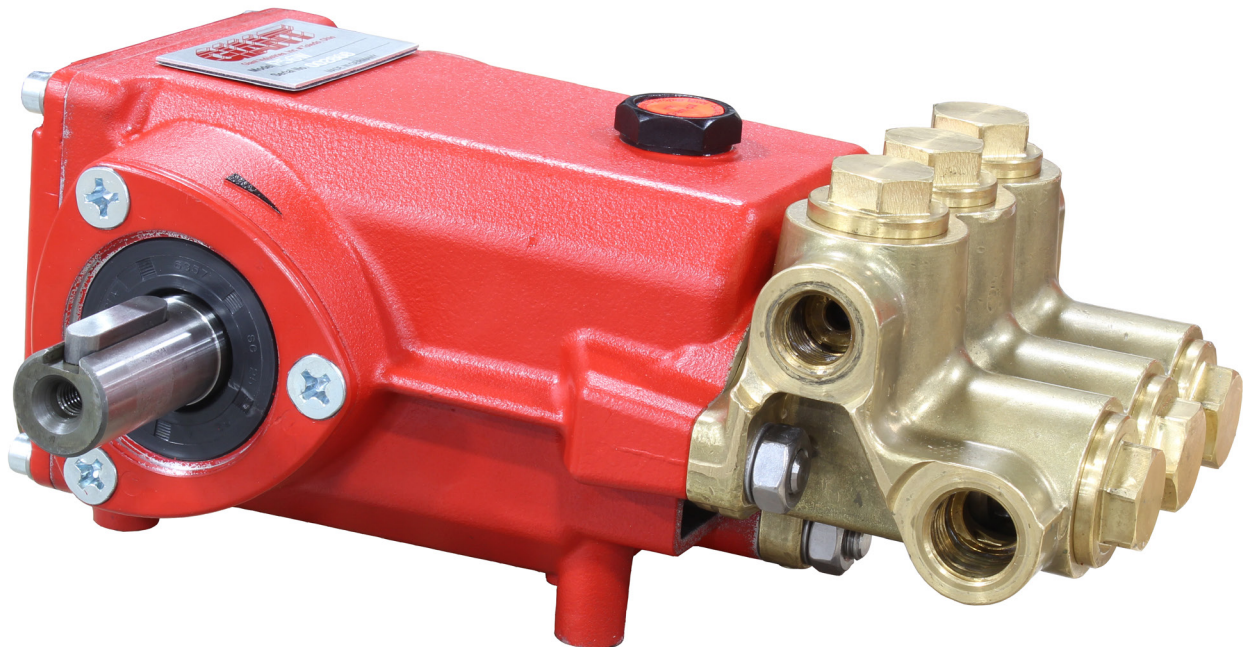

### Contents:

Installation Instructions:	page 2
Pump Specifications:	pages 3 & 7
Exploded View:	page 4
Parts List:	page 5
Kits:	page 6
Torque Specifications:	page 6
Trouble Shooting:	page 9
Repair Instructions:	page 8 - 11
Pump Mounting Selection Guide:	page 11
Recommended Spare Parts List:	page 11
Dimensions:	back page
Warranty Information:	back page

Updated 10/22

# Installation Instructions

## Operation and Maintenance

Check oil level prior to starting and ensure trouble-free water supply. Oil: Use only 12.5 ounces (0.37 litres) of Giant Oil (p/n 01154) or ISO VG 220 GL4 (e.g. Aral Degol BG220) or SAE 90 GL4 gear oil.

Initial change after 50 operating hours and then every 500 operating hours, after 6 months operation in any case. Caution when operating in damp places or with high temperature fluctuations.

Oil must be changed immediately, should condensate (frothy oil) occur in the gear box.

Keep NPSH under control.

Max. input pressure 145 PSI (10 bar), maximum suction head -4.35 (-0.3 bar).



### Safety Rules

Pump operation without safety valve as well as any excess in temperature or speed limits automatically voids the warranty. The safety valve must be regulated in accordance with the guidelines for liquid spraying units so that the admissible operating pressure can not be exceeded by more than 10%.

When the pump is in operation, the open shaft end must be covered up by shaft protector (17), the driven shaft side and coupling by a contact protector.

Pressure in discharge line and in pump must be at zero before any maintenance to the pump takes place. Close up suction line. Disconnect fuses to ensure that the driving motor does not get switched on accidentally.

Make sure that all parts on the pressure side of the unit are vented and refilled, with pressure at zero, before starting the pump.

In order to prevent air, or an air/water-mixture being absorbed and to prevent cavitation occurring, the pump-NPSHR, positive suction head and water temperature must be kept under control.

**Cavitation and/or compression of gases lead to uncontrollable pressure-kicks which can ruin pump and unit parts and also be dangerous to the operator or anyone standing nearby.**

Giant Plunger Pumps are suitable for pumping clean water and other non-aggressive or abrasive media with a specific weight similar to water.

**Before pumping other liquids - especially inflammable, explosive and toxic media - the pump manufacturer must under all circumstances be consulted with regard to the resistance of the pump material. It is the responsibility of the equipment manufacture and/or operator to ensure that all pertinent safety regulations are adhered to.**

## Specifications Model P55W

	U.S.....	Metric
Flow (Continuous).....	4.9 GPM.....	18.5 L/min
Max. Discharge Pressure (Continuous).....	2320 PSI.....	160 bar
Crankshaft Speed (Continuous).....		1420 RPM
Flow (Intermittent).....	6.0 GPM.....	22.7 L/min
Max. Discharge Pressure (Intermittent).....	1000 PSI.....	69 bar
Crankshaft Speed (Intermittent).....		1750 RPM
Power Consumption.....	7.8 BHP.....	5.8 kW
Maximum Inlet Pressure.....	-4.35 to 145 PSI.....	-0.3 to 10 bar
Maximum Temperature.....	160 °F.....	70 °C
Plunger Diameter.....	0.71".....	18 mm
Stroke.....	0.713".....	18.1 mm
Crankshaft Diameter.....		24 mm
Crankshaft Rotation.....	Top of Pulley Towards Fluid End	
Crankshaft Mounting.....	Either	
Inlet Ports.....	(2) 1/2" NPT	
Discharge Ports.....	(2) 3/8" NPT	
Crankcase Oil Capacity.....	12.5 fl.oz.....	370 ml
Weight.....	17.2 lbs.....	7.8 kg
Volumetric Efficiency @ 1420 RPM.....	0.94	
NPSHR.....	18.0 ft.-head.....	5.5 mWs

Required NPSH refers to water: Specific weight 1kg/dm<sup>3</sup>, viscosity 1°E at maximum permissible revolutions.

Consult the factory for special requirements that must be met if the pump is to operate beyond one or more of the limits specified above.

### PULLEY INFORMATION

Pulley selection and pump speed are based on a 1725 RPM motor and "B" section belts. When selecting desired GPM, allow for a ±5% tolerance on pumps output due to variations in pulleys, belts and motors among manufacturers.

1. Select GPM required, then select appropriate motor and pump pulley from the same line.
2. The desired pressure is achieved by selecting the correct nozzle size that corresponds with the pump GPM.

### HORSEPOWER INFORMATION

Horsepower ratings shown are the power requirements for the pump. Gas engine power outputs must be approximately twice the pump power requirements shown above.

We recommend that a 1.15 service factor be specified when selecting an electric motor as the power source. To compute specific pump horsepower requirements, use the following formula:

$$\frac{\text{GPM} \times \text{PSI}}{1450} = \text{hp}$$

<b>P55W PULLEY SELECTION &amp; HORSEPOWER REQUIREMENTS</b>							
PUMP PULLEY	MOTOR PULLEY	RPM	GPM	500 PSI	1000 PSI	2000 PSI	2320 PSI
7.75"	4.00"	851	2.9	1.0	2.0	4.0	4.6
7.75"	4.50"	967	3.3	1.1	2.3	4.5	5.2
7.75"	5.00"	1084	3.7	1.3	2.5	5.1	5.9
7.75"	5.50"	1201	4.1	1.4	2.8	5.6	6.5
7.75"	6.00"	1317	4.5	1.5	3.1	6.2	7.2
7.75"	6.45"	1420	4.9	1.7	3.4	6.7	7.8
7.75"	7.75"	1750	6.0	2.1	4.1		

**Exploded View -  
P55W/P56W/P56W-0011/P56W-0021/P56W-0121**

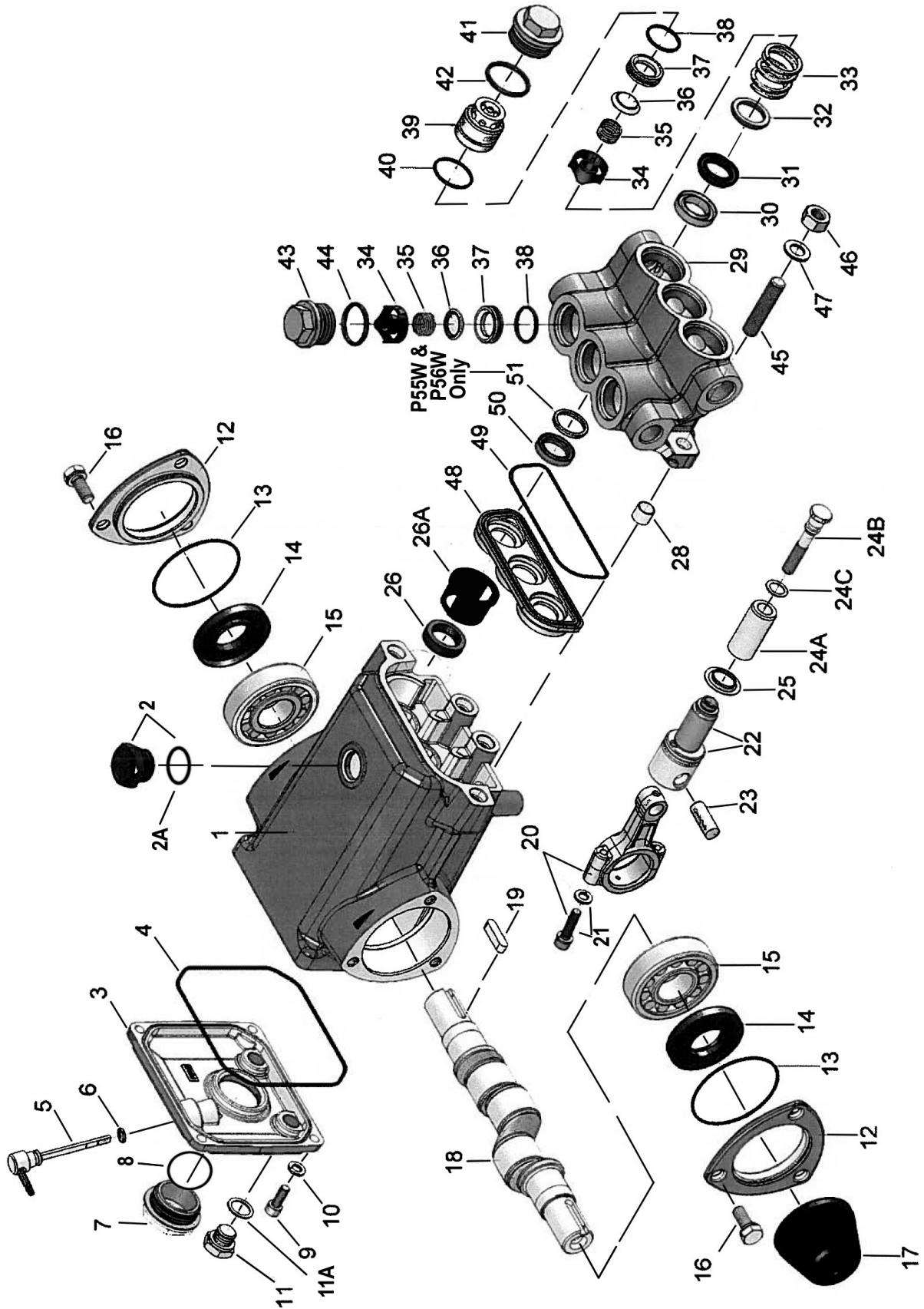



## Spare Parts List

### P55W/P56W/P56W-0011/P56W-0021/P56W-0121

<u>ITEM</u>	<u>PART</u>	<u>DESCRIPTION</u>	<u>QTY.</u>	<u>ITEM</u>	<u>PART</u>	<u>DESCRIPTION</u>	<u>QTY.</u>
1	07180	Crankcase	1	32	07209	Support Ring, P56	3
2	07181	Oil Filler Cap with Gasket	1	33	07210	Pressure Spring	3
2A	07182	Gasket, Oil Filler Cap	1	34	07325	Retainer, Spring	6
3	07183	Cover, Crankcase	1	35	06017-0100	Valve Spring	6
4	07184	O-Ring, Crankcase Cover	1	36	06016	Valve Plate	6
5	07185	Oil Dip Stick Assembly	1	37	06014	Valve Seat	6
6	01009	O-Ring, Dip Stick	1	38	06015	O-Ring, Valve Seat	6
7	07186	Oil Sight Glass	1	38	06015-0001	O-Ring, Viton, P56W-0011/-0021/-0121	6
8	07187	Gasket, Oil Sight Glass	1	39	07211	Adapter, Inlet Valve	3
9	07188	Screw, Crankcase Cover	4	40	07212	O-Ring, Adapter, P55W/P56W	3
10	07223-0100	Spring Washer	4	40	07212-0001	O-Ring, Viton P56W-0011/-0021/-0121	3
11	07190	Oil Drain Plug Assembly	2	41	07213	Plug, Manifold, Inlet	3
11A	13262	Gasket, Oil Drain Plug	2	42	07214	O-Ring, Manifold Plug, Inlet P55W/P56W	3
12	07192	Bearing Cover	2	42	07214-0001	O-Ring, Inlet Plug, Viton P56W-0011/-0021/-0121	3
13	07193	O-Ring, Bearing Cover	2	43	07792	Plug, Discharge	3
14	01166	Radial Shaft Seal	2	44	07035	O-Ring, Manifold Plug, Discharge P55W/P56W	3
15	01086	Ball Bearing	2	44	07035-0001	O-Ring, Discharge Plug, Viton P56W-0011/-0021/-0121	3
16	07196	Screw, Bearing Cover	6	45	07215	Stud, Manifold	4
17	05375	Shaft Protector	1	46	08040	Hex Nut, Manifold Stud	4
18	13330	Crankshaft	1	47	08041	Spring Washer, Stud	4
19	13331	Straight Key, 8mm	1	48	07017	Housing, Rear V-Sleeve, P55	1
20 <sup>1</sup>	07199	Connecting Rod Assembly	3	48	07036	Housing, Rear V-Sleeve, P56	1
21 <sup>1</sup>	01027	Conn. Rod Screw w/ Washer	6	49	07218	O-Ring, Rear V-Sleeve Housing P55W/P56W	1
22	07201	Plunger Base w/ S.S. Crosshead	3	49	07218-0001	O-Ring, Viton P56W-0011/-0021/-0121	1
23	01031	Crosshead Pin	3	50	06241	Grooved Seal Ring, Brown, P55W	3
24A	07021	Ceramic Plunger 18mm, P55	3	50	04615	Grooved Seal Ring, Brown, P56W	3
24A	06066	Ceramic Plunger, 20mm, P56	3	50	07039-0010	Rear V-Sleeve, Viton, P56W-0011	3
24B	08456	Tension Screw	3	50	07039-0020	Rear V-Sleeve, Teflon, P56W-0021/-0121	3
24C	07676	Copper Gasket	3	51	06242	Support Ring, White, P55	3
25	06648	Flinger	3	51	06240	Support Ring, White, P56 (except P56W-0011 & P56W-0021)	3
26	07206	Crankcase Oil Seal	3				
26A	07764	Spacer Sleeve	3				
28	07207	Shim, Manifold Stud	2				
29	07369-NPT	Manifold	1				
30	07010	Pressure Ring, P55	3				
30	07221	Pressure Ring, P56	3				
31	07011	V-Sleeve, P55W	3				
31	06076	V-Sleeve, P56W	3				
31	06064-0010	V-Sleeve, Viton, P56W-0011	3				
31	06064-0020	V-Sleeve, Teflon, P56W-0021/-0121	3				
32	07012	Support Ring, P55	3				

<sup>1</sup> Item #20 sold with item #21.

<sup>2</sup> For weep pumps manufactured prior to 7/00 consult earlier manuals (1/98 and before) for the correct parts in your pumps.

## Repair Kits

### P55W/P56W/P56W-0011/P56W-0021/P56W-0121

#### Plunger Packing Kit, P55W, #09089

<u>Item</u>	<u>Part #</u>	<u>Description</u>	<u>Qty.</u>
31	07011	V-Sleeve, Front	3
50	06241	Rear V-Sleeve	3
51	06242	Support Ring	3

#### Plunger Packing Kit, P56W, #09061

<u>Item</u>	<u>Part #</u>	<u>Description</u>	<u>Qty.</u>
31	06076	V-Sleeve, Front	3
50	04615	Rear V-Sleeve	3
51	06240	Support Ring	3

#### Plunger Packing Kit, P56W-0011, #09061-0011

<u>Item</u>	<u>Part #</u>	<u>Description</u>	<u>Qty.</u>
31	06064-0010	V-Sleeve, Viton	3
50	07039-0010	Rear V-Sleeve, Viton	3

#### Plunger Packing Kit, P56W-0021/P56W-0121 #09061-0021

<u>Item</u>	<u>Part #</u>	<u>Description</u>	<u>Qty.</u>
31	06064-0020	V-Sleeve, Teflon	3
50	07039-0020	Rear V-Sleeve, Teflon	3

#### Valve Assembly Kit, P55W/P56W - #09041

<u>Item</u>	<u>Part #</u>	<u>Description</u>	<u>Qty.</u>
34	07325	Retainer, Valve Spring	6
35	06017-0100	Valve Spring	6
36	06016	Valve Plate	6
37	06014	Valve Seat	6
38	06015	O-Ring, Valve Seat	6
40	07212	O-Ring, Adapter	3
42	07214	O-Ring, Inlet Plug	3
44	07035	O-Ring, Discharge Plug	3

#### Valve Assembly Kit, P56W-0011/P56W-0021/P56W-0121 #09041-0011

<u>Item</u>	<u>Part #</u>	<u>Description</u>	<u>Qty.</u>
34	07325	Retainer, Valve Spring	6
35	06017-0100	Valve Spring	6
36	06016	Valve Plate	6
37	06014	Valve Seat	6
38	06015-0001	O-Ring, Viton	6
40	07212-0001	O-Ring, Adapter, Viton	3
42	07214-0001	O-Ring, Inlet Plug, Viton	3
44	07035-0001	O-Ring, Discharge Plug, Viton	3

#### Oil Seal Kit, #09202

<u>Item</u>	<u>Part #</u>	<u>Description</u>	<u>Qty.</u>
26	07206	Crankcase Oil Seal	3

<b>Torque Specifications</b>				
<b>P55W/P56W/P56W-0011/P56W-0021/P56W-0121</b>				
<b>Position</b>	<b>Item#</b>	<b>Description</b>	<b>Lubrication Info</b>	<b>Torque Specifications</b>
7	07186	Oil Sight Glass	Loctite 5910	106 in.-lbs. (12 Nm)
9	07188	Screw, Crankcase Cover		22 ft.-lbs. (30 Nm)
11	07190	Oil Drain Plug Assembly		88 in.-lbs. (10 Nm)
16	07196	Screw, Bearing Cover		88 in.-lbs. (10 Nm)
20	07199	Connecting Rod Assembly		106 in.-lbs. (12 Nm)
24B	08456	Tension Screw	Loctite 243	200 in.-lbs. (22.5 Nm)
24C	07676	Copper Gasket	Loctite 243	
41	07213	Plug		51 ft.-lbs. (70 Nm)
43	07792	Plug, Discharge		51 ft.-lbs. (70 Nm)
46	08040	Hex Nut, Manifold Stud		35 ft.-lbs. (47.5 Nm)

# Specifications

## Models P56W/P56W-0011/P56W-0021/P56W-0121

	U.S. ....	Metric
Flow (Continuous).....	6.1 GPM.....	23.1 L/min
Max. Discharge Pressure (Continuous).....	1900 PSI .....	130 bar
Crankshaft Speed (Continuous) .....		1420 RPM
Flow (Intermittent).....	7.5 GPM.....	28 L/min
Max. Discharge Pressure (Intermittent).....	1000 PSI .....	69 bar
Crankshaft Speed (Intermittent).....		1750 RPM
Power Consumption .....	7.9 BHP .....	5.9 kW
Inlet Pressure.....	-4.35 to 145 PSI.....	-0.3 to 10 bar
Maximum Temperature (P56W).....	Up to 160 °F.....	70 °C
Plunger Diameter.....	0.787".....	20 mm
Stroke .....	0.713".....	18.1 mm
Crankshaft Diameter.....		24mm
Crankshaft Rotation.....	Top of Pulley Towards Fluid End	
Crankshaft Mounting.....	Either	
Inlet Ports.....	(2) 1/2" NPT	
Discharge Ports .....	(2) 3/8" NPT	
Crankcase Oil Capacity .....	12.5 fl.oz. ....	370 ml
Weight.....	17.2 lbs. ....	7.8 kg
Volumetric Efficiency @ 1420 RPM.....		0.94
NPSHR .....	24.3 ft.-head.....	7.4 mWw
Required NPSH refers to water: Specific weight 1kg/dm <sup>3</sup> , viscosity 1°E at maximum permissible revolutions.		

Consult the factory for special requirements that must be met if the pump is to operate beyond one or more of the limits specified above.

### PULLEY INFORMATION

Pulley selection and pump speed are based on a 1725 RPM motor and "B" section belts. When selecting desired GPM, allow for a ±5% tolerance on pumps output due to variations in pulleys, belts and motors among manufacturers.

1. Select GPM required, then select appropriate motor and pump pulley from the same line.
2. The desired pressure is achieved by selecting the correct nozzle size that corresponds with the pump GPM.

### HORSEPOWER INFORMATION

Horsepower ratings shown are the power requirements for the pump. Gas engine power outputs must be approximately twice the pump power requirements shown above.

We recommend that a 1.15 service factor be specified when selecting an electric motor as the power source. To compute specific pump horsepower requirements, use the following formula:

$$\frac{\text{GPM} \times \text{PSI}}{1450} = \text{hp}$$

<b>P56W/P56W-0011/P56W-0021/P56W-0121</b>							
<b>PULLEY SELECTION &amp; HORSEPOWER REQUIREMENTS</b>							
PUMP PULLEY	MOTOR PULLEY	RPM	GPM	500 PSI	1000 PSI	1500 PSI	1900 PSI
7.75"	4.00"	851	3.7	1.3	2.5	3.8	4.8
7.75"	4.50"	967	4.2	1.4	2.9	4.3	5.5
7.75"	5.00"	1084	4.7	1.6	3.2	4.8	6.2
7.75"	5.50"	1201	5.2	1.8	3.6	5.3	6.8
7.75"	6.00"	1317	5.7	2.0	3.9	5.9	7.5
7.75"	6.45"	1420	6.1	2.1	4.2	6.3	8.0
7.75"	7.75"	1750*	7.5	2.6	5.1		

\*Intermittent Duty Only

# Repair Instructions

## P55W/P56W/P56W-0011/P56W-0021/P56W-0121

**NOTE: Always take time to lubricate all metal and nonmetal parts with a light film of oil before reassembly. This step will ensure proper fit, at the same time protecting the pump nonmetal parts (i.e., the elastomers) from cutting and scoring.**

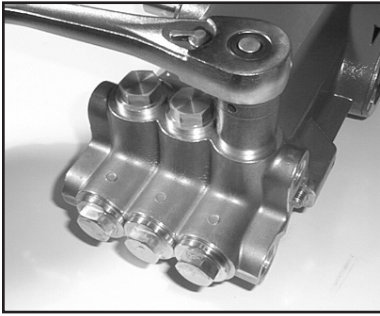

1. With a 22mm socket, remove the three discharge (43) and three inlet (41) manifold plugs. Check o-rings (42 and 44) for wear and replace as necessary.

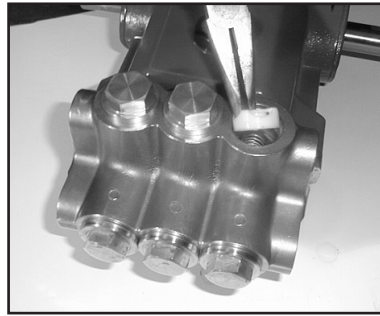

2. Remove the discharge spring retainer (34), valve spring (35), and valve plate (36).

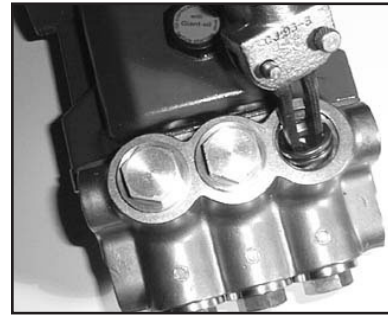

3. Using a small slide hammer remove valve seats (37) from manifold (29). Inspect valve plates (36) and valve seats (37) for wear. If excessive pitting is seen, replace the worn parts. Check valve seat o-ring (38) for wear and replace as necessary. Tighten manifold plugs (43) to 52 ft.-lbs. (70 Nm).

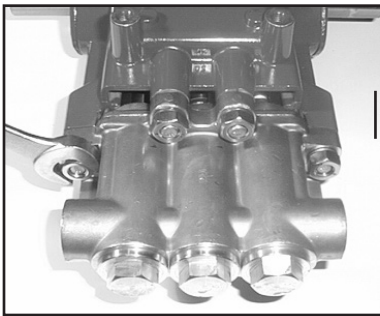

4. Drain the oil from the pump. Turn the pump over to remove the four manifold stud nuts (46) with a 17mm wrench.

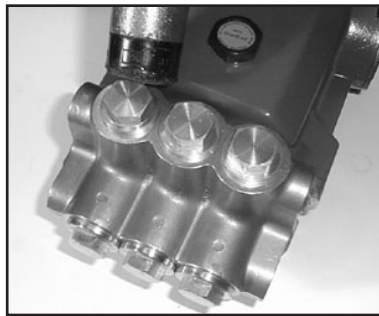

5. Tap the back of the manifold (29) with a rubber mallet to dislodge, and slide off the pump.

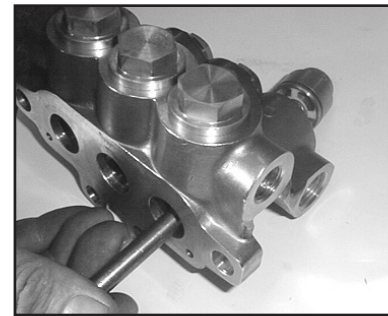

6. From the front inlet valve ports, remove the inlet valve assembly (34-40) and pressure springs (33).

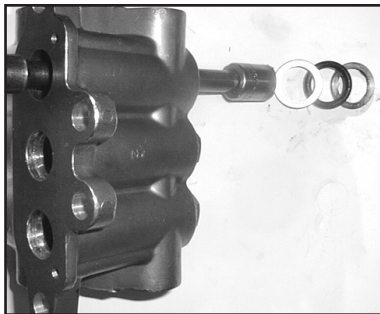

7. Turn the manifold (29) over. Using a 15mm socket, tap out the v-sleeves (31), support rings (32), and pressure rings (30) through back of manifold.

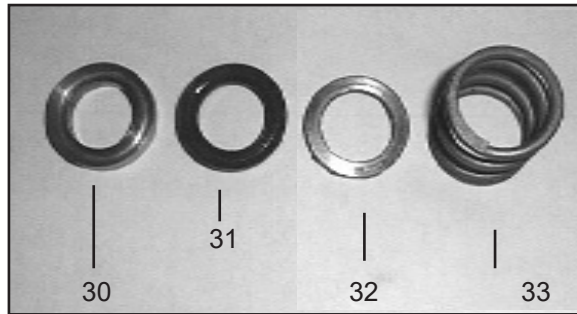

8. Inspect and clean the manifold (29) and pressure ring (32). Reinstall the pressure ring (30) with the grooved side pointed towards the front. Insert v-sleeves (31), support ring (32), and pressure spring (33) into the manifold.



## Repair Instructions

### P55W/P56W/P56W-0011/P56W-0021/P56W-0121

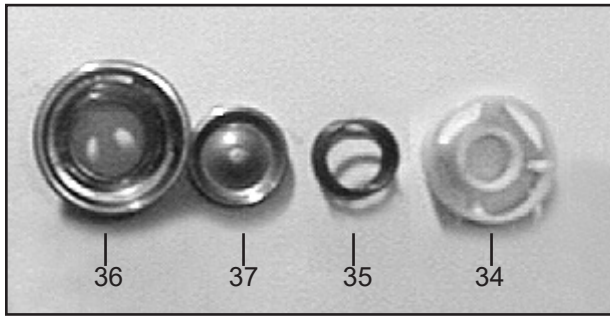

9. If pitted or worn, replace inlet valve seats (36), valve plates (37), springs (35) and spring retainers (34). Re-insert items 34-38 into valve adapter (39). Install valve assembly (34-40) into manifold (29). Reinstall manifold plugs (41) and torque plugs to 52 ft.-lbs. (70 Nm).

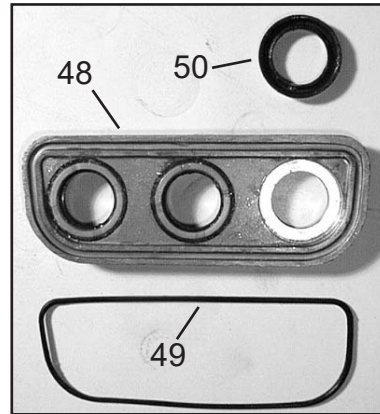

10. The rear v-sleeve housing (48) may be removed by prying evenly outward with a flat screwdriver. After slipping housing over ceramic plunger (24A), inspect seals (50) and o-ring (49) and replace as necessary. If the crankcase is to be disassembled, the housing should not be replaced until later.



11. Inspect ceramic plunger (24A) tips for wear. If necessary, replacement of the ceramic plungers may be accomplished by removing the plunger bolt assemblies (24B and 24C) with a 13mm wrench. Ceramic plungers should now slide off the stainless steel plunger base (22). Excessive resistance to plunger removal may be overcome by heating the stainless steel plunger base. This will melt any excess loc-tite beneath the ceramic plunger allowing easy removal.

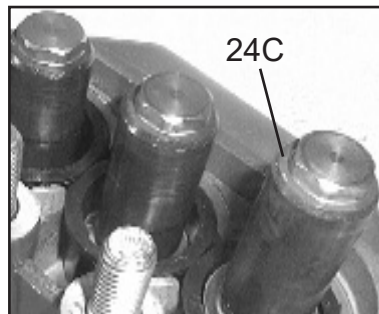

12. Replace copper ring (24C) onto plunger bolt (24B). Slide plunger bolt assembly into ceramic plunger (24A). Apply a light film of loc-tite to plunger bolt threads and place plunger assembly onto stainless steel plunger base (22) and tighten tension screw (24B) to 199 in.-lbs. (22.5 Nm).

13. To replace plunger oil seals (26), proceed to "Gear End Disassembly" section below. Otherwise, continue as described below.



14. Before replacing pump manifold (29), first rotate crankshaft (18) until two outside plungers (24A) extend evenly forward. Next lubricate v-sleeves (50) in the rear v-sleeve housing (48) and slide housing over plungers. Lubricate ceramic plungers with a light film of oil. Carefully and evenly slide manifold over plungers and press manifold firmly against crankcase (1). Replace manifold stud bolts (45), washers (47) and nut (46) and tighten to 35 ft.-lbs. (47.5 Nm).

# Repair Instructions

## P55W/P56W/P56W-0011/P56W-0021/P56W-0121

### Gear End Disassembly

**NOTE: The manifold (29) weep seal housing (48) and spacer sleeve (26A) must be removed. See above for directions.**

15. Remove the crankcase cover screws (9). Inspect the crankcase cover o-ring (4) for wear. Replace if necessary.
16. Inspect the dipstick (5) vent hole for signs of clogging. Clean if necessary.
17. To remove the crankshaft (18), first remove the bearing cover plates (12). Remove the key (19).
18. With a 5 mm allen wrench remove the connecting rod screws (21) and rear portion of connecting rod assemblies (20). Push the connecting rod (20) and plunger rod (22) down as far as possible into the crankcase housing.
19. Hold the pump rear assembly with a wooden fixture, or other suitable device, in order to secure it while removing the crankshaft (18). Using a plastic mallet, tap the crankshaft from one side while turning it from the other side. The turning insures that during this sequence the crankshaft does not become wedged against the front portion of the connecting rods (20). The far side bearing (15) will remain in the crankcase (1). When free, the crankshaft can be removed by hand. The opposite side crankshaft seal (14) will be removed by this procedure. **It is important that you turn the crankshaft (18) constantly while tapping from the opposite end to avoid any binding. The crankshaft bearing (15) remains on the crankshaft as it is removed.** If necessary, use a bearing puller to remove the crankshaft bearing (15).
20. Remove the front portion of the connecting rods (20) and plunger base assembly (22) from the rear of the pump by pulling straight out of the crankcase crosshead guides. **Notice that the connecting rod (20) halves are numbered or colored. Connecting rods must be positioned with their numbers or colors on the upper left-hand side, in the same numerical sequence as when they were removed.**
21. Using a dowel and a rubber mallet, tap the oil seals (26) out from the rear of crankcase (1). The area onto which the oil seal rests should be clean and dry. Put a small drop of loc-tite on the oil seals and place into crankcase with lips facing the rear of the pump.
22. To remove the crosshead pin (23) from the crosshead (22), the assembly should be positioned on a wooden fixture to avoid damage to crosshead. Drive out the pin on opposite side of mark located on the crosshead. On those pumps without mark on crosshead, drive out pin by tapping on tapered side of pin.
23. To remove the bearing (15) remaining in the crankcase (1), insert small end of Giant bearing tool (Tool-1) and tap with a rubber mallet until bearing and seal (14) are completely removed. **The bearing can only be removed from the inside by inserting the Giant Bearing Tool through the opposite side of the crankcase.** The crosshead guide in the crankcase should be inspected for possible damage.
24. To reassemble, place the far bearing (15) in the crankcase (1) bearing housing and with the Giant Bearing tool (Tool-1) as a driver, tap into the crankcase using a rubber mallet.
25. Insert the far side crankshaft oil seal (14) with the Giant Bearing Tool (Tool-1) making sure it is firmly seated and well oiled. Always make sure that the crankshaft seal lip does not show signs of wear and that the garter spring is firmly in place on the seal before reinserting into the pump. Replace the bearing cover (12) and o-ring (13) and tighten securely.

## Repair Instructions

### P55W/P56W/P56W-0011/P56W-0021/P56W-0121

26. Replace the front portion of the connecting rod (20) and plunger rod/ crosshead assembly (22) by press-fitting the crosshead pin (23). Make sure to insert the beveled edge of the crosshead pin into crosshead. If the crosshead has a mark, install pin from marked side. **The crosshead pin (23) should not extend beyond either side of the crosshead (22) in order to prevent damage to the crosshead bore of the crankcase (1).**
27. Place each crosshead/ plunger assembly into the pump making sure that all of the parts are well oiled before insertion into the crankcase (1). **Notice that the connecting rod (20) halves are numbered or colored. Connecting rods must be positioned with their numbers or colors on the upper left-hand side, in the same numerical sequence as when they were removed.**
28. Replace near side bearing (15) on crankshaft by using the Giant Bearing Tool (Tool-1) and mallet to tap into place. Take the crankshaft (18) end with the bearing (15) and insert the other end through the bearing housing and tap with a rubber mallet until the bearing is seated.
29. When reassembling the connecting rods (20), note that the connecting rod halves are numbered or colored and that the numbers or colors must be matched and aligned. Torque the connecting rod bolts to 125-150 in.-lbs.
30. Insert the near side crankshaft oil seal (14) with the Giant Bearing Tool (Tool-1) making sure it is firmly seated and well oiled. Replace the bearing cover (12) and o-ring (13) and tighten securely.

**See instructions above for re-installing fluid end onto the gear end.**

31. Fill the crankcase (1) with 12.5 oz. (370 mL) of Giant Industries' oil (p/n 01154) and check the oil level with the dipstick (5). Proper level is center of two lines. Reinstall the pump into your system.

### Preventative Maintenance Check-List & Recommended Spare Parts List

Check	Daily	Weekly	50hrs	Every 500 hrs	Every 1500 hrs	Every 3000 hrs
Oil Level/Quality	X					
Oil Leaks	X					
Water Leaks	X					
Belts, Pulley		X				
Plumbing		X				
Recommended Spare Parts						
Oil Change p/n 1154			X	X		
Plunger Packing Kits (1 kit/pump) (See page 6 for kit list)					X	
Valve Assembly Kit (1 kit/pump) (See page 6 for kit list)					X	
Oil Seal Kit (1 kit/pump) (See page 6 for kit list)						X

### Pump Mounting Selection Guide

<p><b>Bushings</b> 01074 - 24 mm Tapered H Bushing</p>	<p><b>Rails</b> 01034 - Steel Box Rails (L=9.25" x W=1.18" x H=1.62") 01075 - Plated Steel Channel Rails (L=9.00" x W=2.12" x H=2.50")</p>
<p><b>Pulley &amp; Sheaves</b> 01055 - 9.75" Cast Iron - 2 gr.-AB Section 01061 - 7.75" Cast Iron 1 gr. - AB Section 01062 - 7.75" Cast Iron - 2 gr. - AB Section</p>	

# P55W/P56W/P56W-0011/P56W-0021/P56W-0121

## Dimensions - INCHES (mm)

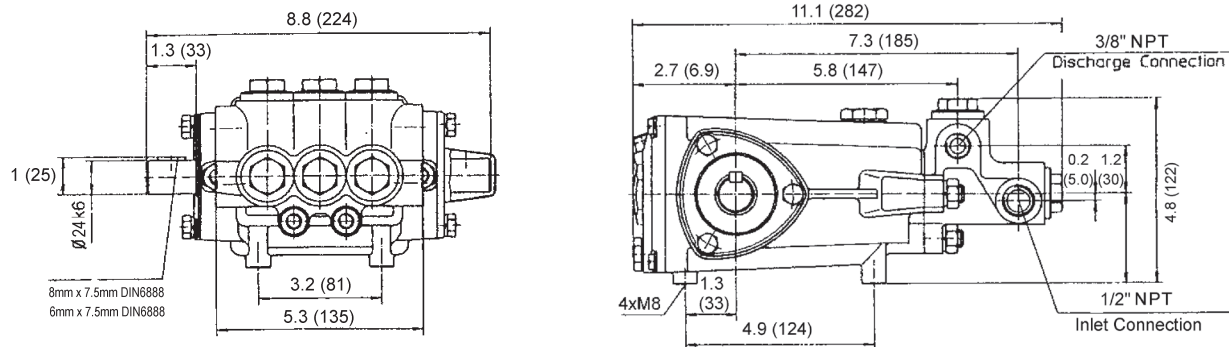

## GIANT INDUSTRIES LIMITED WARRANTY

Giant Industries, Inc. pumps and accessories are warranted by the manufacturer to be free from defects in workmanship and material as follows:

1. Five (5) years from the date of shipment for all pumps used in portable pressure washers with NON-SALINE, clean water applications.
2. Two (2) years from the date of shipment for Giant pumps used in car wash applications.
3. One (1) year from the date of shipment for all other Giant industrial and consumer pumps.
4. Six (6) months from the date of shipment for all rebuilt pumps
5. Ninety (90) days from the date of shipment for all Giant accessories.

This warranty is limited to repair or replacement of pumps and accessories of which the manufacturer's evaluation shows were defective at the time of shipment by the manufacturer. The following items are NOT covered or will void the warranty:

1. Defects caused by negligence or fault of the buyer or third party.
2. Normal wear and tear to standard wear parts.
3. Use of repair parts other than those manufactured or authorized by Giant.
4. Improper use of the product as a component part.
5. Changes or modifications made by the customer or third party.
6. The operation of pumps and or accessories exceeding the specifications set forth in the Operations Manuals provided by Giant Industries, Inc.

Liability under this warranty is on all non-wear parts and limited to the replacement or repair of those products returned freight prepaid to Giant Industries which are deemed to be defective due to workmanship or failure of material. A Returned Goods Authorization (R.G.A.) number and completed warranty evaluation form is required prior to the return to Giant Industries of all products under warranty consideration. Call (419)-531-4600 or fax (419)-531-6836 to obtain an R.G.A. number.

Repair or replacement of defective products as provided is the sole and exclusive remedy provided hereunder and the MANUFACTURER SHALL NOT BE LIABLE FOR FURTHER LOSS, DAMAGES, OR EXPENSES, INCLUDING INCIDENTAL AND CONSEQUENTIAL DAMAGES DIRECTLY OR INDIRECTLY ARISING FROM THE SALE OR USE OF THIS PRODUCT.

THE LIMITED WARRANTY SET FORTH HEREIN IS IN LIEU OF ALL OTHER WARRANTIES OR REPRESENTATION, EXPRESS OR IMPLIED, INCLUDING WITHOUT LIMITATION ANY WARRANTIES OR MERCHANTABILITY OR FITNESS FOR A PARTICULAR PURPOSE AND ALL SUCH WARRANTIES ARE HEREBY DISCLAIMED AND EXCLUDED BY THE MANUFACTURER.



**WARNING:** This product might contain a chemical known to the State of California to cause cancer, and birth defects or other reproductive harm.

For more information go to [www.P65Warnings.ca.gov](http://www.P65Warnings.ca.gov)

**GIANT**  
Performance Under Pressure

GIANT INDUSTRIES, INC., 900 N. Westwood Ave., Toledo, Ohio 43607  
PHONE (419) 531-4600, FAX (419) 531-6836, [www.giantpumps.com](http://www.giantpumps.com)  
© Copyright 2022 Giant Industries, Inc.