

Models

P47 & P48

Triplex Ceramic
Plunger Pump
Operating Instructions/
Repair and Service
Manual



GIANT
Performance Under Pressure

Contents:

Installation Instructions:	page 2
Pump Specifications:	page 3
Exploded View:	page 4
Parts List:	page 5
Kits/Torque Specs:	page 6
Pump Mounting Selection Guide:	page 6
Trouble Shooting:	page 7
Recommended Spare Parts List:	page 7
Repair Instructions:	page 8-10
Dimensions:	page 11
Warranty Information:	back page

Updated 10/21

INSTALLATION INSTRUCTIONS - P47 and P48 Pumps

Required NPSH refers to water: Specific weight 1kg/dm³, at maximum permissible revolutions.

Operation and Maintenance

Check oil level prior to starting and ensure trouble-free water supply.

IMPORTANT! If there is a **danger of frost**, the water in the pump and in the pump fittings (particularly the unloader valve) must be emptied. The second discharge port can also be used and the pump run “dry” for 1-2 minutes for this purpose.

Oil amount: 8.8 fl. oz. (0.26 litres). Only use ISO VG 220 industrial gear oil (e.g. Aral Degol BG220) or automobile gear oil SAE 90 GL4 (Giant’s p/n 01154).

Initial change after 50 operating hours and then every 1000 operating hours, after 1 year if used less.

Caution: When operating in damp places or with high temperature fluctuations, oil must be changed immediately (should condensate or frothy oil occur in the gear box).

Keep NPSH under control.

Maximum input pressure 145 PSI (10 bar), maximum suction head -4.35 PSI (-0.3 bar). Make sure that suction pulsation is sufficiently dampened – water column resonance must be avoided.

Field of Use

- hydrostatic testing of tanks and piping
- process technology
- high pressure injection-pump

Safety Rules

Pump operation without safety valve as well as any excess in temperature or speed limits automatically voids the warranty. The safety valve must be regulated in accordance with the guidelines for liquid spraying units so that the admissible operating pressure can not be exceeded by more than 10%.

When the pump is in operation, the open shaft end must be covered up by shaft protector (17), the driven shaft side and coupling by a coupling bell.

Before any maintenance to the pump takes place, pressure in discharge line and in pump must be at zero. Close up suction line. Disconnect fuses to ensure that the driving motor does not accidentally get switched on.

With pressure at zero and before starting the pump make sure that all parts on the pressure side of the unit are vented and refilled. In order to prevent air, or an air/water-mixture being absorbed and to prevent cavitation occurring, the pump-NPSHR, positive suction head and water temperature must be kept under control.

Cavitation and/or compression of gases lead to uncontrollable pressure-kicks which can ruin pump and unit parts and also be dangerous to the operator or anyone standing nearby.

Giant plunger pumps are suitable for pumping clean water and other non-aggressive or abrasive media with a specific weight similar to water.

Before pumping other liquids - especially inflammable, explosive and toxic media - the pump manufacturer must under all circumstances be consulted with regard to the resistance of the pump material. It is the responsibility of the equipment manufacture and/or operator to ensure that all pertinent safety regulations are adhered to.

Model P47 and P48 Specifications

	<u>US</u>	<u>Metric</u>
Volume (P47).....	1.2 GPM.....	4.7 L/min
Volume (P48).....	0.82 GPM.....	3.1 L/min
Discharge Pressure	3000 PSI*.....	200 Bar*
Inlet Pressure.....	-4.35 to 145 PSI.....	-0.3 to 10 Bar
Power Consumption (P47).....	2.5 BHP	1.9 kW
Power Consumption (P48).....	1.7 BHP	1.3 kW
Maximum Crankshaft Rotation Speed	Up to 1420 RPM	
Stroke	0.49".....	12.4mm
Crankcase Oil Capacity	8.8 fl. oz.	0.26 L
Temperature of Pumped Fluids.....	Up to 160°F	70°C
Plunger Diameter.....	0.47".....	12mm
Inlet Ports.....	(2) 1/2" BSP	
Discharge Ports	(2) 3/8" BSP	
Pulley Mounting	Either Side	
Shaft Rotation	Top of pulley towards Head	
Weight.....	14.3 lbs.	6.5 kg
Crankshaft Diameter.....	0.71".....	18mm
NPSHR (P47)	29.5 ft. of head.....	9.0 mWs

*Intermittent Duty Only

Consult the factory for special requirements that must be met if the pump is to operate beyond one or more of the limits specified above.

PULLEY INFORMATION

Pulley selection and pump speed are based on a 1725 RPM motor and "B" section belts. When selecting desired GPM, allow for a ±5% tolerance on pumps output due to variations in pulleys, belts and motors among manufacturers.

1. Select GPM required, then select appropriate motor and pump pulley from the same line.
2. The desired pressure is achieved by selecting the correct nozzle size that corresponds with the pump GPM.

HORSEPOWER INFORMATION

Horsepower ratings shown are the power requirements for the pump. Gas engine power outputs must be approximately twice the pump power requirements shown above.

We recommend that a 1.1 service factor be specified when selecting an electric motor as the power source. To compute specific pump horsepower requirements, use the following formula:

$$(GPM \times PSI) / 1450 = HP$$

P47 PULLEY SELECTION & HORSEPOWER REQUIREMENTS					
RPM	GPM	1000 PSI	2000 PSI	2500 PSI	3000 PSI*
900	0.8	0.6	1.1	1.4	1.7
1100	1.0	0.7	1.4	1.7	2.1
1200	1.1	0.8	1.5	1.9	2.3
1420	1.2	0.8	1.7	2.1	2.5

*Intermittent duty only

P48 PULLEY SELECTION & HORSEPOWER REQUIREMENTS					
RPM	GPM	1000 PSI	2000 PSI	2500 PSI	3000 PSI*
900	0.52	0.36	0.72	0.90	1.1
1100	0.64	0.44	0.88	1.1	1.3
1200	0.69	0.57	0.95	1.2	1.4
1420	0.82	0.57	1.1	1.4	1.7

*Intermittent duty only

Exploded View - P47 and P48

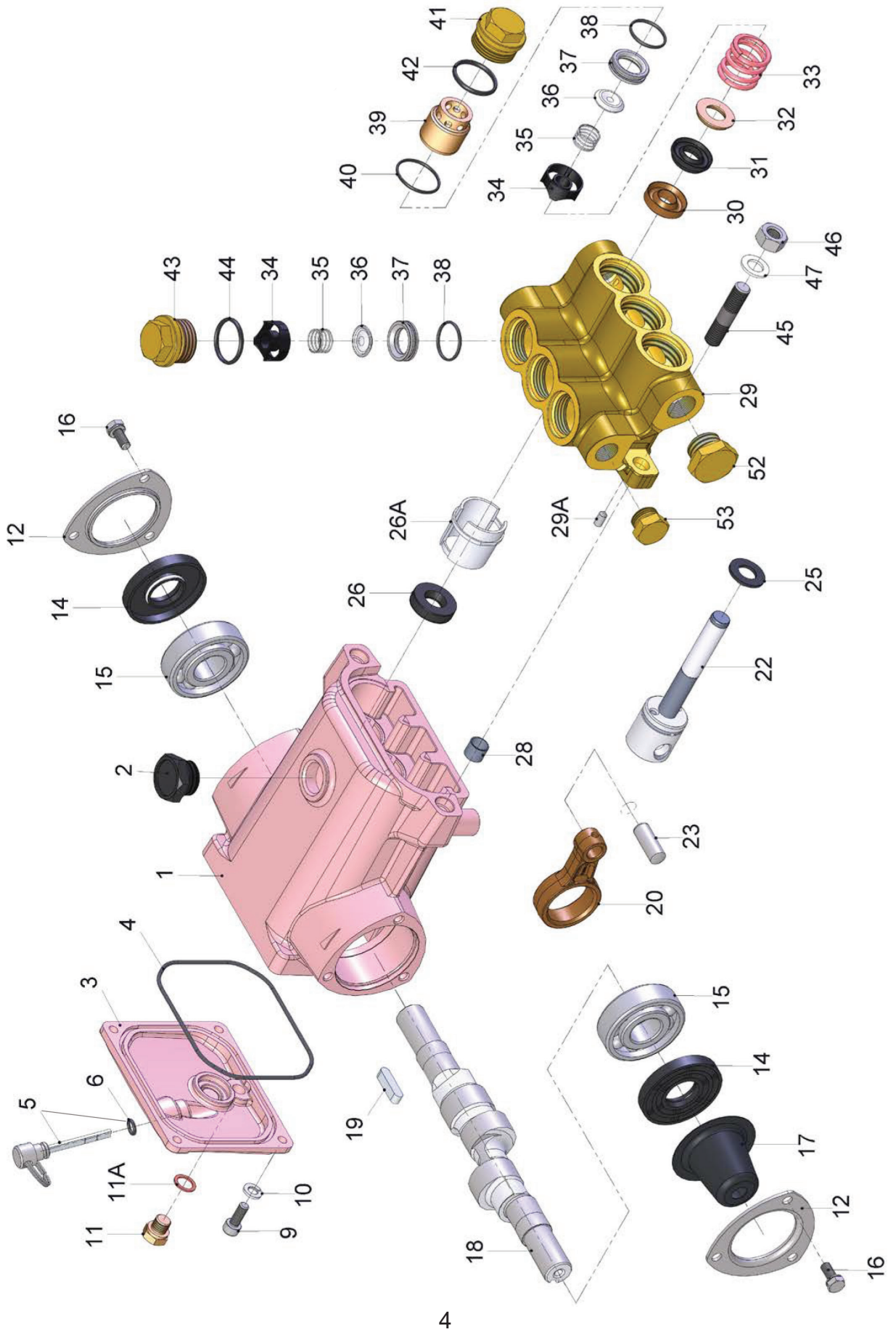

P47 and P48 PARTS LIST

<u>ITEM</u>	<u>PART</u>	<u>DESCRIPTION</u>	<u>QTY.</u>	<u>ITEM</u>	<u>PART</u>	<u>DESCRIPTION</u>	<u>QTY.</u>
1	07222	Crankcase	1	28	07207	Centring Sleeve	2
2	07181	Vent Plug with Seal	1	29	07033	Manifold	1
3	08004	Cover, Crankcase	1	29A	11502	Inner Hex Stud Bolt	2
4	08005	O-Ring	1	30	05514	Pressure Ring	3
5	08008	Oil Dipstick Assembly	1	31	08272	Sleeve	3
6	01009	O-Ring	1	32	05515	Sleeve Support Ring	3
9	07188	Cylinder Screw	4	33	07232	Pressure Spring	3
10	07223-0100	Spring Washer	4	34	07325	Spring Tension Disc	6
11	08012	Oil Drain Plug	1	35	08273	Valve Spring	6
11A	06709	Gasket, Oil Drain Plug	1	36	06016	Valve Plate	6
12	07224	Bearing Cover	2	37	06014	Valve Seat	6
14	08015	Radial Shaft Seal	2	38	06015	O-Ring	6
15	08020	Ball Bearing	2	39	07233	Suction Valve Adaptor	3
16	07225	Screw and Washer	6	40	07234	O-Ring	3
17	07226	Shaft Protector	1	41	07235	Plug, M28 x 1.5	3
18	08050	Crankshaft, P47	1	42	12004	O-Ring, Plug (Inlet)	3
18	03407	Crankshaft, P48	1	43	07792	Plug, 3/4" BSP	3
19	03385	Key	1	44	07035	O-Ring	3
20	08024	Connecting Rod	3	45	07215	Stud Bolt	2
22	07396	Plunger Assembly	3	46	08040	Hex Nut	2
23	01031	Crosshead Pin	3	47	08041	Disc	2
25	13403	Oil Scraper	3	52	07109	Plug, 1/2" BSP	1
26	08026	Radial Shaft Seal	3	53	13338	Plug, 3/8" BSP	1
26A	05513	Spacer Sleeve	3				

P47 and P48 REPAIR KITS

Plunger Packing Kit - #09758

<u>Item</u>	<u>Part #</u>	<u>Description</u>	<u>Qty.</u>
31	08272	Sleeve	3
40	07234	O-Ring	3
42	12004	O-Ring, Plug	3
44	07035	O-Ring	3

Valve Assembly Kit - #09759

<u>Item</u>	<u>Part #</u>	<u>Description</u>	<u>Qty.</u>
34	07325	Spring Tension Disc	6
35	08273	Valve Spring	6
36	06016	Valve Plate	6
37	06014	Valve Seat	6
38	06015	O-Ring	6

Oil Seal Kit - #09314

<u>Item</u>	<u>Part #</u>	<u>Description</u>	<u>Qty.</u>
25	13403	Oil Scraper	3
26	08026	Sleeve	3

P47 and P48 Pump Torque Specifications

<u>Position</u>	<u>Item</u>	<u>Description</u>	<u>Lubrication Info</u>	<u>Torque Amount</u>
9	07188	Cylinder Screw		88 in.-lbs. (10 Nm)
11	08012	Oil Drain Plug		132 in.-lbs. (15 Nm)
16	07225	Screw and Washer		88 in.-lbs. (10 Nm)
41	07235	Plug, M28 x 1.5		51 ft.-lbs. (70 Nm)
43	07792	Plug, 3/4" BSP	Loctite 243	51 ft.-lbs. (70 Nm)
46	08040	Hex Nut		35 ft.-lbs. (47.5 Nm)

PUMP SYSTEM MALFUNCTION

MALFUNCTION	CAUSE	REMEDY
The Pressure and/ or the Delivery Drops	Worn packing seals Broken valve spring Belt slippage Worn or Damaged nozzle Fouled discharge valve Fouled inlet strainer Worn or Damaged hose Worn or Plugged relief valve on pump Cavitation Unloader	Replace packing seals Replace spring Tighten or Replace belt Replace nozzle Clean valve assembly Clean strainer Repair/Replace hose Clean, Reset, and Replace worn parts Check suction lines on inlet of pump for restrictions Check for proper operation
Water in crankcase	High humidity Worn seals	Reduce oil change interval Replace seals
Noisy Operation	Worn bearings Cavitation	Replace bearings, Refill crankcase oil with recommended lubricant Check inlet lines for restrictions and/or proper sizing
Rough/Pulsating Operation with Pressure Drop	Worn packing Inlet restriction Accumulator pressure Unloader Cavitation	Replace packing Check system for stoppage, air leaks, correctly sized inlet plumbing to pump Recharge/Replace accumulator Check for proper operation Check inlet lines for restrictions and/or proper size
Pump Pressure as Rated, Pressure Drop at gun	Restricted discharge plumbing	Re-size discharge plumbing to flow rate of pump
Excessive Leakage	Worn plungers Worn packing/seals Excessive vacuum Cracked plungers Inlet pressure too high	Replace plungers Adjust or Replace packing seals Reduce suction vacuum Replace plungers Reduce inlet pressure
High Crankcase Temperature	Wrong Grade of oil Improper amount of oil in crankcase	Giant oil is recommended Adjust oil level to proper amount

Preventative Maintenance Check-List & Recommended Spare Parts List						
Check	Daily	Weekly	50hrs	Every 500 hrs	Every 1500 hrs	Every 3000 hrs
Oil Level/Quality	X					
Oil Leaks	X					
Water Leaks	X					
Belts, Pulley		X				
Plumbing		X				
Recommended Spare Parts						
Oil Change p/n 1154			X	X		
Plunger Packing Kits (1 kit/pump)*					X	
Valve Assembly Kit (1 kit/pump)*					X	
Oil Seal Kit (1 kit/pump)*					X	

*See page 5 for kit list

REPAIR INSTRUCTIONS - P47 and P48

To Check Valves

Suction Valve: Screw out plugs (41). Take out suction valve adaptor (39) together with suction valve. Push valve parts out of suction valve adaptor using a soft tool.

Check and replace worn parts.

Check O-rings (38,40,42) and replace as necessary.

Discharge Valve: Screw out plugs (43). Remove spring tension cap (34), valve spring (35) and valve plate (36) underneath. Take out valve seat (37) with a dia. 15mm pull-out device.

Check and replace worn parts.

Check O-rings (38,44) and replace as necessary.

Tighten plugs (41,43) to 51 ft.-lbs. (70NM).

To Check Seals and Plunger Pipe

Screw out plugs (41). Loosen nuts (46) and remove valve casing from plungers, pulling it out to the front. Take out suction valve adaptor (39), tension spring (33) and seal-unit (30,31,32). Check surfaces of plunger as damaged surfaces cause fast wear to the seals. When replacing V-sleeves (31), grease new seals with special grease from pump manufacturer before installing.

Check O-rings (40,42) and replace as necessary.

Check surface of plunger (22) for damage.

If the plunger (22) is worn, the whole plunger (22) including the crosshead must be changed (see section 'to dismantle gear' below).

Install tension spring (33) and suction valve adaptor (39), then tighten plug (41) to 51 ft.-lbs. (70NM).

Fix valve case by tightening nuts (46) evenly to 35 ft.-lbs. (47,5NM).

To Dismantle Gear

Drain oil after dismantling the valve casing (29), then screw off crankcase cover (3) and bearing cover (12).

Whilst turning slightly, hit out the crankshaft to one side with a rubber hammer. Do not force the cranks on the shaft when pulling through the connecting rod.

If necessary, either press out second bearing in crankcase or hit it out carefully with a soft tool.

Important! Connecting rods are marked for identification. Connecting rod is to be reinstalled in the same position on shaft journals.

Do not bend the connecting rod shanks. Check shaft and connecting rod surfaces, shaft seals (26), crosshead and plunger (22) and ball bearings.

If the plunger (22) is worn, pull out connecting rod and crosshead with plunger from behind. Hit out crosshead pin (23) using a knock-out tool. Fit new plunger with crosshead to connecting rod, then thread carefully through oiled radial shaft seal (26).

To Reassemble

Using a soft tool, press one ball bearing in till it reaches the edge of the bearing hole.

Push shaft with the other bearing in carefully through the opposite bearing hole and fit in carefully through the connecting rods.

Press on bearings on both sides.

Carefully thread shaft seal onto shaft and press into casing.

Fit on bearing cover (12).

Important! After assembly has been completed, the shaft should turn easily with very little clearance.

P47 and P48 DIMENSIONS - in [mm]

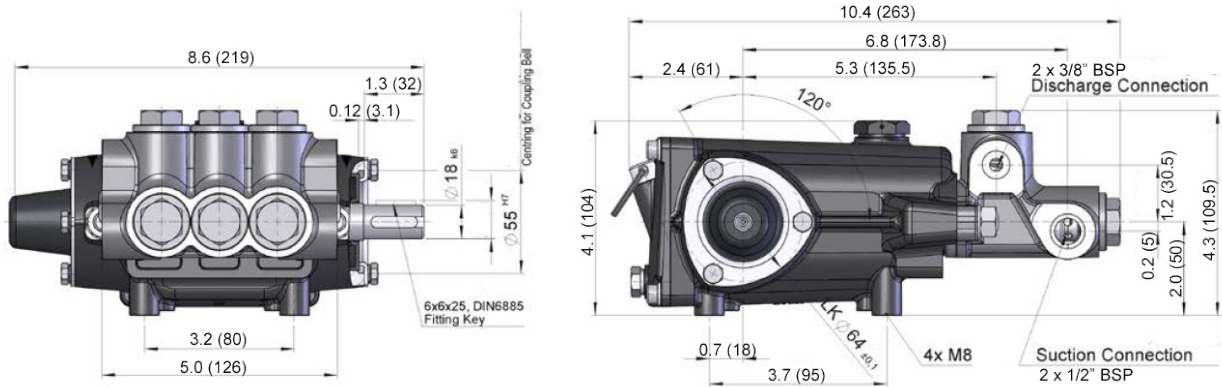

GIANT INDUSTRIES LIMITED WARRANTY

Giant Industries, Inc. pumps and accessories are warranted by the manufacturer to be free from defects in workmanship and material as follows:

1. Five (5) years from the date of shipment for all pumps used in portable pressure washers with NON-SALINE, clean water applications.
2. Two (2) years from the date of shipment for Giant pumps used in car wash applications.
3. One (1) year from the date of shipment for all other Giant industrial and consumer pumps.
4. Six (6) months from the date of shipment for all rebuilt pumps
5. Ninety (90) days from the date of shipment for all Giant accessories.

This warranty is limited to repair or replacement of pumps and accessories of which the manufacturer's evaluation shows were defective at the time of shipment by the manufacturer. The following items are NOT covered or will void the warranty:

1. Defects caused by negligence or fault of the buyer or third party.
2. Normal wear and tear to standard wear parts.
3. Use of repair parts other than those manufactured or authorized by Giant.
4. Improper use of the product as a component part.
5. Changes or modifications made by the customer or third party.
6. The operation of pumps and or accessories exceeding the specifications set forth in the Operations Manuals provided by Giant Industries, Inc.

Liability under this warranty is on all non-wear parts and limited to the replacement or repair of those products returned freight prepaid to Giant Industries which are deemed to be defective due to workmanship or failure of material. A Returned Goods Authorization (R.G.A.) number and completed warranty evaluation form is required prior to the return to Giant Industries of all products under warranty consideration. Call (419)-531-4600 or fax (419)-531-6836 to obtain an R.G.A. number.

Repair or replacement of defective products as provided is the sole and exclusive remedy provided hereunder and the MANUFACTURER SHALL NOT BE LIABLE FOR FURTHER LOSS, DAMAGES, OR EXPENSES, INCLUDING INCIDENTAL AND CONSEQUENTIAL DAMAGES DIRECTLY OR INDIRECTLY ARISING FROM THE SALE OR USE OF THIS PRODUCT.

THE LIMITED WARRANTY SET FORTH HEREIN IS IN LIEU OF ALL OTHER WARRANTIES OR REPRESENTATION, EXPRESS OR IMPLIED, INCLUDING WITHOUT LIMITATION ANY WARRANTIES OR MERCHANTABILITY OR FITNESS FOR A PARTICULAR PURPOSE AND ALL SUCH WARRANTIES ARE HEREBY DISCLAIMED AND EXCLUDED BY THE MANUFACTURER.



WARNING: This product might contain a chemical known to the State of California to cause cancer, and birth defects or other reproductive harm.
For more information go to www.P65Warnings.ca.gov

GIANT
Performance Under Pressure

GIANT INDUSTRIES, INC., 900 N. Westwood Ave., Toledo, Ohio 43607
PHONE (419) 531-4600, FAX (419) 531-6836, www.giantpumps.com
© Copyright 2021 Giant Industries, Inc.