

# Models

Triplex Ceramic  
Plunger Pump  
Operating Instructions/  
Repair and Service Manual

## P470/P490/P470-7000/P490-7000

---

P470/P490 - Forged Brass Manifold

P470-7000/P490-7000 - Nickel Plated Forged Brass Manifold

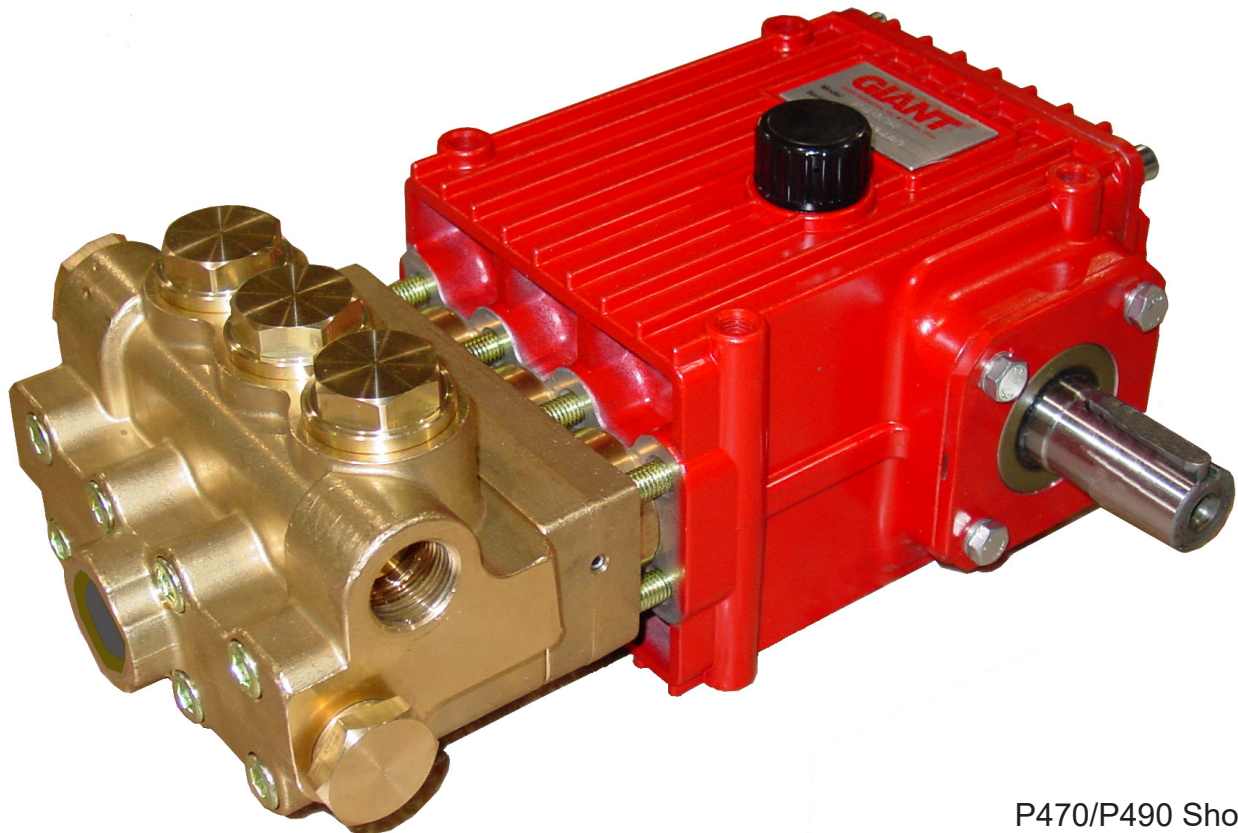

P470/P490 Shown

---

**GIANT**  
Performance Under Pressure

### Contents:

Installation Instructions:	page 2
Recommended Spare Parts List:	page 3
Pump Mounting Selection Guide:	page 3
Torque Specifications:	page 3
Pump Specifications-P470:	page 4
Pump Specifications-P490:	page 5
Exploded View:	page 6
Parts List / Kits:	page 7
Repair Instructions:	pages 8-10
Dimensions:	page 11
Warranty Information:	back page

Updated 05/23

# INSTALLATION INSTRUCTIONS

Required NPSH refers to water (specific weight  $1\text{kg/dm}^3$ , viscosity  $1^\circ\text{E}$ ) and maximum permissible pump revolutions.

## Operation and Maintenance

Check oil level prior to starting and ensure trouble-free water supply.

**Important!** If there is a danger of frost, the water in the pump and in the pump fittings (particularly the unloader valve) must be emptied. The second discharge port can be used and the pump run "dry" for 1-2 minutes for this purpose.

Oil: Use only 27.1 fluid ounces (0.8 liters) of ISO VG 220 GL4 (e.g. Aral Degol BG220) or SAE 90 GL4 gear oil (Giant p/n 01154).

Initial oil change after 50 operating hours and then every 500 hours, after 1 year if used less. Caution when operating in damp places or with high temperature fluctuations. Oil must be changed immediately should condensate (frothy oil) occur in the gear box.

### **NPSH values must be observed.**

Maximum input pressure 145 PSI (10 bar), maximum suction head -4.35 PSI (-0.3 bar). Make sure that suction pulsation is sufficiently dampened - water column resonance must be avoided.

**Important!** If the pump is not used for a long period of time, it is possible the seals (18/23) could become hard or brittle thus causing the pump to leak when put into operation.

If this is the case, we recommend these seals be replaced every 4 years.

## Safety Rules

A safety valve is to be installed in accordance with the guidelines for liquid spraying units so that the admissible operating pressure cannot be exceeded by more than 10%. Pump operation without a safety valve as well as any excess in temperature or speed limits automatically voids the warranty.

When the pump is in operation, the drive shaft end and the coupling must be enclosed by a protective cover or a coupling bell.

Pressure in the discharge line and pump must be at zero before any maintenance to the pump takes place. Close suction line. Disconnect fuses to ensure that the driving motor does not get switched on accidentally.

Make sure that all parts on the pressure side of the unit are vented before starting the pump. In order to prevent air, or an air-water mixture being absorbed and to prevent cavitation occurring, the pump NPSHR suction head and water temperature must be respected.

Cavitation and/or compression of gases lead to uncontrollable pressure kicks which can ruin pump and unit parts and also be dangerous to the operator or anyone standing nearby.

Giant Plunger Pumps are suitable for pumping clean water and other non-aggressive or non-abrasive media with a specific weight similar to water.

Before pumping other liquids - especially inflammable, explosive and toxic media - the pump manufacturer must be consulted with regard to the resistance of the pump material. It is the responsibility of the equipment manufacturer and/or operator to ensure that all pertinent safety regulations are adhered to.

# Specifications

## Model P470/P470-7000

	U.S.	METRIC
Volume .....	Up to 18.4 GPM.....	69.7 L/min
Discharge Pressure.....	Up to 2000 PSI .....	140 Bar
Max. Inlet Pressure .....	-4.35 to 145 PSI .....	-0.3 to 10 bar
Power Required .....	25.8 BHP .....	19.2 kW
Maximum Crankshaft Rotation Speed .....	Up to 1450 RPM	
Stroke.....	0.94" .....	24mm
Crankcase Oil Capacity.....	27.1 fl.oz.....	0.8 Liters
Temperature of Pumped Fluids .....	Up to 160 °F .....	70 °C
Plunger Diameter .....	1.18" .....	30mm
Inlet Ports .....	(1) x 1" BSPP* & (2) x 3/4" BSP	
Discharge Ports.....	(2) 3/4" BSP	
Pulley Mounting.....	Either Side <sup>1</sup>	
Shaft Rotation .....	Top of pulley towards fluid end	
Weight.....	39.7 lbs.....	18 kg
NPSHR.....	32.8 feet of head .....	10.0 meters of head

\* Recommended for inlet connection.

Consult the factory for special requirements that must be met if the pump is to operate beyond one or more of the limits specified above.

### PULLEY INFORMATION

Pulley selection and pump speed are based on a 1725 RPM motor and "B" section belts. When selecting desired GPM, allow for a ±5% tolerance on pumps output due to variations in pulleys, belts and motors among manufacturers.

1. Select GPM required, then select appropriate motor and pump pulley from the same line.
2. The desired pressure is achieved by selecting the correct nozzle size that corresponds with the pump GPM.

### HORSEPOWER INFORMATION

Horsepower ratings shown are the power requirements for the pump. Gas engine power outputs must be approximately twice the pump power requirements shown above.

We recommend that a 1.15 service factor be specified when selecting an electric motor as the power source. To compute specific pump horsepower requirements, use the following formula:

$$(GPM \times PSI) / 1450 = HP$$

P470 HORSEPOWER REQUIREMENTS						
RPM	GPM	500 PSI	750 PSI	1000 PSI	1500 PSI	2000 PSI
1000	12.7	4.4	6.6	8.8	13.1	17.5
1100	14.0	4.8	7.2	9.7	14.5	19.3
1200	15.2	5.2	7.9	10.5	15.7	21.0
1300	16.5	5.7	8.5	11.4	17.1	22.8
1450	18.4	6.3	9.5	12.7	19.0	25.4

**SPECIAL NOTE:**  
 The theoretical gallons per revolution (gal/rev) is 0.01269  
 To find specific outputs at various RPM, use the formula: GPM = 0.010743 x RPM

**<sup>1</sup>NOTE:** In order to drive the pump from the side opposite the present shaft extension, simply remove the valve casing from the crankcase and rotate the pumps 180 degrees to the desired position. Be certain to rotate the seal case (item #20) as well, so that the weep holes are down at the six o'clock position. Exchange the oil fill and the oil drain plugs, also. Refer to the repair instructions as necessary for the proper assembly sequence.

# Specifications

## Model P490/P490-7000

Continuous Ratings	U.S.	METRIC
Volume .....	15.7 GPM .....	59.5 L/min
Discharge Pressure.....	2000 PSI.....	140 Bar
Crankshaft Speed .....		1450 RPM
Power Required .....	13.0 BHP .....	9.7 kW

Intermittent Ratings		
Volume .....	18.9 GPM .....	71.7 L/min
Discharge Pressure.....	1000 PSI.....	69 bar
Crankshaft Speed .....		1750 RPM
Power Required .....	21.8 BHP .....	16.3 kW
Max. Inlet Pressure .....	145 PSI.....	10 bar
Maximum Crankshaft Rotation Speed .....		1450 RPM
Stroke.....	0.79" .....	20mm
Crankcase Oil Capacity.....	27.1 fl.oz.....	0.8 Liters
Temperature of Pumped Fluids.....	Up to 160 °F .....	70°C
Plunger Diameter .....	1.18" .....	30mm
Inlet Ports .....	(1) x 1" BSPP* & (2) x 3/4" BSP	
Discharge Ports.....	(2) 3/4" BSP	
Pulley Mounting.....	Either Side <sup>1</sup>	
Shaft Rotation .....	Top of pulley towards fluid end	
Weight.....	39.7lbs.....	18 kg
NPSHR.....	32.8 feet of head .....	10.0 meters of head

\* Recommend using this for inlet connection.

Consult the factory for special requirements that must be met if the pump is to operate beyond one or more of the limits specified above.

### PULLEY INFORMATION

Pulley selection and pump speed are based on a 1725 RPM motor and "B" section belts. When selecting desired GPM, allow for a ±5% tolerance on pumps output due to variations in pulleys, belts and motors among manufacturers.

1. Select GPM required, then select appropriate motor and pump pulley from the same line.
2. The desired pressure is achieved by selecting the correct nozzle size that corresponds with the pump GPM.

P490 HORSEPOWER REQUIREMENTS						
RPM	GPM	500 PSI	750 PSI	1000 PSI	1500 PSI	2000 PSI
1000	10.8	3.7	5.6	7.4	11.2	14.9
1100	13.0	4.5	6.7	9.0	13.4	17.9
1200	14.0	4.8	7.2	9.7	14.5	19.3
1450	15.7	5.4	8.1	10.8	16.2	21.7
1750	18.9	6.5	9.8	13.0		

**SPECIAL NOTE:**  
 The theoretical gallons per revolution (gal/rev) is 0.010743  
 To find specific outputs at various RPM, use the formula:  
 GPM = 0.010743 x RPM

### HORSEPOWER INFORMATION

Horsepower ratings shown are the power requirements for the pump. Gas engine power outputs must be approximately twice the pump power requirements shown above.

We recommend that a 1.15 service factor be specified when selecting an electric motor as the power source. To compute specific pump horsepower requirements, use the following formula:

$$(GPM \times PSI) / 1450 = HP$$

<sup>1</sup>NOTE: In order to drive the pump from the side opposite the present shaft extension, simply remove the valve casing from the crankcase and rotate the pumps 180 degrees to the desired position. Be certain to rotate the seal case (item #20) as well, so that the weep holes are down at the six o'clock position. Exchange the oil fill and the oil drain plugs, also. Refer to the repair instructions as necessary for the proper assembly sequence.

<b>Preventative Maintenance Check List &amp; Recommended Spare Parts List</b>						
<b>Check</b>	<b>Daily</b>	<b>Weekly</b>	<b>50 Hrs.</b>	<b>Every 500 Hours</b>	<b>Every 1500 Hours</b>	<b>Every 3000 Hours</b>
Oil Level/Quality	X					
Oil Leaks	X					
Water Leaks	X					
Belts, Pulley		X				
Plumbing		X				
<b>Recommended Spare Parts</b>						
Oil Change p/n 01154			X	X		
Plunger Seal Kit (1 kit/pump)*					X	
Oil Seal Kit (1 kit/pump)*					X	
Valve Repair Kit (1 kit/pump)*						X

\*See page 7 for kit list

### Pump Mounting Selection Guide

<p><b>Bushings</b> 07175 - 28mm Tapered H Bushing</p>	<p><b>Rails</b> 07358 - Plated Steel Channel Rails (L=9.18" x W=1.88" x H=3.00")</p>
<p><b>Pulley &amp; Sheaves</b> 01055 - 9.75" Cast Iron - 2 gr. AB 01062 - 7.75" Cast Iron - 2 gr. AB</p>	

### P470 / P490 Torque Specifications

<b>Item</b>	<b>Part #</b>	<b>Description</b>	<b>Lubrication Information</b>	<b>Torque Amount</b>
3A	07186	Oil Sight Glass/Gasket	Loctite 5910	106 in.-lbs. (12 Nm)
5	07109	Plug		59 ft.-lbs. (80 Nm)
5B	08092	Plug w/Gasket		59 ft.-lbs. (80 Nm)
6	01010	Screw		110 in.-lbs. (12.5 Nm)
10	07114	Screw with Washer		132 in.-lbs. (15 Nm)
15B	05249	Connecting Rod Screw		97 in.-lbs. (11 Nm)
16D	08399	Tension Screw	Loctite 243	21 ft.-lbs. (28 Nm)
32	06493	Plug	Loctite 243	125 ft.-lbs. (170 Nm)
34	06494	Cap Screw	Lightly Oil Threads	30 ft.-lbs. (40 Nm)

# Exploded View - P470/P470-7000/P490/P490-7000

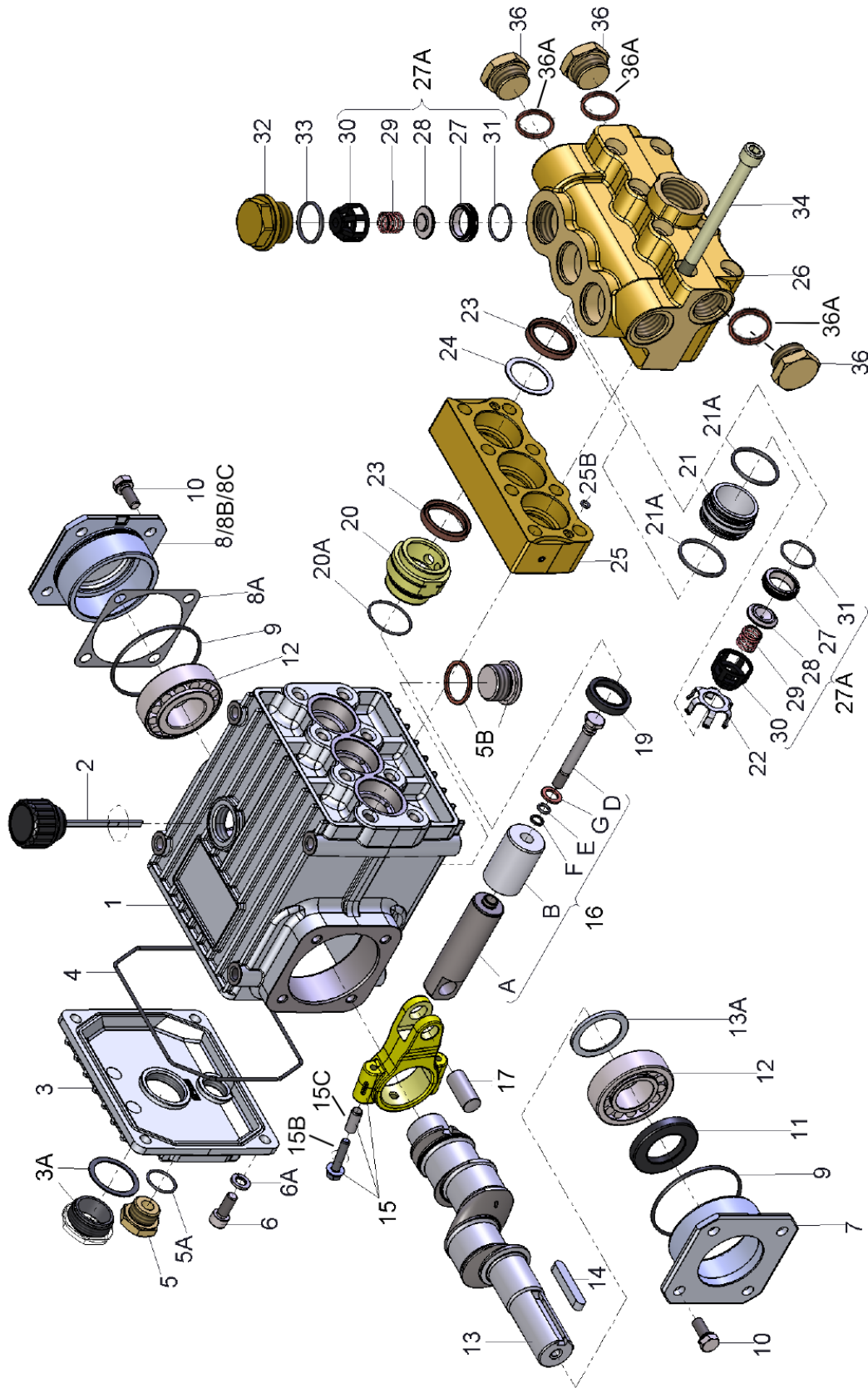

## P470/P470-7000/P490/P490-7000 PARTS LIST

<u>ITEM</u>	<u>PART</u>	<u>DESCRIPTION</u>	<u>QTY.</u>	<u>ITEM</u>	<u>PART</u>	<u>DESCRIPTION</u>	<u>QTY.</u>
1	08377	Crankcase	1	19	08366	Oil Seal	3
2	08378	Oil Fill Plug with Gasket	1	20	06928	Seal Adapter	3
3	06479	Crankcase Cover	1	20A	08059	O-Ring	3
3A	07186	Oil Sight Glass w/Gasket	1	21	06929	Seal Case	3
4	08380	O-Ring	1	21A	07150	O-Ring	6
5	07109	Oil Drain Plug	1	22	06930	Valve Holder	3
5A	06015	O-Ring	1	23	06931*	Grooved Seal	6
5B	08092	Plug with Gasket	1	24	06932	Support Ring	3
6	01010	Screw	4	25	06933	Intermediate Casing (P470/P490)	1
6A	01011-0400	Spring Washer	4	25	06933-7000	Intermediate Casing (P470-7000/P490-7000)	1
7	04739	Bearing Cover, Open	1	25A	05934	Thread Plug	2
8	05291	Bearing Cover, Closed	1	25B	02009	O-Ring	2
8A	05292	Shim, 0.1 mm	1-3	26	06935	Valve Casing (P470/P490)	1
8B	05293	Shim, 0.2 mm	1	26	06935-7000	Valve Casing (P470-7000/P490-7000)	1
8C	05964	Shim, 0.15 mm (may not be present)	1-2	27A	04365	Valve Assembly	6
9	01016	O-Ring	2	27	06937	Valve Seat	6
10	07114	Screw with Washer	8	28	06938	Valve Plate	6
11	07459	Radial Shaft Seal	1	29	06959	Valve Spring	6
12	05350	Bearing	2	30	06939	Valve Spring Retainer	6
13	04741	Crankshaft (P470)	1	31	07212	O-Ring	6
13	04740	Crankshaft (P490)	1	32	08373	Plug (P470/P490)	3
13A	04742	Spacer Ring	1	32	08373-0700	Plug (P470-7000/P490-7000)	3
14	08091	Fitting Key	1	33	07214	O-Ring	3
15	08390	Connecting Rod Assy.	3	34	06494	Cap Screw	8
15B	05349	Connecting Red Screw	3	36	07703	Plug, 3/4" BSP (P470/P490)	3
15C	05348	Adapter Sleeve	3	36	07703-0700	Plug, 3/4" BSP (P470-7000/P490-7000)	3
16	05933	Plunger Assembly	3	36A	04529	Copper Ring	3
16A	05352	Plunger Base	3				
16B	06927	Plunger Pipe	3				
16D	08399	Tension Screw	3				
16E	07023	O-Ring	3				
16F	07203	Support Ring	3				
16G	07258	Copper Gasket	3				
17	06790	Crosshead Pin	3				

**\*Important!** If the pump is not used for a long period of time, it is possible the seals (23) could become hard or brittle thus causing the pump to leak when put into operation. If this is the case we recommend these seals be replaced every 4 years.

## P470/P470-7000/P490/P490-7000 REPAIR KITS

### Plunger Packing Kit, #09565

<u>Item</u>	<u>Part #</u>	<u>Description</u>	<u>Qty.</u>
20A	08059	O-Ring	3
21A	07150	O-Ring	6
23	06931	Grooved Seal	6
24	06932	Support Ring	3
25B	02009	O-Ring	2

### Valve Assembly Kit, #09566

<u>Item</u>	<u>Part #</u>	<u>Description</u>	<u>Qty.</u>
27A	04365	Valve Assembly	6
31	07212	O-Ring	6
33	07214	O-Ring	3

### Oil Seal Kit, #09306

<u>Item</u>	<u>Part #</u>	<u>Description</u>	<u>Qty.</u>
19	08366	Oil Seal	3

# REPAIR INSTRUCTIONS - P470/P470-7000/P490/P490-7000 PUMPS

## To Check Valves

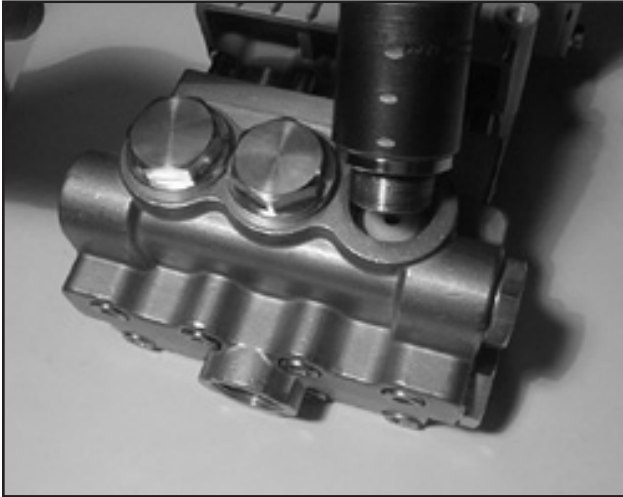

1. Remove plugs (32) with socket wrench.

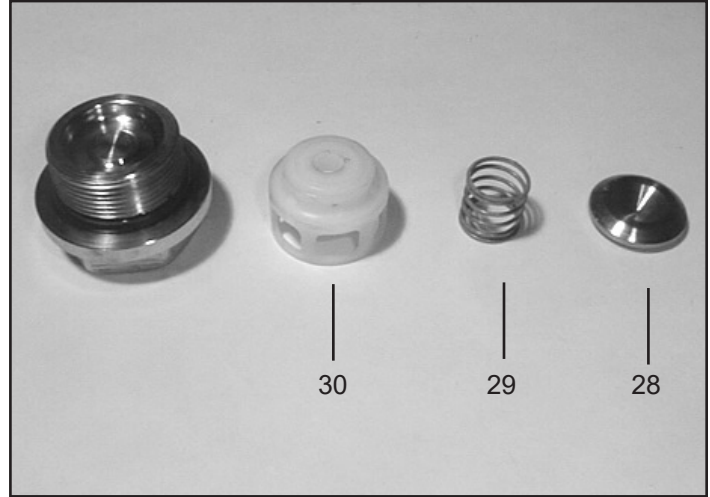

2. Remove the exposed spring tension cap (30) from valve seat by pushing it sideways with a screwdriver. Remove spring tension cap (30), valve spring (29), and valve plate (28).

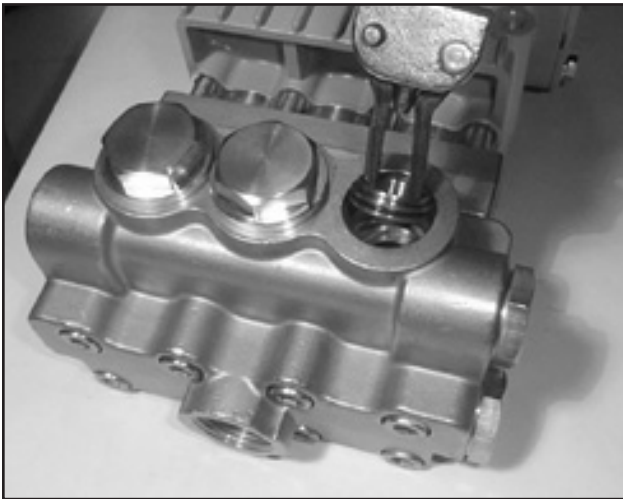

3. Pull out valve seat (27) and O-ring (31) with a valve puller. Check O-ring for wear.

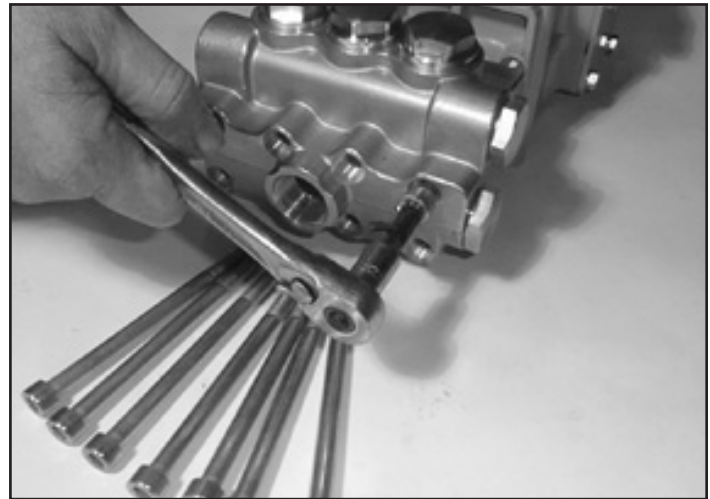

4. Remove hexagon socket screws (34) and remove valve casing (26) by pulling them front-wise over the plungers (16).



# REPAIR INSTRUCTIONS - P470/P470-7000/P490/P490-7000 PUMPS

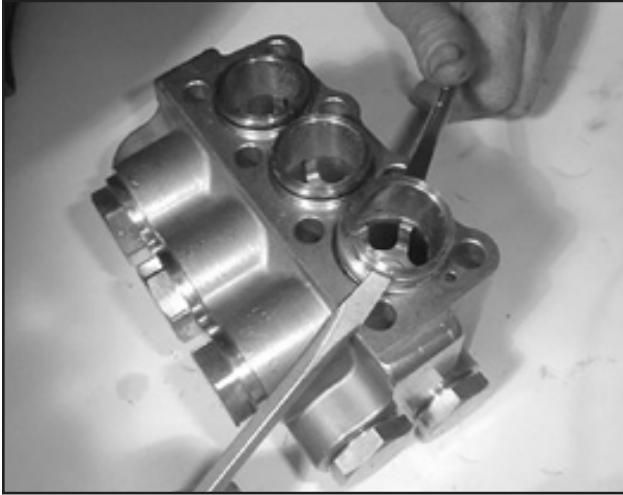

5. Using two screwdrivers, remove seal case (21) out of the valve casing (26) or intermediate casing (25).

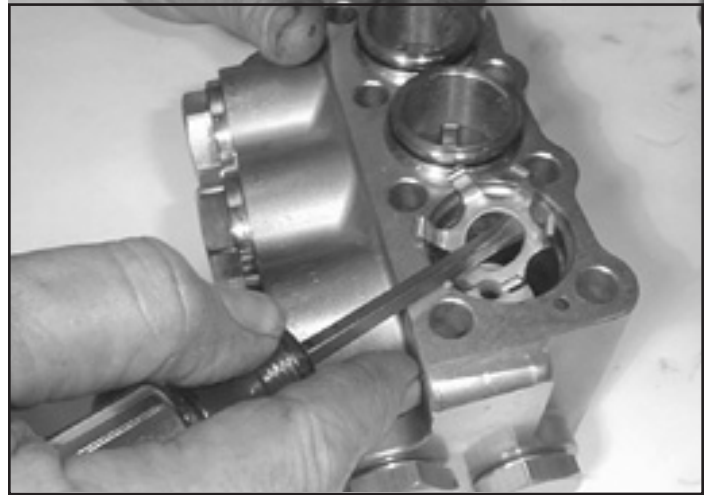

6. The exposed suction valve parts are to be removed the same way as the discharge valves as described above. Check valve components for wear and damage. Check O-rings (21A, 31, 33). Replace worn parts. Reassemble in same order. Coat new o-rings with oil before installation. Coat O-rings (25B) with silicon grease and place them in their recesses. Insert seal cases (21) into valve casing (26) before mounting the whole unit. Slide valve casing (26) over plungers. Tighten hexagon socket screws (34) crosswise and evenly at 36 ft-lbs. Tighten plugs (32) at 125 ft.-lbs. (170 Nm).

**Important:** When extracting the valve holders (22), make sure not to scratch the outer bore diameter as this is a sealing.

## To Check To Check Seals and Plunger Pipe

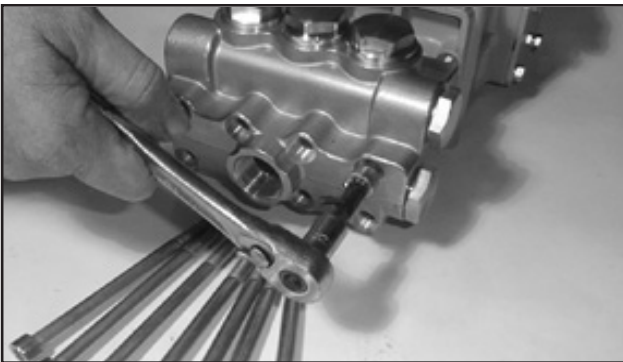

7. Remove hexagon socket screws (34) and remove valve casing (26) by pulling them frontwise over the plungers (16).



8. Using two screwdrivers, gently pry seal cases (21) out of the valve casing (26) or intermediate casing (25). Press grooved rings (23) and support rings (24) out of intermediate casing (25) using a screwdriver. Check O-rings (21A/25B). Examine seals (23). Replace worn seals.

# REPAIR INSTRUCTIONS - P470/P470-7000/P490/P490-7000 PUMPS

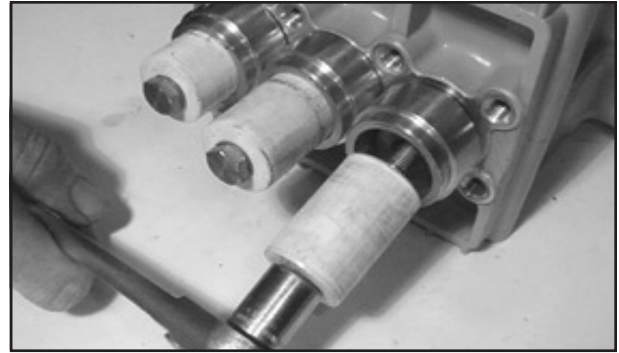
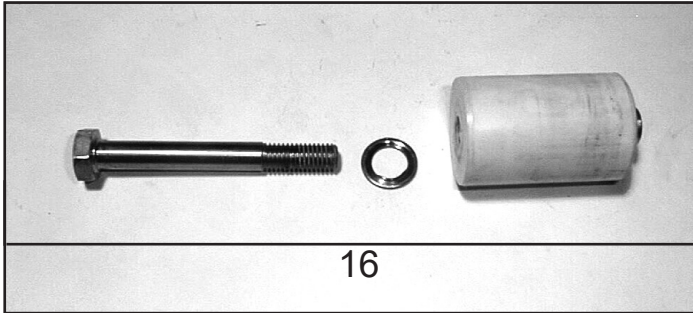

9. Check plunger surfaces (16). Damaged surfaces lead to accelerated seal wear. Deposits of all kinds must be removed from the plungers.

**Important:** Plunger surfaces are not to be damaged. If there are lime desposits in the pump, care must be taken that the weep-return bore in parts (25) and (26) ensure trouble-free weep-return.

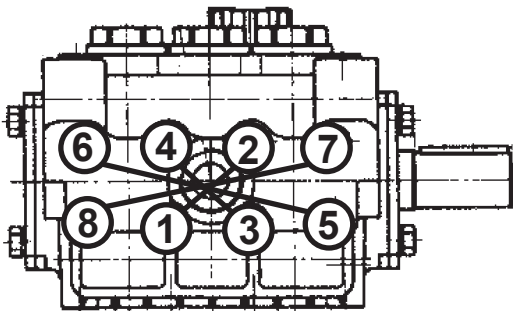

10. If the plunger pipe (16B) is worn, remove tension screw (16D) and remove together with plunger pipe. Check and clean plunger (16A) surfaces and mount new plunger pipe. Cover thread of tension screw (16D) with a thin film of Loctite and tighten carefully at 248 in.-lbs. (28 Nm).

**Important:** Glue must never come between the plunger pipe (16B) and the centring sleeve (16C). The plunger pipe is not to be strained by eccentric tightening of the tension screw or through damage to the front surface as this can lead to breakage.

11. When reassembling, tighten inner hexagon screw (34) at 30 ft.-lbs. (40 Nm) in a crossing pattern (as shown on left).

## Gear and Plunger

If oil leaks where the plungers (16) protrude out of the gear, gear seals (19) and plungers must be examined and replaced if necessary.

- Gear Seal:** Remove oil plug (5) and drain oil. Remove valve casing (26) together with seal casing (25) as described above. Dismantle plunger pipe (16B). Pry gear seal adaptor (20) out of the crankcase using a screwdriver; take out gear seal (19) and replace it.
- Plungers:** Remove oil plug (5) and drain oil; remove crankcase cover (3). Remove valve casing (26), seal casing (25), gear seal adaptors (20) and plunger pipes (16B) as described above. Remove screws on conn-rods (15). Be careful not to mix up the connecting rod halves. Push connecting rod shaft as far as possible into the crosshead guide. Take off screws (10) and pry out bearing covers (7 & 8) with the help of a screwdriver. Take out crankshaft carefully threading it past the conrods (15), making sure not to bend the connecting rods. Remove and dismantle connecting rods and plungers (16). Replace worn parts. Reassemble and tighten tension screws (16D) at 248 in.-lbs. (28 Nm). When reinstalling, first insert connecting rods together with plungers. Thread in crankshaft. Then push bearing covers (7 & 8) onto the crankshaft ends. Screw on bearing covers with screws (10). Mount connecting rod halves and tighten screws (15) at 22 ft.-lbs. Mount crankcase cover (3) together with O-ring (4). Replace seal adaptors (20), seal casing (25) and valve casing (26). Replace eight (8) hexagon screws (34) and tighten to 30 ft.-lbs. (40 Nm).

**MODEL P470/P470-7000/P490/P490-7000 DIMENSIONS - INCHES (mm)**

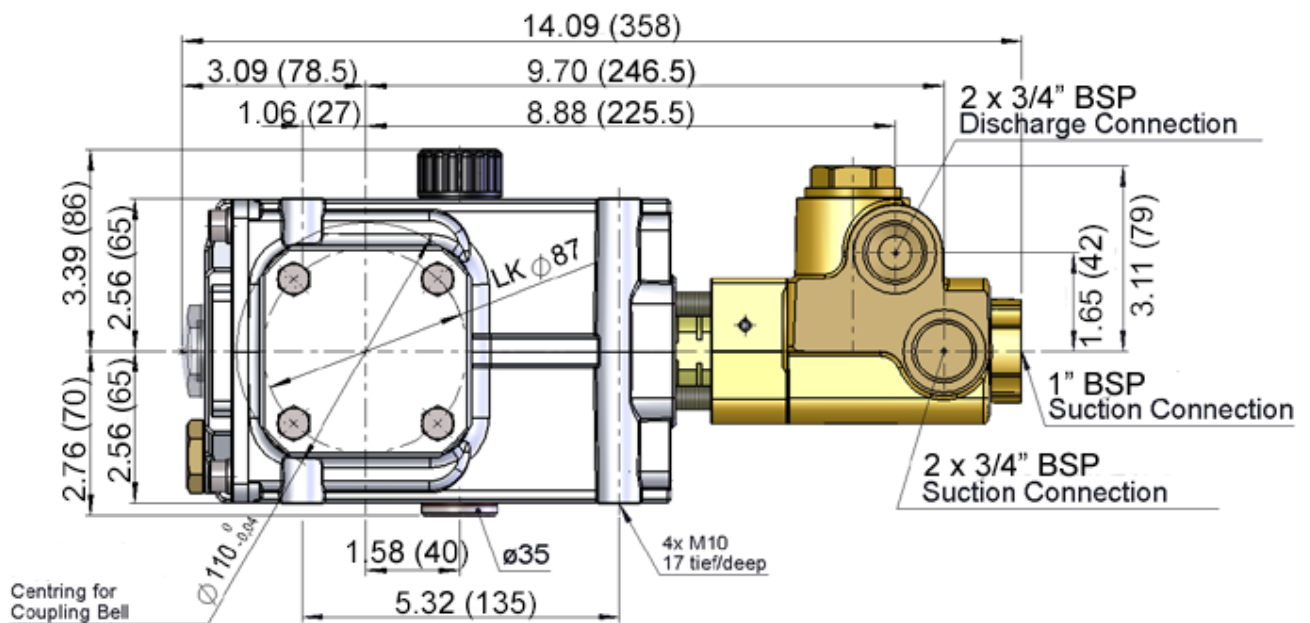
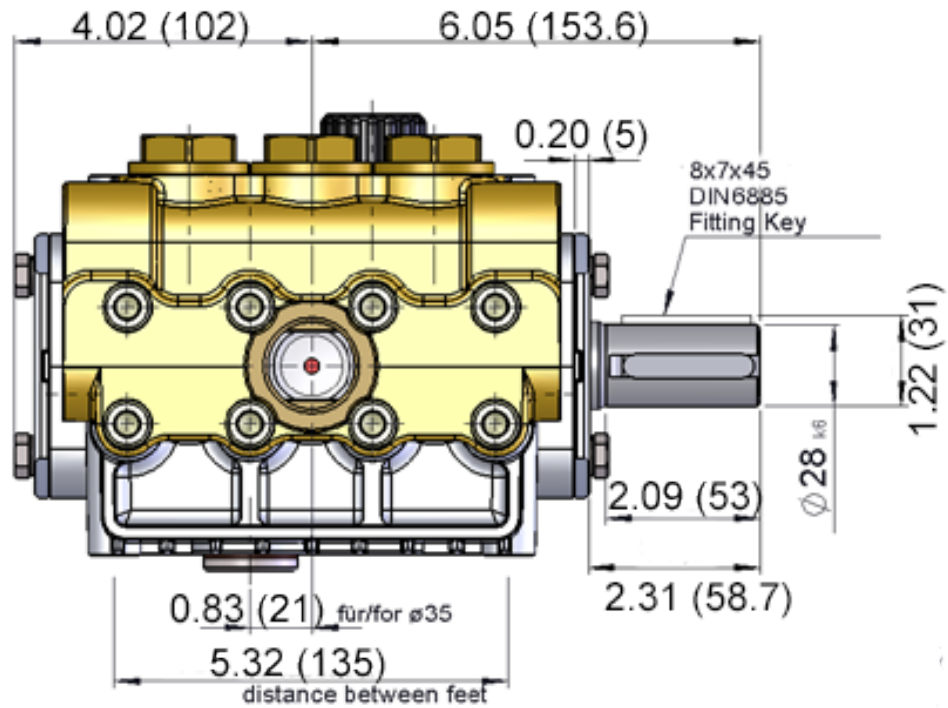

## GIANT INDUSTRIES LIMITED WARRANTY

Giant Industries, Inc. pumps and accessories are warranted by the manufacturer to be free from defects in workmanship and material as follows:

1. Five (5) years from the date of shipment for all pumps used in portable pressure washers with NON-SALINE, clean water applications.
2. Two (2) years from the date of shipment for Giant pumps used in car wash applications.
3. One (1) year from the date of shipment for all other Giant industrial and consumer pumps.
4. Six (6) months from the date of shipment for all rebuilt pumps
5. Ninety (90) days from the date of shipment for all Giant accessories.

This warranty is limited to repair or replacement of pumps and accessories of which the manufacturer's evaluation shows were defective at the time of shipment by the manufacturer. The following items are NOT covered or will void the warranty:

1. Defects caused by negligence or fault of the buyer or third party.
2. Normal wear and tear to standard wear parts.
3. Use of repair parts other than those manufactured or authorized by Giant.
4. Improper use of the product as a component part.
5. Changes or modifications made by the customer or third party.
6. The operation of pumps and or accessories exceeding the specifications set forth in the Operations Manuals provided by Giant Industries, Inc.

Liability under this warranty is on all non-wear parts and limited to the replacement or repair of those products returned freight prepaid to Giant Industries which are deemed to be defective due to workmanship or failure of material. A Returned Goods Authorization (R.G.A.) number and completed warranty evaluation form is required prior to the return to Giant Industries of all products under warranty consideration. Call (419)-531-4600 or fax (419)-531-6836 to obtain an R.G.A. number.

Repair or replacement of defective products as provided is the sole and exclusive remedy provided hereunder and the MANUFACTURER SHALL NOT BE LIABLE FOR FURTHER LOSS, DAMAGES, OR EXPENSES, INCLUDING INCIDENTAL AND CONSEQUENTIAL DAMAGES DIRECTLY OR INDIRECTLY ARISING FROM THE SALE OR USE OF THIS PRODUCT.

THE LIMITED WARRANTY SET FORTH HEREIN IS IN LIEU OF ALL OTHER WARRANTIES OR REPRESENTATION, EXPRESS OR IMPLIED, INCLUDING WITHOUT LIMITATION ANY WARRANTIES OR MERCHANTABILITY OR FITNESS FOR A PARTICULAR PURPOSE AND ALL SUCH WARRANTIES ARE HEREBY DISCLAIMED AND EXCLUDED BY THE MANUFACTURER.



**WARNING:** This product might contain a chemical known to the State of California to cause cancer, and birth defects or other reproductive harm.  
For more information go to [www.P65Warnings.ca.gov](http://www.P65Warnings.ca.gov)