

Models

P46W, P46W-HK,

P46HT, P49W & P49W-HK

Triplex Ceramic
Plunger Pump
Operating Instructions/
Repair and Service
Manual



Contents:

Installation Instructions:	page 2
Pump Specifications:	page 3-5
Exploded View:	page 6
Parts List:	page 6
Kits/Torque Specs:	page 7
Pump Mounting Selection Guide:	page 7
Trouble Shooting:	page 8
Recommended Spare Parts List:	page 8
Repair Instructions:	page 9-11
Dimensions:	back page
Warranty Information:	back page

Updated 10/22

INSTALLATION INSTRUCTIONS - P46W, P46W-HK, P46HT, P49W & P49W-HK

Operation and Maintenance

Check oil level prior to starting and ensure trouble-free water supply.

Important! If there is a **danger of frost**, the water in the pump and in the pump fittings (particularly the unloader valve) must be emptied. The pump can be run “dry” for 1-2 minutes for this purpose.

Oil: Use only 8.8 ounces (0.26 litres) of Giant Oil (p/n 01154) or ISO VG 220 GL4 (e.g. Aral Degol BG220) or SAE 90 GL4 gear oil.

Initial change after 50 operating hours and then every 500 operating hours, after 6 months operation in any case.

Caution! When operating in damp places or with high temperature fluctuations. Should condensate (frothy oil) occur in the gear box, oil must be changed immediately.

Keep NPSH under control.

Max. input pressure 145 PSI (10 bar), maximum suction head -4.35 PSI (-0.3 bar).

Safety Rules

Pump operation without safety valve as well as any excess in temperature or speed limits automatically voids the warranty. The safety valve must be regulated in accordance with the guidelines for liquid spraying units so that the admissible operating pressure can not be exceeded by more than 10%.

When the pump is in operation, the open shaft end must be covered up by shaft protector (17), the driven shaft side and coupling by a contact protector.

Pressure in discharge line and in pump must be at zero before any maintenance

to the pump takes place. Close suction line. Disconnect fuses to ensure that the driving motor does not accidentally switch on. Make sure that all parts on the pressure side of the unit are vented and re-filled, with pressure at zero, before starting the pump. In order to prevent air, or an air/water-mixture being absorbed and to prevent cavitation occurring, the pump-NPSHR, positive suction head and water temperature must be kept under control.

Cavitation and/or compression of gases lead to uncontrollable pressure-kicks which can ruin pump and unit parts and also be dangerous to the operator or anyone standing nearby.

Giant Plunger Pumps are suitable for pumping clean water and other non-aggressive or abrasive media with a specific weight similar to water.

Before pumping other liquids, such as inflammable, explosive and toxic media, the pump manufacturer must under all circumstances be consulted with regard to the resistance of the pump material. It is the responsibility of the equipment manufacturer and/or operator to ensure that all pertinent safety regulations are adhered to.

Additional Instructions for P46HT (high temperature) pumps

 Please read operating instructions carefully before putting the pump into operation!

Important! Do **not** use grease when renewing the high pressure plunger seals (pos. 31/50).

Hot water causes grease to wash off the seal which in turn can jam valves! The new seals should only be oiled lightly before installation.

Specifications

Model P46W/P46W-HK

	<u>U.S.</u>	<u>Metric</u>
Maximum Flow.....	3.9 GPM.....	14.7 L/min
Discharge Pressure	2200 PSI.....	150 bar
Inlet Pressure.....	-4.35 to 145 PSI.....	-0.3 to 10 bar
Power Consumption	6.0 BHP.....	4.5 kW
Maximum Crankshaft Rotation Speed		1420 RPM
Stroke	0.56".....	14.1mm
Crankcase Oil Capacity	8.8 fl.oz.	0.26 Liters
Temperature of Pumped Fluids (P46W)	Up to 160 °F	70 °C
Temperature of Pumped Fluids (P46-HK).....	Up to 195 °F.....	90 °C
Plunger Diameter.....	0.71".....	18mm
Inlet Ports.....		(2) 1/2" BSP
Discharge Ports		(2) 3/8" BSP
Pulley Mounting		Either Side
Shaft Rotation	Top of pulley towards head	
Weight.....	13.9 lbs	6.3 kg
Crankshaft Diameter.....	0.71".....	18mm
Volumetric Efficiency @ 1420RPM		0.96
Mechanical Efficiency @ 1420RPM.....		0.80
NPSHR (P46W).....	17.4 Ft. head.....	5.3 mWs

Consult the factory for special requirements that must be met if the pump is to operate beyond one or more of the limits specified above.

PULLEY INFORMATION

Pulley selection and pump speed are based on a 1725 RPM motor and "B" section belts. When selecting desired GPM, allow for a ±5% tolerance on pumps output due to variations in pulleys, belts and motors among manufacturers.

1. Select GPM required, then select appropriate motor and pump pulley from the same line.
2. The desired pressure is achieved by selecting the correct nozzle size that corresponds with the pump GPM.

HORSEPOWER INFORMATION

The ratings shown in the chart reflect the horsepower requirements for electric motors. We recommend motors with a 1.15 service factor be specified.

To compute specific pump horsepower requirements, use the following formula:

$$(GPM \times PSI) / 1450 = HP$$

P46W / P46W-HK Horsepower Requirements					
RPM	GPM	1000 PSI	1500 PSI	1700 PSI	2200 PSI
745	2.0	1.4	2.1	2.3	3.0
910	2.5	1.7	2.6	2.9	3.8
1140	3.1	2.1	3.2	3.6	4.7
1305	3.6	2.5	3.7	4.2	5.5
1420	3.9	2.7	4.0	4.5	5.9

Model P46HT Specifications

	<u>U.S.</u>	<u>Metric</u>
Maximum Flow	2.5 GPM	9.3 L/M
Discharge Pressure	870 PSI	60 bar
Inlet Pressure	-4.35 to 145 PSI	-0.3 to 10 bar
Maximum Crankshaft Rotation Speed		900 RPM
Power Consumption	0.94 BHP	0.7 kW
Stroke	0.56"	14.1mm
Plunger Diameter	0.71"	18mm
Crankcase Capacity	8.8 fl. oz.	0.26 Liters
Temperature	Up to 221°F	105° C
Inlet Ports		(2) 1/2" BSP
Discharge Ports		(2) 3/8" BSP
Pulley Mounting		Either Side
Shaft Rotation		Top of pulley towards head
Weight	13.9 lbs.	6.3kg
Crankshaft Diameter	0.71"	18mm
NPSHR	14.8 ft.-head	4.5 mWs

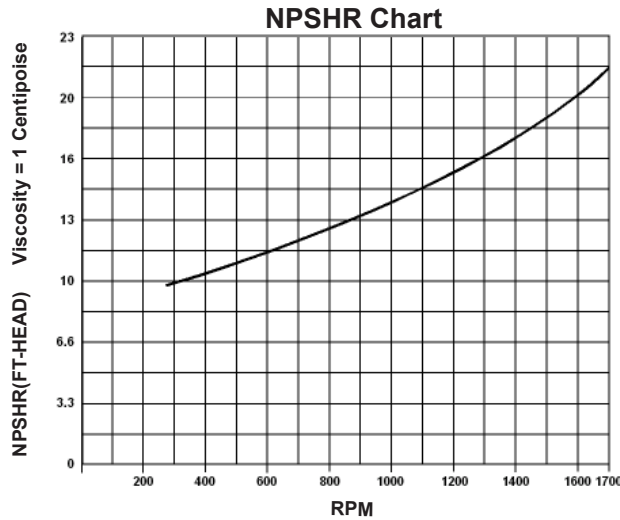

Consult the factory for special requirements that must be met if the pump is to operate beyond one or more of the limits specified above.

PULLEY INFORMATION

Pulley selection and pump speed are based on a 1725 RPM motor and "B" section belts. When selecting desired GPM, allow for a ±5% tolerance on pumps output due to variations in pulleys, belts and motors among manufacturers.

1. Select GPM required, then select appropriate motor and pump pulley from the same line.
2. The desired pressure is achieved by selecting the correct nozzle size that corresponds with the pump GPM.

HORSEPOWER INFORMATION

The ratings shown in the chart reflect the horsepower requirements for electric motors. We recommend motors with a 1.15 service factor be specified.

To compute specific pump horsepower requirements, use the following formula:

$$(GPM \times PSI) / 1450 = HP$$

P46HT Horsepower Requirements						
RPM	GPM	GPH	200 PSI	400 PSI	600 PSI	900 PSI
385	1.05	62.9	0.14	0.29	0.43	0.65
676	1.8	110.6	0.25	0.50	0.74	1.12
900	2.5	147.3	0.34	0.69	1.03	1.55

Specifications

Model P49W/P49W-HK

	<u>U.S.</u>	<u>Metric</u>
Maximum Flow.....	2.7 GPM.....	10.2 L/M
Discharge Pressure	2200 PSI	150 bar
Inlet Pressure.....	-4.35 to 145 PSI.....	-0.3 to 10 bar
Maximum Crankshaft Rotation Speed		1420 RPM
Stroke	0.41"	10.0 mm
Crankcase Oil Capacity	8.8 fl.oz.	0.26 Liters
Temperature of Pumped Fluids (P49W)	Up to 160 °F	70 °C
Temperature of Pumped Fluids (P49W-HK)	Up to 195 °F.....	90 °C
Plunger Diameter.....	0.71"	18mm
Inlet Ports.....		(2) 1/2" BSP
Discharge Ports		(2) 3/8" BSP
Pulley Mounting		Either Side
Shaft Rotation		Top of pulley towards head
Weight.....	13.9 lbs	6.3 kg
Crankshaft Diameter.....	0.71"	18mm
Volumetric Efficiency @ 1420RPM		0.96
Mechanical Efficiency @ 1420RPM.....		0.80
NPSHR	19.0 ft.-head.....	5.8 mWs

Consult the factory for special requirements that must be met if the pump is to operate beyond one or more of the limits specified above.

PULLEY INFORMATION

Pulley selection and pump speed are based on a 1725 RPM motor and "B" section belts. When selecting desired GPM, allow for a ±5% tolerance on pumps output due to variations in pulleys, belts and motors among manufacturers.

1. Select GPM required, then select appropriate motor and pump pulley from the same line.
2. The desired pressure is achieved by selecting the correct nozzle size that corresponds with the pump GPM.

HORSEPOWER INFORMATION

The ratings shown in the chart reflect the horsepower requirements for electric motors. We recommend motors with a 1.15 service factor be specified.

To compute specific pump horsepower requirements, use the following formula:

$$(GPM \times PSI) / 1450 = HP$$

P49W/P49W-HK Horsepower Requirements					
RPM	GPM	1000 PSI	1500 PSI	1700 PSI	2200 PSI
745	1.4	0.97	1.5	1.6	2.1
910	1.7	1.2	1.8	2.0	2.6
1140	2.2	1.5	2.3	2.6	3.3
1305	2.5	1.7	2.6	2.9	3.8
1420	2.7	1.9	2.8	3.2	4.1

Exploded View and Parts List - P46W, P46W-HK, P46HT, P49W & P49W-HK

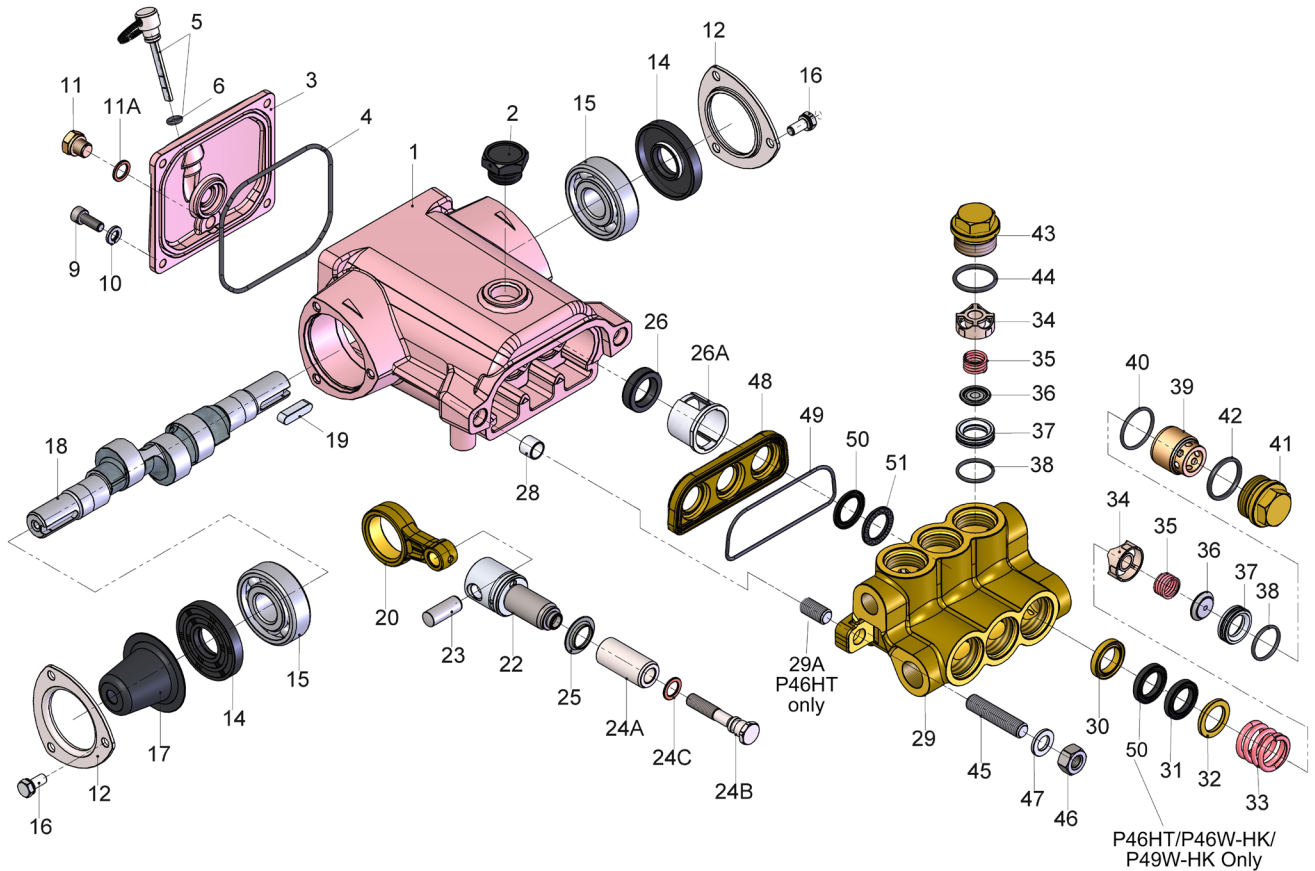

ITEM	PART	DESCRIPTION	QTY.	ITEM	PART	DESCRIPTION	QTY.
1	07222	Crankcase	1	30	07230	Pressure Ring	3
2	07181	Vent/Filter Plug with Seal	1	31	07241	V-Sleeve (P46W/P49W)	3
3	08004	Cover, Crankcase	1	31	11511	V-Sleeve, High Temp. (P46W-HK, P46HT, P49W-HK)	3
4	08005	O-Ring	1	32	07231	Support Ring	3
5	08008	Oil Dipstick Assembly	1	33	07232	Pressure Spring	3
6	01009	O-Ring	1	34	07325	Retainer, Spring	6
9	07188	Cylinder Screw with Slot	4	34	05593	Retainer, Spring (P46HT)	6
10	07223-0100	Spring Washer	4	35	06017-0100	Valve Spring	6
11	08012	Oil Drain Plug	1	36	06016	Valve Plate	6
11A	06709	Gasket, Oil Drain Plug	1	37	06014	Valve Seat	6
12	07224	Bearing Cover	2	38	06015	O-Ring	6
14	08015	Radial Shaft Seal	2	39	07233	Suction Valve Adaptor	3
15	08020	Ball Bearing	2	40	07234	O-Ring, Adapter	3
16	07225	Screw and Washer	6	41	07235	Plug, Manifold (Inlet)	3
17	07226	Shaft Protector	1	42	12004	O-Ring, for Item 41	3
18	07227	Crankshaft (P46)	1	43	07792	Plug, Manifold (Discharge)	3
18	04293	Crankshaft (P49)	1	44	07035	O-Ring for Item 43	3
19	03385	Fitting Key	1	45	07215	Stud, Manifold	2
20	08024	Connecting Rod	3	46	08040	Hex Nut, Manifold Stud	2
22	07201	Crosshead Assembly	3	47	08041	Spring Washer, Stud	2
23	01031	Crosshead Pin	3	48	07237	Housing, Rear V-Sleeve	1
24A	07021	Plunger Pipe	3	49	07238	O-Ring, Rear V-Sleeve	1
24B	08456	Tension Screw	3	50	07239	Rear V-Sleeve (P46W/P49W)	3
24C	07676	Copper Ring	3	50	11512	High Temperature Seal (P46W-HK, P46HT, P49W-HK)	6
25	06648	Flinger	3	51	07240	Support Ring	3
26	07206	Radial Shaft Seal	3				
26A	11510	Spacer Sleeve	3				
28	07207	Shim, Manifold Stud	2				
29	07033-NPT	Manifold	1				
29A	11502	Stud Bolt (P46HT only)	2				

P46W, P46W-HK, P46HT, P49W & P49W-HK REPAIR KITS

Complete Plunger Packing Kit P46W & P49W #09081

Item	Part #	Description	Qty.
31	07241	V-Sleeve	3
40	07234	O-Ring	3
50	07239	Rear V-Sleeve	3
51	07240	Support Ring	3

Plunger Packing Kit P46W-HK, P46HT & P49W-HK #09514

Item	Part #	Description	Qty.
31	11511	Sleeve	3
40	07234	O-Ring, Adapter	3
42	12004	O-Ring, Plug	3
49	07238	O-Ring, Rear V-Sleeve	1
50	11512	High Temp. Rear Seal	6
51	07240	Support Ring	3

Oil Seal Kit #09202

Item	Part #	Description	Qty.
26	07206	Radial Shaft Seal	3

Valve Assembly Kit P46W, P46W-HK, P49W & P46W-HK #09039

Item	Part #	Description	Qty.
34	07325	Spring Retainer	6
35	06017-0100	Valve Spring	6
36	06016	Valve Plate	6
37	06014	Valve Seat	6
38	06015	O-Ring, Valve Seat	6
40	07234	O-Ring, Adapter	3
42	12004	O-Ring, Inlet Plug	3
44	07035	O-Ring, Discharge Plug	3

Valve Assembly Kit, P46HT #09497

Item	Part #	Description	Qty.
34	05593	Spring Retainer	6
35	06017-0100	Valve Spring	6
36	06016	Valve Plate	6
37	06014	Valve Seat	6
38	06015	O-Ring	6
40	07234	O-Ring, Adaptor	3
42	12004	O-Ring, Inlet Plug	3
44	07035	O-Ring, Discharge Plug	3

P46W, P46W-HK, P46HT, P49W & P49W-HK TORQUE SPECIFICATIONS

Position	Item#	Description	Lubrication Info	Torque Amount
9	07188	Cylinder Screw with Slot		88 in.-lbs. (10 Nm)
11	08012	Oil Drain Plug with Seal		132 in.-lbs. (15 Nm)
16	07225	Screw and Washer		88 in.-lbs. (10 Nm)
24B	08456	Tension Screw, Plunger	Loctite 243	200 in.-lbs. (22.5 Nm)
24C	07676	Copper Ring	Loctite 243	
41	07235	Plug, Manifold (Inlet)		51 ft.-lbs. (70 Nm)
43	07034	Plug, Manifold (Outlet)	Loctite 243	51 ft.-lbs. (70 Nm)
46	08040	Hexagon Nut, Manifold Stud		35 ft.-lbs. (47.5 Nm)

Pump Mounting Selection Guide

<p>Bushings 01065 - 18 mm Tapered H Bushing</p>	<p>Rails 01034 - Steel Box Rails (L=9.25" x W=1.18" x H=1.62") 01075 - Plated Steel Channel Rails (L=9.00" x W=2.12" x H=2.50")</p>
<p>Pulley & Sheaves 01061 - 7.75" Cast Iron 1 gr. - AB Section 01062 - 7.75" Cast Iron - 2 gr. - AB Section 01066 - 18 mm - 8" Steel Pulley - 1 gr.</p>	

PUMP SYSTEM MALFUNCTION

<u>MALFUNCTION</u>	<u>CAUSE</u>	<u>REMEDY</u>
The Pressure and/ or the Delivery Drops	Worn packing seals Broken valve spring Belt slippage Worn or Damaged nozzle Fouled discharge valve Fouled inlet strainer Worn or Damaged hose Worn or Plugged relief valve on pump Cavitation Unloader	Replace packing seals Replace spring Tighten or Replace belt Replace nozzle Clean valve assembly Clean strainer Repair/Replace hose Clean, Reset, and Replace worn parts Check suction lines on inlet of pump for restrictions Check for proper operation
Water in crankcase	High humidity Worn seals	Reduce oil change interval Replace seals
Noisy Operation	Worn bearings Cavitation	Replace bearings, Refill crankcase oil with recommended lubricant Check inlet lines for restrictions and/or proper sizing
Rough/Pulsating Operation with Pressure Drop	Worn packing Inlet restriction Accumulator pressure Unloader Cavitation	Replace packing Check system for stoppage, air leaks, correctly sized inlet plumbing to pump Recharge/Replace accumulator Check for proper operation Check inlet lines for restrictions and/or proper size
Pressure Drop at Gun	Restricted discharge plumbing	Re-size discharge plumbing to flow rate of pump
Excessive Leakage	Worn plungers Worn packing/seals Excessive vacuum Cracked plungers Inlet pressure too high	Replace plungers Adjust or Replace packing seals Reduce suction vacuum Replace plungers Reduce inlet pressure
High Crankcase Temperature	Wrong Grade of oil Improper amount of oil in crankcase	Giant oil is recommended Adjust oil level to proper amount

Preventative Maintenance Check List & Recommended Spare Parts List						
Check	Daily	Weekly	50 hrs	Every 500 hrs	Every 1500 hrs	Every 3000 hrs
Oil Level/Quality	X					
Oil Leaks	X					
Water Leaks	X					
Belts, Pulley		X				
Plumbing		X				
Recommended Spare Parts						
Oil Change (8 oz.) p/n 01154			X	X		
Plunger Packing Kits (1 kit/pump) (see page 7 for kit list)					X	
Valve Assembly Kit (1 kit/pump) (see page 7 for kit list)					X	
Oil Seal Kit (1 kit/pump) (see page 7 for kit list)						X

REPAIR INSTRUCTIONS - P46W, P46W-HK, P46HT, P49W & P49W-HK



1. With a 22mm socket, remove the three discharge (43) and three inlet (41) manifold plugs. Check o-rings (42 & 44) for wear and replace as necessary.

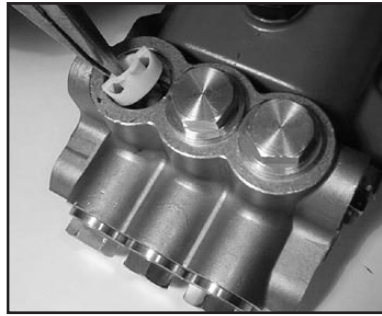

2. Remove the discharge spring retainer (34), valve spring (35), and valve plate (36).



3. Use a small slide hammer to remove valve seats (37) from manifold (29). Inspect valve plates (36) and valve seats (37) for wear. If excessive pitting is seen, replace the worn parts. Check valve seat o-ring (38) for wear and replace as necessary.

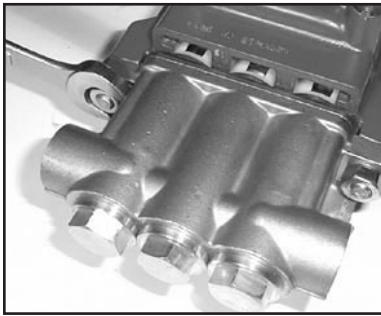

4. Drain the oil from the pump. Turn the pump over to remove the two manifold stud nuts (46) with a 17mm wrench.

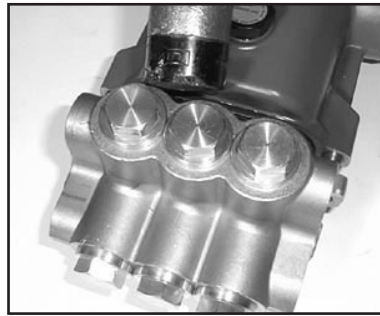

5. Tap the back of the manifold (29) with a rubber mallet to dislodge, and slide off the pump.



6. From the front inlet valve ports, remove the inlet valve assembly (34-40).

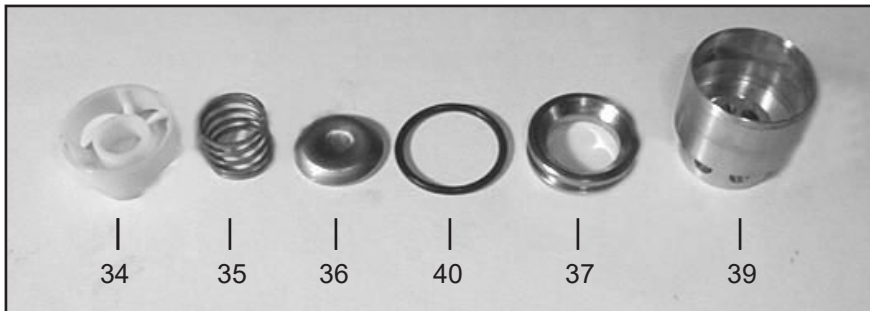

7. Inspect and clean the valve assembly parts. If pitted or worn, replace inlet valve seats (37), valve plates (36), spring (35) and spring retainers (34). Reinsert items 34-38 into valve adapter (39).

NOTE: Contact Giant Industries for Service School Information. Phone: (419)-531-4600

REPAIR INSTRUCTIONS - P46W, P46W-HK, P46HT, P49W & P49W-HK

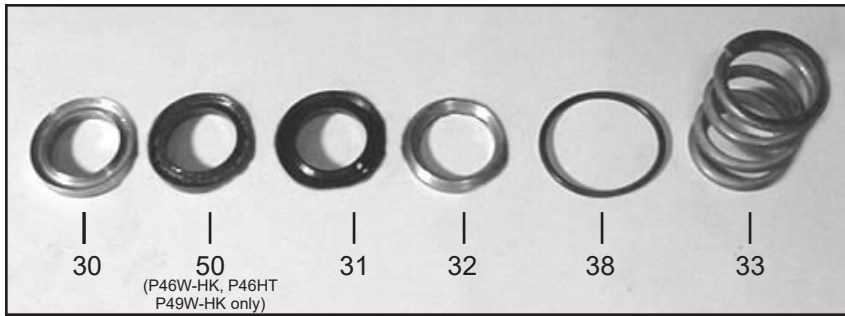

8. The pressure rings (item 30) can now be removed by pulling straight out. Inspect and clean manifold (29) and pressure ring. Replace if necessary. From the front of the pump reinstall pressure rings into manifold (29) with grooved side towards front of manifold. Install new v-sleeves (31), with grooved sides towards front of pump. For P46W-HK, P46HT & P49W-HK pumps, install high temperature seal (50) before v-sleeve (31) with grooved sides towards front of pump. Replace the support rings (32) and pressure springs (33) into manifold (29). Install valve assembly (34-40) into manifold (29). Reinstall manifold plugs (43) and torque plugs to 51 ft.-lbs. (70 Nm).

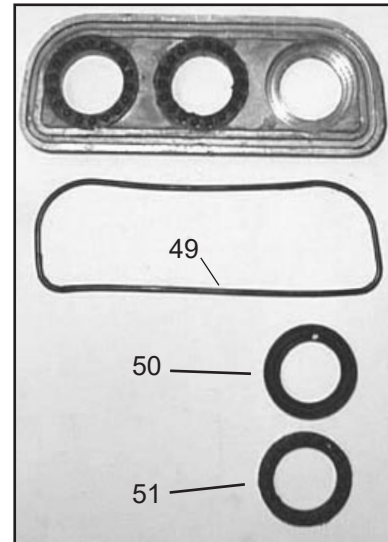

9. The rear V-sleeve housing (48) may be removed by prying evenly outward with a flat screwdriver. After slipping housing over plunger, inspect rear v-sleeves (50), support rings (51) and O-ring (49) and replace as necessary.

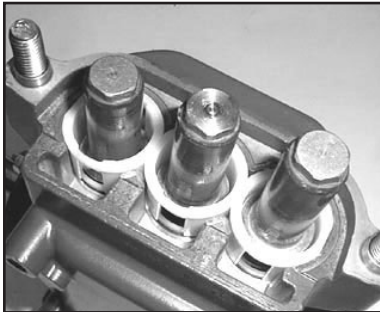

10. Inspect ceramic plunger (24A) tips for wear. If necessary, replacement of the ceramic plungers may be accomplished by removing the plunger bolt assemblies (24B and 24C) with a 13mm wrench. Ceramic plungers should now slide off the stainless steel plunger base (22). Excessive resistance to plunger removal may be overcome by heating the stainless steel plunger base. This will melt any excess loc-tite beneath the ceramic plunger allowing easy removal.

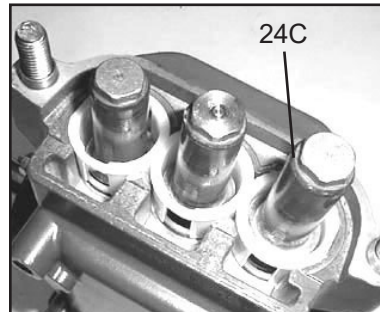

11. Replace copper ring (24C) onto plunger bolt (24B). Slide plunger bolt assembly into ceramic plunger (24A). Apply a light film of loc-tite to plunger bolt threads and place plunger assembly onto stainless steel plunger base (22) and tighten to 200 in.-lbs. (22.5 Nm).

12. To replace plunger oil seals (26), proceed to "Gear End Disassembly" section below. Otherwise, continue as described below.



13. Before replacing pump manifold (29), first rotate crankshaft (18) until two outside plungers (24A) extend evenly forward. Next lubricate rear v-sleeves (50) and support ring (51) in the rear v-sleeve housing (48) and slide housing over plungers. Lubricate ceramic plungers with a light film of oil. Carefully and evenly slide manifold over plungers and press manifold firmly against crankcase (1). Replace manifold stud bolts (45), washers (47) and nut (46) and tighten to 35 ft.-lbs. (47.5 Nm).

NOTE: Contact Giant Industries for Service School Information. Phone: (419)-531-4600

REPAIR INSTRUCTIONS - P46W, P46W-HK, P46HT, P49W & P49W-HK

Gear End Disassembly

14. Remove the crankcase cover bolts (9). Inspect the crankcase cover O-ring (4) for wear. Replace if necessary.
15. Inspect the dip stick (5) vent hole for signs of clogging. Clean if necessary.
16. To remove the crankshaft (18), first remove the bearing cover plates (12) Remove the key (19).
17. Hold the pump rear assembly with a wooden fixture, or other suitable device, in order to secure it while removing the crankshaft (18). Using a plastic mallet, tap the crankshaft (18) from one side while turning it from the other side. The turning insures that during this sequence the crankshaft does not become wedged against the connecting rods (20). The far side bearing (15) will remain in the crankcase (1). When free, the crankshaft (18) can be removed by hand.
18. The crankshaft bearing (15) remains on the crankshaft (18) as it is removed. The near side crankshaft seal (14) will be removed by this procedure.
19. If necessary, use a bearing puller to remove crankshaft bearing (15).
20. Remove the connecting rod (20) and plunger rod/crosshead assembly (22) from the rear of the pump by pulling straight out of the crosshead guides.
21. To remove the crankcase oil seal (26), tap oil seal out from the rear of the crankcase using a dowel and rubber mallet. The area onto which the oil seal rests should be clean and dry. Put a small drop of loc-tite on the oil seals and place into crankcase with clips facing the rear of the pump.
22. To remove the crosshead pin (23) from the crosshead (22), the assembly should be positioned on a wooden fixture to avoid damage to crosshead. Drive out pin (23) on opposite side of mark on the crosshead. On those pumps without mark on crosshead, drive out pin by tapping on tapered side of pin.
23. To remove the bearing remaining in the crankcase, insert small end of Giant Bearing tool and tap with a rubber mallet untill bearing and seal are completely removed. The bearing can only be removed from the inside by inserting the Giant Bearing Tool through the opposite side of the crankcase (1) and should be inspected for possible damage.

Gear End Reassembly

24. To reassemble, place the far bearing in the crankcase bearing housing and with the Giant Bearing tool as a driver, tap into the crankcase (1) using a rubber mallet.
25. Insert the far side crankshaft oil seal (14) with the Giant Bearing Tool making sure it is firmly seated and well oiled. Always make sure that the crankshaft seal (14) lip does not show signs of wear. Replace the bearing cover (12) and tighten securely.
26. Replace the connecting rod (20) and plunger rod/crosshead assembly (22) by press-fitting the crosshead pin (23). Make sure to insert the beveled edge of the crosshead pin into crosshead. If the crosshead has a mark, install pin from marked side. The crosshead pin (23) should not extend beyond either side of the crosshead in order to prevent damage to the crosshead bore of the crankcase.
27. Place each crosshead/plunger assembly (22) into the pump making sure that all of the parts are well oiled before insertion into the crankcase.
28. Replace near side bearing on crankshaft (18) and use mallet to tap into place.
29. Take the crankshaft (18) end with the bearing and insert the other end through the bearing housing carefully threading the lobes of the crankshaft through the well lubricated connecting rods (20). Turning the crankshaft while tapping it through the connecting rods will help prevent binding and possible damage to the connecting rods. Continue tapping the crankshaft through the connecting rods (20) until it is firmly seated into far side bearing.
30. Insert the near side crankshaft oil seal (14), making sure it is firmly seated and well oiled. Replace the bearing cover (12) and tighten securely.
31. See instructions (13 above) for re-installing fluid end onto gear end.
32. Clean the back edge of crankcase and replace the crankcase cover. Be careful not to pinch the crankcase cover O-ring.
33. Fill the pump crankcase with 8.8 oz. (0.26L) of Giant oil. and check the oil level with the dipstick. Proper level is center of two lines Reinstall the pump into your system.

P46W, P46W-HK, P46HT, P49W & P49W-HK DIMENSIONS - Inches (mm)

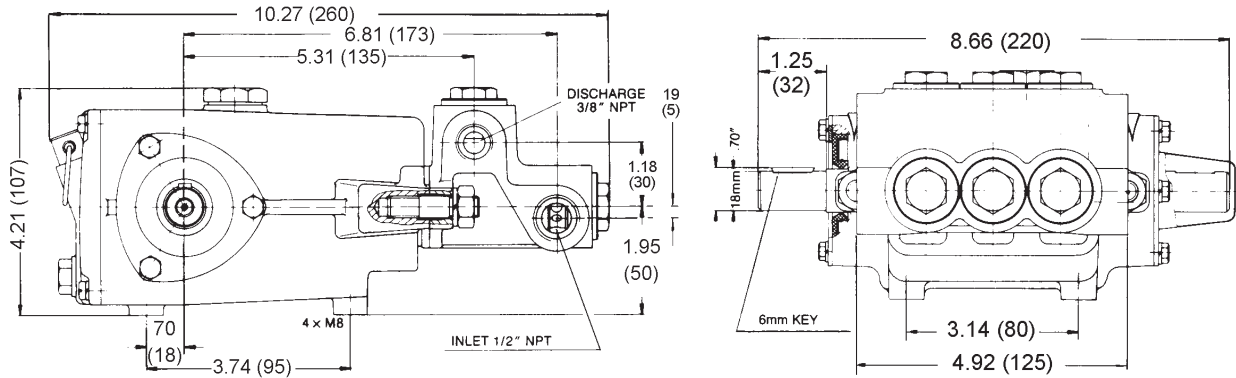

GIANT INDUSTRIES LIMITED WARRANTY

Giant Industries, Inc. pumps and accessories are warranted by the manufacturer to be free from defects in workmanship and material as follows:

1. Five (5) years from the date of shipment for all pumps used in portable pressure washers with NON-SALINE, clean water applications.
2. Two (2) years from the date of shipment for Giant pumps used in car wash applications.
3. One (1) year from the date of shipment for all other Giant industrial and consumer pumps.
4. Six (6) months from the date of shipment for all rebuilt pumps
5. Ninety (90) days from the date of shipment for all Giant accessories.

This warranty is limited to repair or replacement of pumps and accessories of which the manufacturer's evaluation shows were defective at the time of shipment by the manufacturer. The following items are NOT covered or will void the warranty:

1. Defects caused by negligence or fault of the buyer or third party.
2. Normal wear and tear to standard wear parts.
3. Use of repair parts other than those manufactured or authorized by Giant.
4. Improper use of the product as a component part.
5. Changes or modifications made by the customer or third party.
6. The operation of pumps and or accessories exceeding the specifications set forth in the Operations Manuals provided by Giant Industries, Inc.

Liability under this warranty is on all non-wear parts and limited to the replacement or repair of those products returned prepaid to Giant Industries which are deemed to be defective due to workmanship or failure of material. A Returned Goods Authorization (R.G.A.) number and completed warranty evaluation form is required prior to the return to Giant Industries of all products under warranty consideration. Call (419)-531-4600 or fax (419)-531-6836 to obtain an R.G.A. number.

Repair or replacement of defective products as provided is the sole and exclusive remedy provided hereunder and the MANUFACTURER SHALL NOT BE LIABLE FOR FURTHER LOSS, DAMAGES, OR EXPENSES, INCLUDING INCIDENTAL AND CONSEQUENTIAL DAMAGES DIRECTLY OR INDIRECTLY ARISING FROM THE SALE OR USE OF THIS PRODUCT.

THE LIMITED WARRANTY SET FORTH HEREIN IS IN LIEU OF ALL OTHER WARRANTIES OR REPRESENTATION, EXPRESS OR IMPLIED, INCLUDING WITHOUT LIMITATION ANY WARRANTIES OR MERCHANTABILITY OR FITNESS FOR A PARTICULAR PURPOSE AND ALL SUCH WARRANTIES ARE HEREBY DISCLAIMED AND EXCLUDED BY THE MANUFACTURER.



WARNING: This product might contain a chemical known to the State of California to cause cancer, and birth defects or other reproductive harm.

For more information go to www.P65Warnings.ca.gov

GIANT
Performance Under Pressure

Giant Industries, Inc.
900 N. Westwood Ave.
Toledo, OH 43607
419-531-4600
419-531-6836 Fax
www.giantpumps.com
© 2022 Giant Industries, Inc.