

# P400 Series -

Triplex Ceramic  
Plunger Pump  
Operating Instructions/  
Repair and Service Manual

## 22 and 25mm Versions

---

For Models:

P420

P420-0011

P420-0021

P422

P423

P425

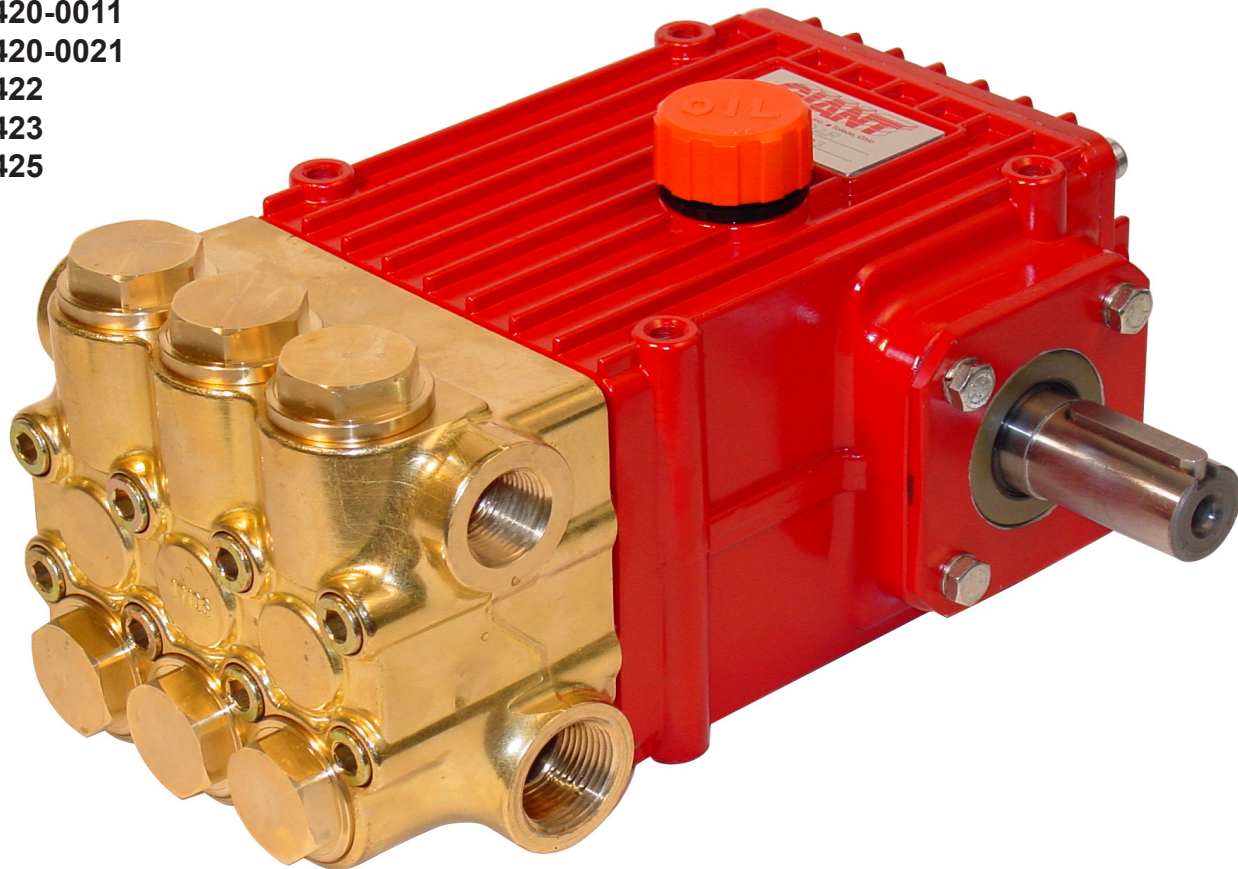

---

**GIANT**  
Performance Under Pressure

**Contents:**

Installation Instructions:	page 2
Pump Specifications (except P425):	pages 3-5
Exploded View:	page 6
Parts List/Kits:	page 7
Pump Specifications (P425):	page 8
Repair Instructions/Torque Specs.:	pages 9-10
Trouble Shooting Chart:	page 11
Recommended Spare Parts List:	page 11
Dimensions:	back page
Warranty Information:	back page

Updated 02/26

# INSTALLATION INSTRUCTIONS

Required NPSH refers to water (specific weight 1kg/dm<sup>3</sup>) at maximum permissible pump revolutions.

## Operation and Maintenance

Check oil level prior to starting to ensure trouble-free water supply.

**Important!** If there is a **danger of frost**, the water in the pump and in the pump fittings (particularly the unloader valve) must be emptied. The second discharge port can also be used and the pump run "dry" for 1-2 minutes for this purpose.

Oil amount: 30.4 ounces (0.9 liters). Only use **ISO VG 220 industrial gear oil** (e.g. Aral Degol BG220) or **automobile gear oil SAE 90 GL4** (Giant p/n 01154).

Initial oil change after 50 operating hours and then every 500 hours, after 1 year if used less. Caution when operating in damp places or with high temperature fluctuations. Oil must be changed immediately should condensate (frothy oil) occur in the gear box.

### NPSH values must be observed.

Maximum input pressure 145 PSI (10 bar), maximum suction head -4.35 PSI (-0.3 bar). Make sure that suction pulsation is sufficiently dampened - water column resonance must be avoided.

**Important!** If the pump is not used for a long period of time, it is possible the seals (23/23B) could become hard or brittle thus causing the pump to leak when put into operation.

If this is the case, we recommend these seals be replaced every 4 years.

### Safety Rules

A safety valve is to be installed in accordance with the guidelines for liquid spraying units so that the admissible operating pressure cannot be exceeded by more than 10%. Pump operation without a safety valve as well as any excess in temperature or speed limits automatically voids the warranty.

When the pump is in operation, the drive shaft end and the coupling must be enclosed by a protective cover or a coupling bell.

Pressure in the discharge line and pump must be at zero before any maintenance to the pump takes place. Shut off suction line. Disconnect fuses to ensure that the driving motor does not get switched on accidentally. Make sure that all parts on the pressure side of the unit are vented before starting the pump. In order to prevent air, or an air-water mixture being absorbed and to prevent cavitation occurring, the pump NPSHR (=suction head) and water temperature must be respected.

**Cavitation and/or compression of gases lead to uncontrollable pressure kicks which can ruin pump and unit parts and also be dangerous to the operator or anyone standing nearby.**

Giant Plunger Pumps are suitable for pumping clean water and other non-aggressive or non-abrasive media with a specific weight similar to water.

**Before pumping other liquids - especially inflammable, explosive and toxic media - the pump manufacturer must be consulted with regard to the resistance of the pump material. It is the responsibility of the equipment manufacturer and/or operator to ensure that all pertinent safety regulations are adhered to.**

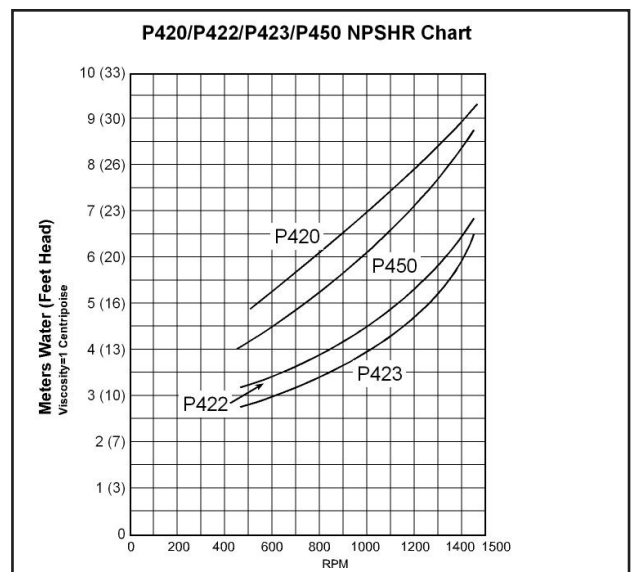

# Specifications

## Models P420A, P420A-0011, P420A-0021

	U.S.	(Metric)
Volume .....	Up to 12.8 GPM .....	(48.4 L/min)
Discharge Pressure .....	Up to 2175 PSI .....	(150 bar)
Maximum Power Consumption .....	19.2 BHP .....	(14.3 kW)
Inlet Pressure .....	-4.35 to 145 PSI .....	(-.3 to 10 bar)
Stroke .....	0.945" .....	(24mm)
RPM .....	Up to 1450 RPM	
Plunger Diameter .....	0.98" .....	(25mm)
Temperature of Pumped Fluids .....	Up to 160 °F .....	(70 °C)
Inlet Ports .....		(2) 1" NPT
Discharge Ports .....		(2) 3/4" NPT
Shaft Rotation .....	Top of pulley towards fluid end	
Crankshaft Diameter .....	1.1" .....	(28mm)
Key Width .....	0.315" .....	(8mm)
Shaft Mounting .....	Either side <sup>1</sup>	
Weight .....	38.3 lbs. ....	(17.4 kg)
Crankcase Capacity .....	30.4 fl.oz. ....	(0.9 liters)
Volumetric Efficiency @ 1450 .....	(0.95)	
Mechanical Efficiency @ 1450 .....	(0.86)	
NPSHR .....	30.5 foot of Head .....	(9.3 meters of Head)

Consult the factory for special requirements that must be met if the pump is to operate beyond one or more of the limits specified above.

**NOTES:**

In order to drive the pump from the side opposite the present shaft extension, simply remove the valve casing from the crankcase and rotate the pumps 180 degrees to the desired position. Be certain to rotate the seal case (item #20) as well, so that the weep holes are down at the six o'clock position. Exchange the oil fill and the oil drain plugs, also. Refer to the repair instructions as necessary for the proper assembly sequence.

<b>P420 HORSEPOWER REQUIREMENTS</b>					
RPM	GPM	1000 PSI	1500 PSI	1700 PSI	2175 PSI
785	6.9	4.8	7.1	8.1	10.4
900	7.9	5.4	8.2	9.3	11.9
1010	8.9	6.1	9.2	10.4	13.4
1120	9.9	6.8	10.2	11.6	14.9
1240	10.9	7.5	11.3	12.8	16.4
1450	12.8	8.8	13.2	15.0	19.2

**HORSEPOWER RATINGS:**

The rating shown are the power requirements for the pump. Gas engine power outputs must be approximately twice the pump power requirements shown above.

We recommend a 1.15 service factor be specified when selecting an electric motor as the power source. To compute specific pump horsepower requirements, use the following formula:  

$$HP = (GPM \times PSI) / 1450$$

**SPECIAL NOTE:**  
 The theoretical gallons per revolution (gal/rev) is 0.00883. To find specific outputs at various RPM, use the formula:  $GPM = 0.00883 \times RPM$

# Specifications Model P422

	U.S.	(Metric)
Volume .....	Up to 9.9 GPM .....	(37.3 LPM)
Discharge Pressure (Continuous) .....	Up to 2610 PSI .....	(180 bar)
Discharge Pressure (Intermittent).....	Up to 3000 PSI.....	(200 bar)
Maximum Power Consumption.....	17.7 BHP.....	(13.2 kW)
Inlet Pressure.....	-4.35 to 145 PSI .....	(-.3 to 10 bar)
Stroke .....	0.94" .....	(24mm)
RPM.....	.....	Up to 1450 RPM
Plunger Diameter.....	0.87" .....	(22mm)
Temperature of Pumped Fluids.....	Up to 160 °F .....	(70 °C)
Inlet Ports.....	.....	(2) 1" NPT
Discharge Ports .....	.....	(2) 3/4" NPT
Shaft Rotation .....	Top of pulley towards manifold	
Crankshaft Diameter .....	1.102" .....	(28mm)
Key Width .....	.315" .....	(8mm)
Shaft Mounting.....	Either side <sup>1</sup>	
Weight.....	38.3 lbs.....	(17.4 kg)
Crankcase Capacity.....	30.4 fl.oz. ....	(0.9 liters)
Volumetric Efficiency @ 1450 .....	(0.95)	
Mechanical Efficiency @ 1450.....	(0.83)	
NPSHR .....	22.3 foot of Head.....	(6.8 meters of Head)

Consult the factory for special requirements that must be met if the pump is to operate beyond one or more of the limits specified above.

**NOTES:**

In order to drive the pump from the side opposite the present shaft extension, simply remove the valve casing from the crankcase and rotate the pumps 180 degrees to the desired position. Be certain to rotate the seal case (item #20) as well, so that the weep holes are down at the six o'clock position. Exchange the oil fill and the oil drain plugs, also. Refer to the repair instructions as necessary for the proper assembly sequence.

<b>P422 HORSEPOWER REQUIREMENTS</b>					
RPM	GPM	1000 PSI	1500 PSI	2610 PSI	3000 PSI*
900	6.1	4.2	6.3	11.0	12.6
1050	7.2	5.0	7.5	13.0	14.9
1160	7.9	5.4	8.2	14.2	16.3
1300	8.9	6.1	9.2	16.0	18.4
1450	9.9	6.8	10.2	17.8	20.5

\*Intermittent duty only

**SPECIAL NOTE:**  
The theoretical gallons per revolution (gal/rev) is 0.00683. To find specific outputs at various RPM, use the formula:  $GPM = 0.00683 \times RPM$

**HORSEPOWER RATINGS:**

The rating shown are the power requirements for the pump. Gas engine power outputs must be approximately twice the pump power requirements shown above.

We recommend a 1.15 service factor be specified when selecting an electric motor as the power source.

To compute specific pump horsepower requirements, use the following formula:

$$HP = (GPM \times PSI) / 1450$$

# Specifications Model P423

	U.S.	(Metric)
Volume .....	Up to 8.2 GPM .....	(31.1 LPM)
Discharge Pressure .....	Up to 2900 PSI .....	(200 bar)
Maximum Power Consumption .....	16.4 BHP .....	(12.2 kW)
Inlet Pressure .....	-4.35 to 145 PSI .....	(-.3 to 10 bar)
Stroke .....	0.79" .....	(20mm)
RPM .....		Up to 1450 RPM
Plunger Diameter .....	0.87" .....	(22mm)
Temperature of Pumped Fluids .....	Up to 160 °F .....	(70 °C)
Inlet Ports .....		(2) 1" NPT
Discharge Ports .....		(2) 3/4" NPT
Shaft Rotation .....	Top of pulley towards manifold	
Crankshaft Diameter .....	1.102" .....	(28mm)
Key Width .....	.315" .....	(8mm)
Shaft Mounting .....	Either side <sup>1</sup>	
Weight .....	38.3 lbs. ....	(17.4 kg)
Crankcase Capacity .....	30.4 fl.oz. ....	(0.9 liters)
Volumetric Efficiency @ 1450 .....		(0.95)
Mechanical Efficiency @ 1450 .....		(0.83)
NPSHR .....	21.0 foot of Head..... (6.4 meters of Head)	

Consult the factory for special requirements that must be met if the pump is to operate beyond one or more of the limits specified above.

**NOTES:**

In order to drive the pump from the side opposite the present shaft extension, simply remove the valve casing from the crankcase and rotate the pumps 180 degrees to the desired position. Be certain to rotate the seal case (item #20) as well, so that the weep holes are down at the six o'clock position. Exchange the oil fill and the oil drain plugs, also. Refer to the repair instructions as necessary for the proper assembly sequence.

<b>P423HORSEPOWER REQUIREMENTS</b>					
RPM	GPM	1000 PSI	1500 PSI	2000 PSI	2900 PSI
900	5.1	3.5	5.3	7.0	10.2
1050	5.9	4.1	6.1	8.1	11.8
1160	6.6	4.6	6.8	9.1	13.2
1300	7.4	5.1	7.7	10.2	14.8
1450	8.2	5.7	8.5	11.3	16.4

**SPECIAL NOTE:**

The theoretical gallons per revolution (gal/rev) is 0.00566. To find specific outputs at various RPM, use the formula:  $GPM = 0.00566 \times RPM$

**HORSEPOWER RATINGS:**

The rating shown are the power requirements for the pump. Gas engine power outputs must be approximately twice the pump power requirements shown above.

We recommend a 1.15 service factor be specified when selecting an electric motor as the power source. To compute specific pump horsepower requirements, use the following formula:  
 $HP = (GPM \times PSI) / 1450$

# EXPLODED VIEW - P420 / P420-0011 / P420-0021 / P422 / P423 AND P425 PUMPS

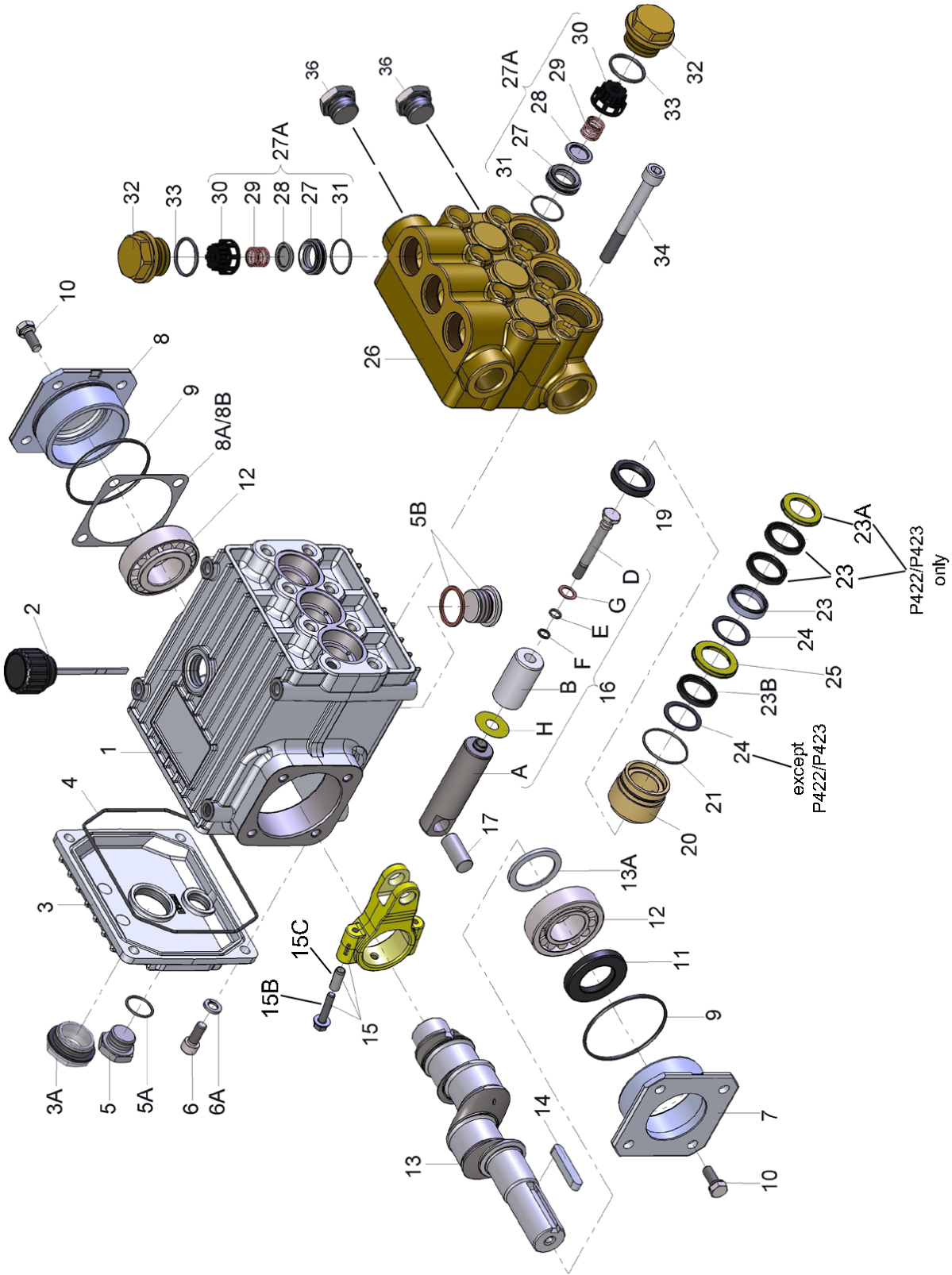

# P420 / P420-0011 / P420-0021 / P422 / P423 and P425 SPARE PARTS LIST

A = P420 B = P422 G = P423 H = P425 J = P420-0011 K = P420-0021

ITEM	PART	DESCRIPTION	QTY.	ITEM	PART	DESCRIPTION	QTY.
1	08377	Crankcase	1	16G	07258	Copper Washer	3
2	08378	Oil Fill Plug with Gasket	1	16H	06431	Oil Scraper	3
3	06479	Crankcase cover	1	17	06790	Crosshead Pin	3
3A	07186	Oil Sight Glass w/ Gasket	1	19	05444	Oil Seal	3
4	08380	O-Ring	1	20	05443	Seal Case (A, H, J & K)	3
5	07109	Oil Drain Plug	1	20	05601	Seal Case (B & G)	3
5A	06015	Gasket for Oil Drain Plug	1	21	07266	O-Ring (A, B, G, & H)	3
5B	08092	Plug with Gasket	1	21	07266-0001	O-Ring, Viton (J & K)	3
6	01010	Screw	4	23	12254	V-Sleeve, 25mm (A & H)	3
6A	01011-0400	Spring Washer	4	23	12254-0010	V-Sleeve, 25mm, Viton, (J)	3
7	04739	Bearing Cover, Open	1	23	12254-0020	V-Sleeve, 25mm, Teflon, (K)	3
8	05291	Bearing Cover, Closed	1	23	06249	V-Sleeve with Support Ring, 22mm (B & G)	3
8A	05292	Shim	1-3				
8B	05293	Shim (May not be present)	1-3	23A	06251	Spacer Ring (B & G)	3
9	01016	O-Ring	2	23B	12255	Weep Seal (A & H)	3
10	07114	Screw with Washer	8	23B	12255-0010	Weep Seal, Viton (J)	3
11	07459	Radial Shaft Seal	1	23B	12255-0020	Weep Seal, Teflon (K)	3
12	05350	Taper Roller Bearing	2	23B	13390	Weep Seal (B & G)	3
13	04741	Crankshaft (A, B, J & K)	1	24	08376	Pressure Ring (A, H, J & K)	6
13	04740	Crankshaft (G & H)	1	24	06252	Pressure Ring (B & G)	3
13A	04742	Spacer Ring	1	25	08394	Weep Return Ring (A, H, J & K)	3
14	08091	Fitting Key	1	25	06254	Weep Return Ring (B & G)	3
15	08390	Connecting Rod Assembly	3	26	08395	Manifold	1
15B	05349	Connecting Rod Screw	6	27A	08408	Valve Assembly (A, B, G & H)	6
15C	05348	Adapter Sleeve	6	27A	08408-0001	Valve Assembly (J & K)	6
16	05351	Plunger Assy., 25mm, (A, H, J & K)		27	08370	Valve Seat	6
		For items 16A-16H	3	28	06791-0100	Valve Plate	6
16	05353	Plunger Assy., 22mm, (B & G)		29	06377-0100	Valve Spring	6
		For items 16A-16H	3	30	08372	Valve Spring Retainer	6
16A	05352	Plunger Base	3	31	07212	O-Ring (A, B, G & H)	6
16B	08398	Plunger Pipe, 25mm (A, H, J & K)	3	31	07212-0001	O-Ring, Viton (J & K)	6
16B	06247	Plunger Pipe, 22mm (B & G)	3	32	08373	Plug	6
16D	08399	Tensioning Screw	3	33	07214	O-Ring (A, B, G & H)	6
16E	07023	O-Ring	3	33	07214-0001	O-Ring, Viton (J & K)	6
16F	07203	Backup Ring	3	34	08396	Cap Screw	8

# P420 / P420-0011 / P420-0021 / P422 / P423 and P425 REPAIR KITS

## Plunger Packing Kits

### P420, P425 - # 09140

Item	Part #	Description	Qty
21	07266	O-Ring	3
23	12254	V-Sleeve	3
23B	12255	Weep Seal	3
24	08376	Pressure Ring	6

## Valve Assembly Kit

### P420, P422, P423, P425 - # 09143

Item	Part #	Description	Qty.
27A	08408	Valve Assembly, Complete	6
33	07214	O-Ring	6

## Plunger Packing Kit

### P422, P423 - # 09295

Item	Part #	Description	Qty
21	07266	O-Ring	3
23	06249	V-Sleeve with Support Ring	3
23B	13390	Weep Seal	3
24	06252	Pressure Ring	3

## Oil Seal Kit

### P400 Series - # 09641

Item	Part #	Description	Qty
19	05444	Oil Seal	3

## Optional Viton Plunger Packing Kit

### P420-0011 - # 09140-0011

Item	Part #	Description	Qty
21	07266-0001	O-Ring, Viton	3
23	12254-0010	V-Sleeve, Viton	3
23B	12255-0010	Weep Seal, Viton	3
24	08376	Pressure Ring	6

## Optional Viton Valve Assembly Kit

### P420, P422, P423, P425 - # 09143-0001

Item	Part #	Description	Qty.
27A	08408-0001	Valve Assembly, Complete	6
33	07214-0001	O-Ring	6

## Optional Teflon Plunger Packing Kit

### P420-0021 - # 09140-0021

Item	Part #	Description	Qty
21	07266-0001	O-Ring, Viton	3
23	12254-0020	V-Sleeve, Teflon	3
23B	12255-0020	Weep Seal, Teflon	3
24	08376	Pressure Ring	6

# Specifications Model P425

	U.S.	(Metric)
Volume .....	Up to 10.7 GPM .....	(40.4 LPM)
Discharge Pressure .....	Up to 2465 PSI .....	(170 bar)
Maximum Power Consumption .....	18.1 BHP .....	(13.5 kW)
Inlet Pressure .....	-4.35 to 145 PSI .....	(-.3 to 10 bar)
Stroke .....	0.787" .....	(20mm)
RPM .....	Up to 1450 RPM	
Plunger Diameter .....	0.98" .....	(25mm)
Temperature of Pumped Fluids .....	Up to 160 °F .....	(70 °C)
Inlet Ports .....		(2) 1" NPT
Discharge Ports .....		(2) 3/4" NPT
Shaft Rotation .....	Top of pulley towards manifold	
Crankshaft Diameter .....	1.102" .....	(28mm)
Key Width .....	315" .....	(8mm)
Shaft Mounting .....	Either side <sup>1</sup>	
Weight .....	38.3 lbs. ....	(17.4 kg)
Crankcase Capacity .....	30.4 fl.oz. ....	(0.9 liters)
Volumetric Efficiency @ 1450 .....		(0.95)
Mechanical Efficiency @ 1450 .....		(0.83)
NPSHR .....	26.2 foot of Head .....	(8.0 meters of Head)

Consult the factory for special requirements that must be met if the pump is to operate beyond one or more of the limits specified above.

**NOTES:**

In order to drive the pump from the side opposite the present shaft extension, simply remove the valve casing from the crankcase and rotate the pumps 180 degrees to the desired position. Be certain to rotate the seal case (item #20) as well, so that the weep holes are down at the six o'clock position. Exchange the oil fill and the oil drain plugs, also. Refer to the repair instructions as necessary for the proper assembly sequence.

<b>P425 HORSEPOWER REQUIREMENTS</b>					
RPM	GPM	1000 PSI	1500 PSI	2000 PSI	2465 PSI
750	5.6	3.8	5.7	7.6	9.4
900	6.7	4.6	6.9	9.1	11.3
1010	7.5	5.2	7.7	10.2	12.7
1120	8.3	5.7	8.6	11.4	14.1
1240	9.2	6.3	9.5	12.6	15.6
1450	10.7	7.4	11.1	14.7	18.2

**HORSEPOWER RATINGS:**

The rating shown are the power requirements for the pump. Gas engine power outputs must be approximately twice the pump power requirements shown above.

We recommend a 1.15 service factor be specified when selecting an electric motor as the power source. To compute specific pump horsepower requirements, use the following formula:  

$$HP = (GPM \times PSI) / 1450$$

**SPECIAL NOTE:**  
 The theoretical gallons per revolution (gal/rev) is 0.00738. To find specific outputs at various RPM, use the formula:  $GPM = 0.00738 \times RPM$

## Repair Instructions P420 / P420-0011 / P420-0021 / P422 / P423 and P425

*Note: Always take time to lubricate all metal and nonmetal parts with a light film of oil before reassembly. This step will ensure proper fit, at the same time protecting the pump nonmetal parts (i.e., the elastomers) from cutting and scoring.*

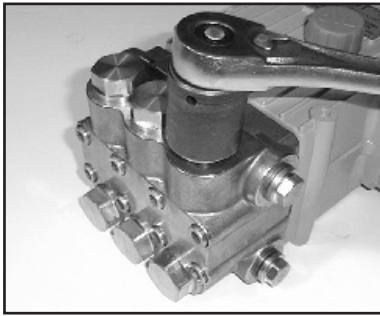

- 1) With a socket wrench, remove the three discharge valve plugs and three inlet valve plugs (32). Inspect the o-ring (33) for wear and replace if damaged.

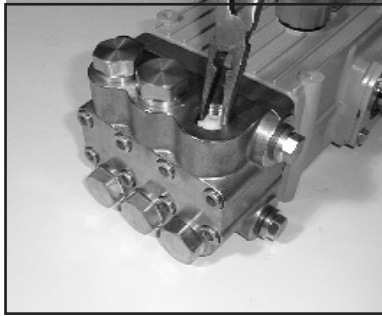

- 2) Using needle nose pliers, remove the inlet and discharge valve assemblies (27A). Note: It may become necessary to remove the valve seat (27) from the valve casing using a slidehammer.

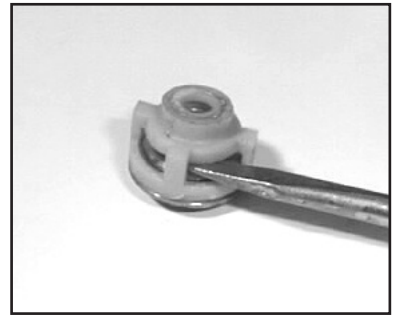

- 3) By inserting a small screw driver between the valve seat (27) and the valve spring retainer (30), the valve assembly can be separated.

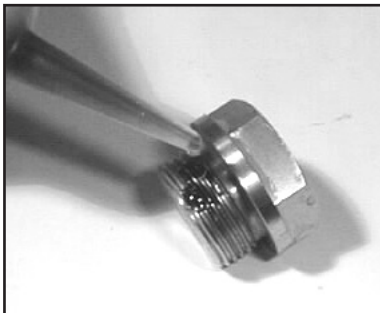

- 4) Remove the o-ring (31). Inspect all parts for wear and replace as necessary. Apply one drop of loctite 243 to the valve plugs (32) and tighten to 107 ft.-lbs. (145 NM).

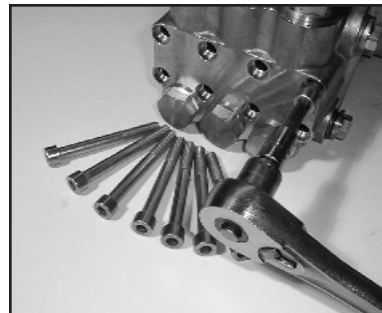

- 5) Use a 8mm allen wrench to remove the 8 socket head cap screws (34). Carefully slide the valve casing (26) out over the plungers.

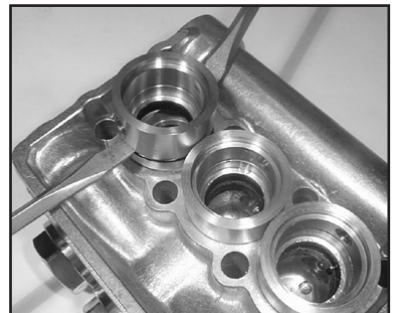

- 6) Remove seal case (20) and weep return rings (25) from the valve casing.



- 7) Remove the pressure rings (24) and v-sleeves (23 - Note: P422 & P423 pumps have a spacer ring) from the valve casing (26).



- 8) Remove the weep grooved seal (23 or 23B) together with pressure ring (24) (P420 and P425 only) out of the seal case (20). Check O-rings (21).

**IMPORTANT!** The grooved seal (23) on the high-pressure side is to be fitted carefully into the valve casing (26) using a screwdriver. Under no circumstances must the seal surface in the valve casing or the seal lip be damaged.

# Repair Instructions P420 / P420-0011 / P420-0021 / P422 / P423 and P425

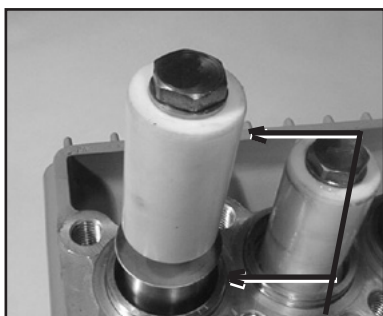

9) Check surfaces of plunger (16). Damaged surfaces cause accelerated seal wear. Deposits of all kinds must be removed from the plungers.

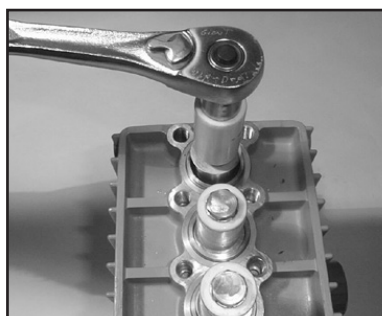

10) If the plunger pipe (16B), is damaged or worn, remove tension screw (16D) and plunger pipe (16B). Check and clean plunger surface (16A) and check flinger (16H). Cover thread of tension screw (16D) with a thin film of Loctite and tighten carefully to 20.7 ft.-lbs. (28 Nm).

### IMPORTANT!

Plunger surfaces are not to be damaged. If there are lime deposits in the pump, care must be taken that the drip-return bore in parts (25) and (26) ensure trouble-free drip-return.

11) If oil leaks under the plunger (16), the oil seals (19) need to be replaced. Remove oil plug (5) and drain oil. With the valve casing (26) and seal case (20) removed (ref. instructions #5 & 6), and plunger disassembled (ref. #10), carefully pry out the oil seal with a flat screwdriver and replace it with a new one. Make sure that the oil seal groove faces inward towards the oil.  
**NOTE:** Be careful not to score the crankcase guides where the oil seal sits and where the plunger base (16A) moves through the crankcase (1).

12) After installation of high pressure seals (23), place seal case (20) with weep seals & pressure ring installed, weep return ring (25) and high pressure weep return ring (24) over plungers. Slide valve casing over plungers and seat firmly. Replace the 8 socket head cap screws (34) and tighten to 30 ft.-lbs. (40 Nm) in a crossing pattern (as shown at right).

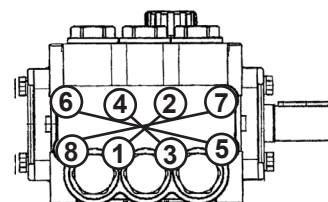

## Torque Specifications

### P420 / P420-0011 / P420-0021 / P422 / P423 and P425

<u>Position</u>	<u>Item#</u>	<u>Description</u>	<u>Lubrication</u>	<u>U.S</u>	<u>Metric</u>
3A	07186	Oil Sight Glass	Loctite 5910	106 in.-lbs.	12 Nm
5	07109	Oil Drain Plug		59 ft.-lbs.	80 Nm
5B	08092	Plug with Gasket		59 ft.-lbs.	80 Nm
6	01010	Screw		111 in.-lbs.	12.5 Nm
10	07114	Screw with Washer		133 in.-lbs.	15 Nm
15B	05349	Connecting Rod Screw		97 in.-lbs.	11 Nm
16D	08399	Tensioning Screw	Loctite 243	20.7 ft.-lbs.	28 Nm
32	08373	Plug	Loctite 243	107 ft.-lbs.	145 Nm
34	08396	Cap Screw	Lightly Oil	30 ft.-lbs.	40 Nm

Contact Giant Industries for service school information. Phone: (419) 531-4600

# PUMP SYSTEM MALFUNCTION

<u>MALFUNCTION</u>	<u>CAUSE</u>	<u>REMEDY</u>
The Pressure and/ or the Delivery Drops	Worn packing seals Broken valve spring Belt slippage Worn or Damaged nozzle Fouled discharge valve Fouled inlet strainer Worn or Damaged hose Worn or Plugged relief valve on pump Cavitation  Unloader	Replace packing seals Replace spring Tighten or Replace belt Replace nozzle Clean valve assembly Clean strainer Repair/Replace hose Clean, Reset, and Replace worn parts Check suction lines on inlet of pump for restrictions Check for proper operation
Water in crankcase	High humidity Worn seals	Reduce oil change interval Replace seals
Noisy Operation	Worn bearings  Cavitation	Replace bearings, Refill crankcase oil with recommended lubricant Check inlet lines for restrictions and/or proper sizing
Rough/Pulsating Operation with Pressure Drop	Worn packing Inlet restriction  Accumulator pressure Unloader Cavitation	Replace packing Check system for stoppage, air leaks, correctly sized inlet plumbing to pump Recharge/Replace accumulator Check for proper operation Check inlet lines for restrictions and/or proper size
Pressure Drop at Gun	Restricted discharge plumbing	Re-size discharge plumbing to flow rate of pump
Excessive Leakage	Worn plungers Worn packing/seals Excessive vacuum Cracked plungers Inlet pressure too high	Replace plungers Adjust or Replace packing seals Reduce suction vacuum Replace plungers Reduce inlet pressure
High Crankcase Temperature	Wrong Grade of oil Improper amount of oil in crankcase	Giant oil is recommended Adjust oil level to proper amount

<b>Preventative Maintenance Check List &amp; Recommended Spare Parts List</b>						
<b>Check</b>	<b>Daily</b>	<b>Weekly</b>	<b>50 hrs</b>	<b>Every 500 hrs</b>	<b>Every 1500 hrs</b>	<b>Every 3000 hrs</b>
Oil Level/Quality	X					
Oil Leaks	X					
Water Leaks	X					
Belts, Pulley		X				
Plumbing		X				
<b>Recommended Spare Parts</b>						
Oil Change (30.4 fl oz.) p/n 01154			X	X		
Seal Spare Parts (1 kit/pump) (see page 7 for kit list)					X	
Oil Seal Kit (1 kit/pump) (see page 7 for kit list)					X	
Valve Spare Parts (1 kit/pump) (see page 7 for kit list)						X

## Dimensions - P420/P420-0011/P420-0021/P422/P423 and P425 - Inches (mm)

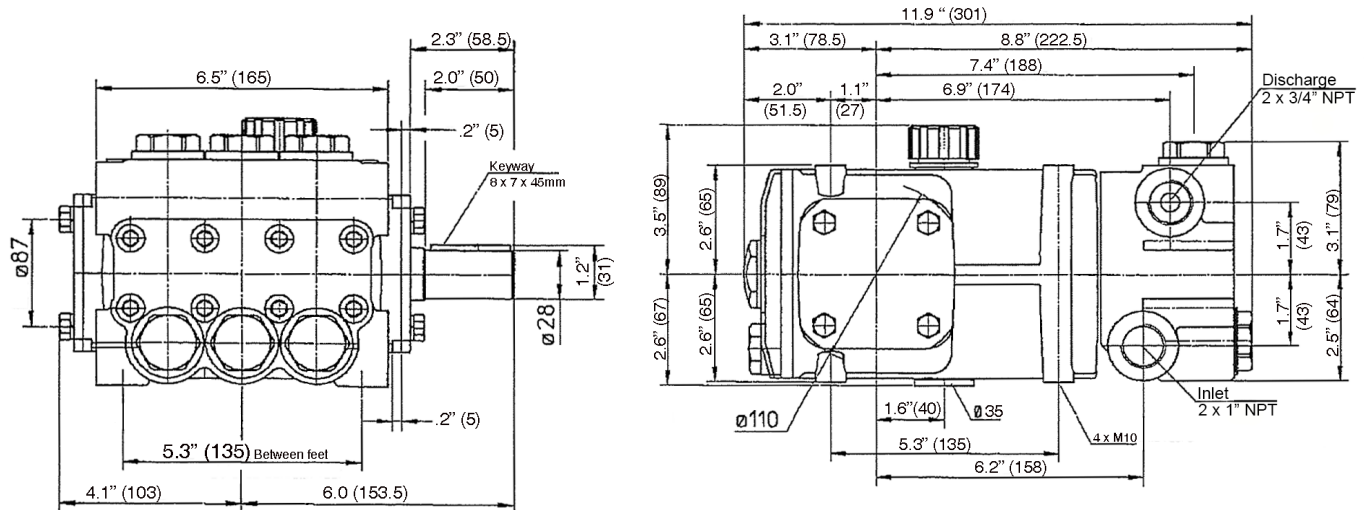

### GIANT INDUSTRIES LIMITED WARRANTY

Giant Industries, Inc. pumps and accessories are warranted by the manufacturer to be free from defects in workmanship and material as follows:

1. Five (5) years from the date of shipment for all pumps used in portable pressure washers with NON-SALINE, clean water applications.
2. Two (2) years from the date of shipment for Giant pumps used in car wash applications.
3. One (1) year from the date of shipment for all other Giant industrial and consumer pumps.
4. Six (6) months from the date of shipment for all rebuilt pumps
5. Ninety (90) days from the date of shipment for all Giant accessories.

This warranty is limited to repair or replacement of pumps and accessories of which the manufacturer's evaluation shows were defective at the time of shipment by the manufacturer. The following items are NOT covered or will void the warranty:

1. Defects caused by negligence or fault of the buyer or third party.
2. Normal wear and tear to standard wear parts.
3. Use of repair parts other than those manufactured or authorized by Giant.
4. Improper use of the product as a component part.
5. Changes or modifications made by the customer or third party.
6. The operation of pumps and or accessories exceeding the specifications set forth in the Operations Manuals provided by Giant Industries, Inc.

Liability under this warranty is on all non-wear parts and limited to the replacement or repair of those products returned freight prepaid to Giant Industries which are deemed to be defective due to workmanship or failure of material. A Returned Goods Authorization (R.G.A.) number and completed warranty evaluation form is required prior to the return to Giant Industries of all products under warranty consideration. Call (419)-531-4600 or fax (419)-531-6836 to obtain an R.G.A. number.

Repair or replacement of defective products as provided is the sole and exclusive remedy provided hereunder and the MANUFACTURER SHALL NOT BE LIABLE FOR FURTHER LOSS, DAMAGES, OR EXPENSES, INCLUDING INCIDENTAL AND CONSEQUENTIAL DAMAGES DIRECTLY OR INDIRECTLY ARISING FROM THE SALE OR USE OF THIS PRODUCT.

THE LIMITED WARRANTY SET FORTH HEREIN IS IN LIEU OF ALL OTHER WARRANTIES OR REPRESENTATION, EXPRESS OR IMPLIED, INCLUDING WITHOUT LIMITATION ANY WARRANTIES OR MERCHANTABILITY OR FITNESS FOR A PARTICULAR PURPOSE AND ALL SUCH WARRANTIES ARE HEREBY DISCLAIMED AND EXCLUDED BY THE MANUFACTURER.



**WARNING:** This product might contain a chemical known to the State of California to cause cancer, and birth defects or other reproductive harm.

For more information go to [www.P65Warnings.ca.gov](http://www.P65Warnings.ca.gov)

**GIANT**  
Performance Under Pressure

GIANT INDUSTRIES, INC., 900 N. Westwood Ave., Toledo, Ohio 43607  
PHONE (419) 531-4600, FAX (419) 531-6836, [www.giantpumps.com](http://www.giantpumps.com)  
© Copyright 2025 Giant Industries, Inc.

09/25 P400-22\_25mm.indd