

REPAIR INSTRUCTION - P200A-5100 SERIES

CAUTION EPDM o-rings must not come into contact with mineral oil or mineral grease. Use silicone grease only.

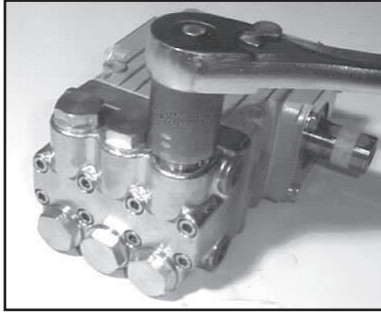

1. With a 22mm socket wrench, remove the (3) discharge valve plugs and (3) inlet valve plugs (32). Inspect the o-ring (33) for wear and replace if damaged.

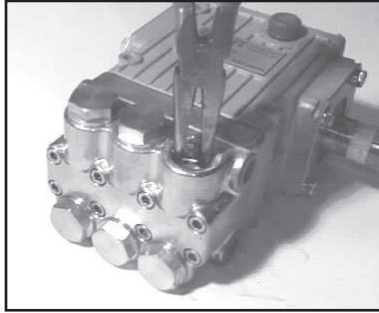

2. Using a needle nose pliers, remove the inlet and discharge valve assemblies (26A) and o-ring (31). Inspect all parts for wear and replace as necessary.



3. By inserting a small screw driver between the valve seat (27) and the valve spring retainer (30), the valve assembly can be separated.



4. Apply one drop of Loctite 243 to the valve plugs (32) and tighten to 55 ft.-lbs. (75 Nm).

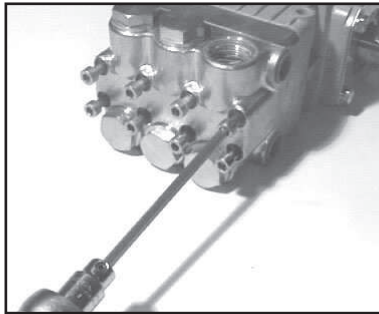

5. Next, use a 5mm allen wrench to remove the 8 socket head cap screws (34).

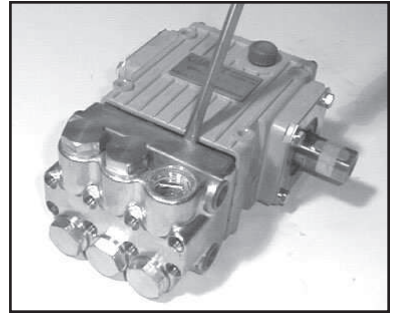

6. Carefully slide the valve casing (26) out over the plungers.

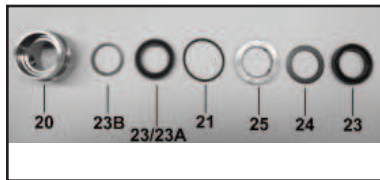

7. Remove the weep return ring (25), pressure ring (24), and v-sleeve (23) from the valve casing (26). Remove the rear v-sleeve (23 or 23A) and drip shield (23B) from the seal case (20). Inspect all parts, including o-ring (21) for wear and replace as necessary.

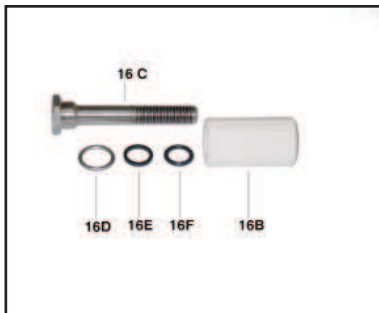

8. Check surfaces of plunger pipe (16B). A damaged surface will cause accelerated wear on the seals. Deposits of any kind must be carefully removed from the plunger surface. A damaged plunger must be replaced!

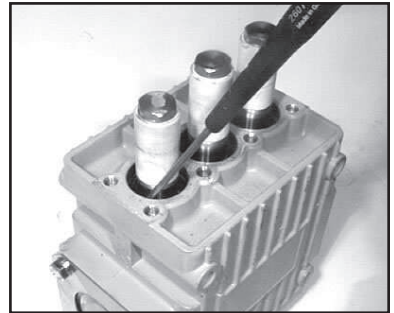

9. If the crankcase oil seals (19) are to be replaced, they can be removed by prying loose with a flat screwdriver. Take care not to make contact with the plunger.

REPAIR INSTRUCTION - P200A-5100 SERIES

Disassembly sequence of the *back* end of the P200A-5100 series pump.

- 1) Before you begin, drain the oil from the crankcase.
- 2) Remove the crankcase cover (3) and o-ring (4) from the crankcase (1). To remove the crankshaft (13), remove the bearing cover (7) and sight glass (8). Using a rubber mallet, remove the crankshaft axially through the connecting rods by tapping on the end of the shaft. Be careful not to bend or damage the connecting rods during crankshaft removal.
- 3) If the bearings (12A and 12B) and radial shaft seal (11) are still in the crankcase, remove them. Inspect both bearings and seal for wear and replace if necessary.
- 4) Remove the connecting rod (15) and plunger assembly(16). Remove the wrist pin (17) if necessary. Check the plunger bore in the crankcase for wear. Inspect parts and replace as necessary.
- 5) Should you find it necessary to service the plunger assembly (16) you can do so by removing the tension screw (16C). Replace crush washer (16D). **NOTE: Carefully flatten crush washer prior to replacing it. NOTE: Place side with line in the middle on the ceramic surface and use a hand press to cursh the washer prior to installing the tension screw.** Inspect all parts and replace as necessary.

Reassembly sequence of the P200A-5100 series pump

- 1) Reassemble plunger assembly (16) (apply a drop of Loctite to the tension screw (16C) threads) and the connecting rod (15) with wrist pin (17). Place assemblies in crankcase (1). Install crankshaft through connecting rods again being careful not to bend or otherwise damage the connecting rods.
- 2) Replace left and right side bearings (12A and 12B) if they were removed from the crankshaft. Be certain the bearings are pressed all the way onto the shaft and completely into the crankcase. Replace radial shaft seal (11), bearing cover (7), sight glass (8), and crankcase cover (3) with its o-ring (4).
- 3) If oil seals (19) were removed, replace with seal lip towards crankcase. Lubricate* seal before replacing.
- 4) Replace seal case (20) with o-rings (21) over plungers. Generously lubricate* o-rings and oil seal before reassembly. Replace drip shield (23B) and v-sleeve (23A) over plungers (16)..
- 5) Generously lubricate* v-sleeve (23) and assemble into valve casing (26). Assemble weep return ring (25) and pressure ring (24) over plungers (16). Slide valve casing over plungers and seat firmly. Replace the eight socket head cap screws (34) and tighten to 106 inch-pounds (12 Nm) in a crossing pattern (see below).
- 6) Re-install the six o-rings (31) and the six valve assemblies (27-30). Now replace the six valve plugs with o-rings (32 and 33) and tighten securely with a 22mm socket wrench to 55 foot-pounds (75 Nm).
- 7) Fill crankcase with 8.1 ounces (0.24 L) of oil.

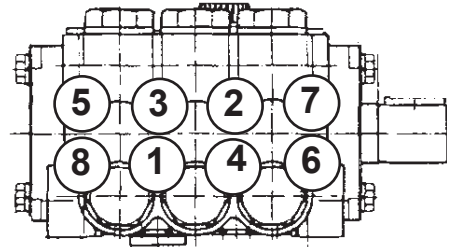

*For pumps with EPDM o-rings, use silicone grease only.