

MP Series

Triplex Ceramic Plunger Pump Operating Instructions/ Repair and Service Manual

Pump Models:

MP4120

MP4124

MP4126

MP4130

MP4135

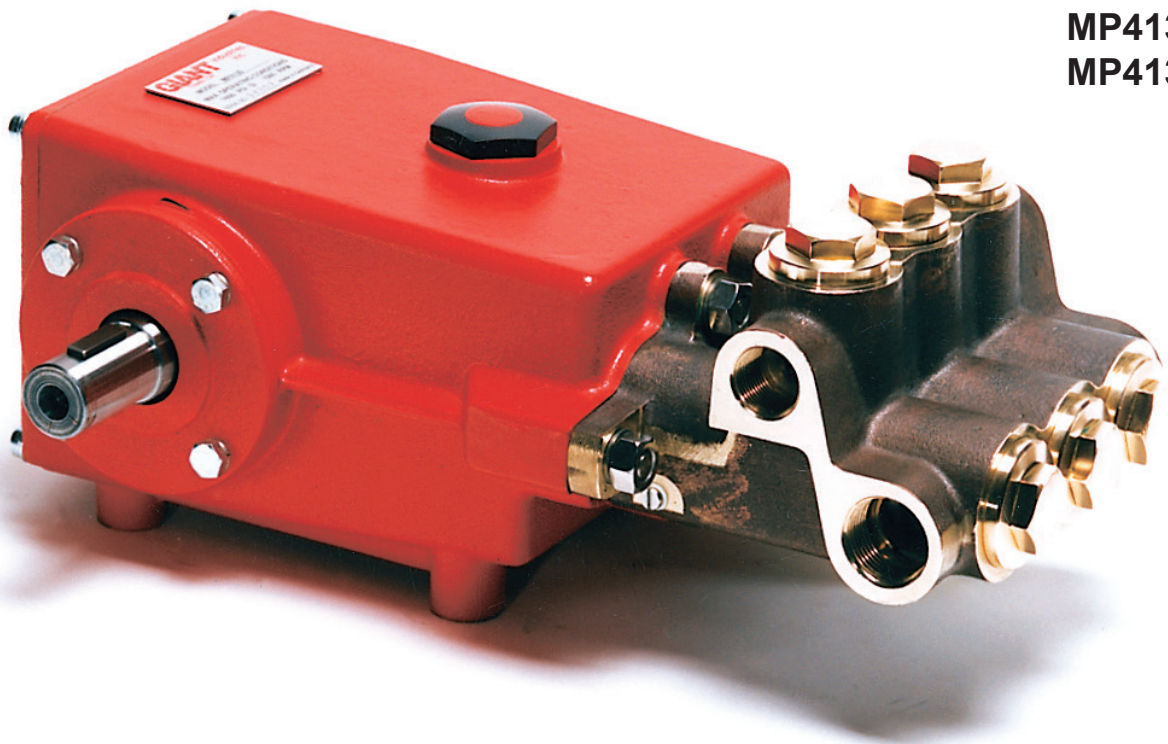

GIANT
Performance Under Pressure

Contents:

Installation Instructions:	page 2
Preventive Maintenance and Recommended Spare Parts List:	page 2
Pump Specifications:	page 3
Exploded View:	page 4
Parts List:	page 5
Repair Kits:	page 6
Torque Specifications:	page 6
Repair Instructions:	page 7
Dimensions:	back page
Warranty Information:	back page

Updated 04/23

INSTALLATION INSTRUCTIONS

Required NPSH refers to water: Specific weight 1kg/dm³, viscosity 1 °E at max. permissible revolutions.

Operation and Maintenance

Check oil level prior to starting and ensure trouble-free water supply.

Oil: Use 33.8 fl. ounces (1.0 liters) of Giant's part number 01154 or ISO VG 220 GL4 (e.g. Aral Degol BG220) or SAE 90 GL4 gear oil.

Initial change after 50 operating hours and then every 500 hours, after 6 months operation in any case.

Caution when operating in damp places or with high temperature fluctuations. Oil must be changed immediately, should condensate (frothy oil) occur in the gear box.

Keep NPSH under control.

Max. input pressure 145 PSI (10 bar), max. suction head -4.35 (-0.3 bar).

Safety Rules

Pump operation without safety valve as well as any excess in the temperature or speed limits automatically voids the warranty. The safety valve must be regulated in accordance with the guidelines for liquid spraying units so that the admissible operating pressure can not be exceeded by more than 10%.

When the pump is in operation, the open shaft end must be covered up by shaft protector (21), the driven shaft side and coupling by a contact protector.

Pressure in discharge line and in pump must be at zero before any maintenance to the pump takes place. Close up suction line. Disconnect fuses to ensure that the driving motor does not get switched on accidentally.

Make sure that all parts on the pressure side of the unit are vented and refilled, with pressure at zero, before starting the pump.

In order to prevent air, or an air/water-mixture being absorbed and to prevent cavitation occurring, the pump-NPSHR, positive suction head and water temperature must be kept under control.

Cavitation and/or compression of gases lead to uncontrollable pressure kicks which can ruin pump and unit parts and also be dangerous to the operator or anyone standing nearby.

Giant plunger pumps are suitable for pumping clean water and other non-aggressive or abrasive media with a specific weight similar to water.

Before pumping other liquids - especially inflammable, explosive and toxic media - the pump manufacturer must under all circumstances be consulted with regard to the resistance of the pump material. It is the responsibility of the equipment manufacturer and/or operator to ensure that all pertinent safety regulations are adhered to.

Preventative Maintenance Check-List & Recommended Spare Parts List						
Check	Daily	Weekly	50hrs	Every 500 hrs	Every 1500 hrs	Every 3000 hrs
Oil Level/Quality	X					
Oil Leaks	X					
Water Leaks	X					
Belts, Pulley		X				
Plumbing		X				
Recommended Spare Parts						
Oil Change (1 Quart)			X	X		
Seal Kit (1 kit/pump) (See page 6 for kit list)					X	
Valve Spare Parts (1 kit/pump) (See page 6 for kit list)						X

MP SERIES - PUMP SPECIFICATIONS

U.S. Measurements

	Max. Flow	Max. Pressure	Max. Speed	Power Required	Max. Temperature	Plunger Diameter	NPSH Required
Model	GPM	PSI	RPM	HP	°F	in	Ft-Head
MP4120	8.9	3625	1450	23.1	160	0.787	24.6
MP4124	12.8	2610	1450	24	160	0.945	27.9
MP4135	13.5	1885	1100	18.2	160	1.1	29.5
MP4130	15.4	1600*	1100	17.6	160	1.18	29.5
MP4126	17.9	1600	1100	20.4	160	1.18	N/A

*Intermittent rating of 2000 PSI

Metric Measurements

	Max. Flow	Max. Pressure	Max. Speed	Power Required	Max. Temperature	Plunger Diameter	NPSH Required
Model	L/min	bar	RPM	kW	°C	mm	mWs
MP4120	33.8	250	1450	17.2	70	20	7.5
MP4124	48.6	180	1450	17.9	70	24	8.5
MP4135	51.2	130	1100	13.6	70	28	9
MP4130	58.2	110*	1100	13.1	70	30	9
MP4126	67.7	110	1100	15.2	70	30	N/A

*Intermittent rating of 140 bar

Consult the factory for special requirements that must be met if the pump is to operate beyond one or more of the limits specified above.

Horsepower Ratings:

We recommend a 1.15 service factor be specified when selecting an electric motor as the power source.

To compute electric motor horsepower required, use the following formula: $HP = (GPM \times PSI) / 1450$.

The formula to determine the horsepower required for a gas engine is: $HP = (GPM \times PSI) / 1150$.

For the Application of a Hydraulic Motor:

To Determine the Torque of a Hydraulic Motor -- $(GPM \times PSI \times 36.77) / RPM = \text{Torque (in-lbs)}$

Calculating RPM / GPM of Pump:

A pump must be connected to an electric motor or gas or diesel engine with the correct ratio of pulleys and belts to attain the required speed and GPM. The use of a Variable Frequency Drive (VFD) may also be used to control the RPM of a properly sized electric motor when variable flows are required.

$$(\text{Max. Pump RPM} / \text{Rated Pump GPM}) \times \text{Required Pump GPM} = \text{Required Pump RPM}$$

To calculate a pulley diameter one (1) pulley diameter and the required pump RPM must be known:

$$(\text{Pump RPM} \times \text{Pump Pulley Diameter}) / \text{Motor RPM} = \text{Motor Pulley Diameter}$$

$$(\text{Motor RPM} \times \text{Motor Pulley Diameter}) / \text{Pump RPM} = \text{Pump Pulley Diameter}$$

Common Specifications:

Inlet Pressure 145 PSI (10 Bar)
 Crankshaft Diameter..... 1.10" (28 mm)
 Crankcase Oil Capacity 33.8 fl. oz. (1 L)
 Inlet Ports (2) 1" NPT
 Discharge Ports (2) 3/4" NPT
 Stroke (except MP4126)..... 1.02" (26 mm)
 Stroke (MP4126 only)..... 1.18" (30 mm)
 Weight 66 lbs (30 kg)
 Shaft Rotation..... Top of Pulley Toward Fluid End

Materials Used for MP Pumps:

Manifold Bronze
 Plungers Solid Ceramic Oxide
 Valves High Grade Stainless Steel
 Seals..... Nitrile with Fabric Reinforcing
 Gear End Spheroidal Cast Iron

Exploded View - MP Series

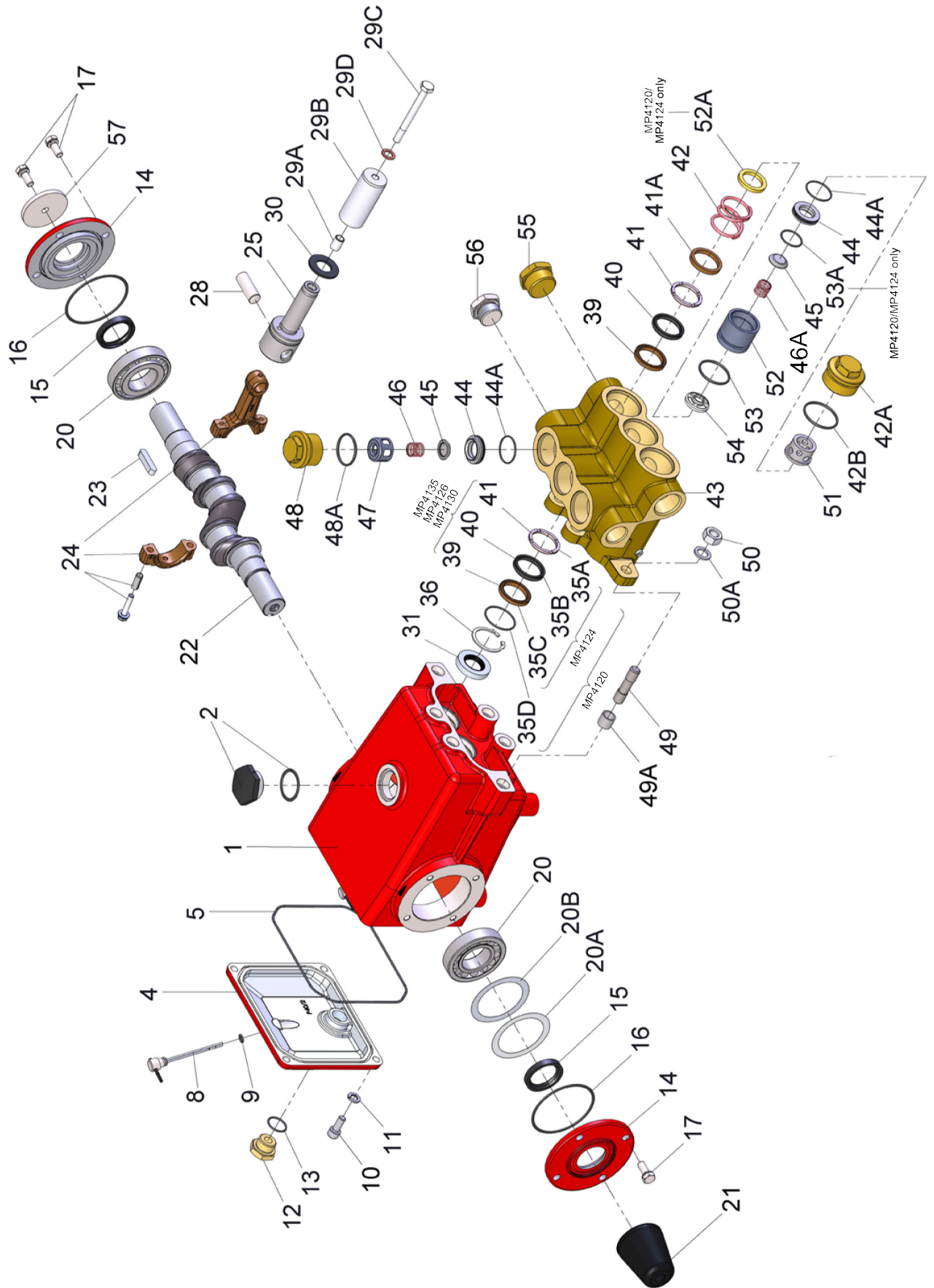

MP SERIES PARTS LIST AND REPAIR KITS

<u>ITEM</u>	<u>PART #</u>	<u>DESCRIPTION</u>	<u>QTY.</u>	<u>ITEM</u>	<u>PART#</u>	<u>DESCRIPTION</u>	<u>QTY.</u>
1	06100	Crankcase	1	41	07270	Support Ring (MP4120)	3
2	13000	Oil Filler Cap Assembly	1	41	06084	Support Ring (MP4124)	3
4	07243	Cover, Crankcase	1	41	07273	Support Ring (MP4126/MP4130)	6
5	07244	O-Ring, Crankcase Cover	1	41	06652	Support Ring (MP4135)	6
8	01008	Oil Dip Stick	1	41A	07329	Spacer Ring (MP4120/MP4124)	3
9	01009	O-Ring, Dip Stick	1	41A	07274	Spacer Ring (MP4126/MP4130/MP4135)	3
10	01010	Screw, Crankcase Cover	4	42	07275	Tension Spring (MP4120/MP4124)	3
11	01011-0400	Spring Washer	4	42	07353	Tension Spring (MP4126/MP4130/MP4135)	3
12	07109	Oil Drain Plug	1	42A	06102	Tension Plug (MP4120/MP4124)	3
13	06015	O-Ring, Oil Drain Plug	1	42A	06103	Tension Plug (MP4126/MP4130/MP4135)	3
14	07245	Bearing Cover	2	42B	07332	O-Ring (MP4120/MP4124)	3
15	07247	Seal, Crankshaft	2	42B	07354	O-Ring, Tension Plug (MP4126/MP4130/MP4135)	3
16	07627	O-Ring, Bearing Cover	2	43	06104	Manifold Head (MP4120/MP4124)	1
17	07114	Hex Screw, Bearing Cover	9	43	06105	Manifold Head (MP4126/MP4130/MP4135)	1
20	07248	Roller Bearing, Tapered	2	44	07280	Valve Seat	6
20A	07249	Fitting Disc	2	44A	07281	O-Ring, Valve Seat	6
20B	06962	Fitting Disc	2	45	06791-0100	Valve Plate	6
21	05375	Shaft Protector	1	46	07283	Discharge Valve Spring	3
22	07251	Crankshaft (except MP4126)	1	46A	06959	Inlet Valve Spring (MP4120/MP4130/MP4135)	3
22	04149	Crankshaft (MP4126 only)	1	46A	07283	Inlet Valve Spring (MP4124/MP4126)	3
23	13331	Key	1	47	07284	Spring Retainer, Discharge	3
24	07253	Connecting Rod Assembly	3	48	06108	Plug, (MP4120/MP4124)	3
25	07596	Crosshead Complete	3	48	07356	Plug, Brass (MP4126/MP4130/MP4135)	3
28	07255	Crosshead Pin	3	48A	07332	O-Ring, Plug	3
29A	07256	Centering Sleeve	3	49	06109	Stud, Manifold	6
29B	07262	Ceramic Plunger, 20mm (MP4120)	3	49A	07319	Shim, Stud	2
29B	13046	Ceramic Plunger, 24mm (MP4124)	3	50	07158	Nut, Manifold Stud	6
29B	07261	Ceramic Plunger, 30mm (MP4126/MP4130)	3	50A	07159	Spring Washer	6
29B	13005	Ceramic Plunger, 28mm (MP4135)	3	51	06110	Spacer	3
29C	13007	Tension Screw	3	52	06111	Valve Housing (MP4120/MP4124)	3
29D	07258	Seal Washer	3	52	06112	Valve Housing (MP4126/MP4130 /MP4135)	3
30	06136	Flinger	3	52A	07329	Spacer Ring (MP4120/MP4124 only)	3
31	07260	Crankcase Oil Seal	3	53	12057	O-Ring (MP4120/MP4124)	3
35A	07263	Support Ring (MP4120)	3	53	07332	O-Ring (MP4126/MP4130/MP4135)	3
35A	06079	Support Ring (MP4124)	3	53A	12027	O-ring (MP4120/MP4124 only)	3
35B	06064	V-Sleeve (MP4120)	3	54	06115	Spring Retainer, Inlet	3
35B	06080	V-Sleeve (MP4124)	3	55	06626	Plug, NPT, 1"	1
35C	07265	Pressure Ring (MP4120)	3	56	04732	Plug, NPT, 3/4"	1
35C	06081	Pressure Ring (MP4124)	3	57	13020	Disc for Crankshaft	1
35D	07266	O-Ring (MP4120)	3		04292	Manifold Assembly, MP4120 (35A-57)	
36	07267-0100	Snap Ring	3		03323	Manifold Assembly, MP4124 (35A-57)	
39	07268	Pressure Ring (MP4120)	3				
39	06082	Pressure Ring (MP4124)	3				
39	07271	Pressure Ring (MP4126/MP4130)	6				
39	13013	Pressure Ring (MP4135)	6				
40	07322	V-Sleeve (MP4120)	3				
40	06083	V-Sleeve (MP4124)	3				
40	07272	V-Sleeve (MP4126/MP4130)	6				
40	05687	V-Sleeve (MP4135)	6				
40	06137	V-Sleeve (MP4130HK)	3				
40A	07272	V-Sleeve (MP4130HK)	3				

MP SERIES PARTS LIST AND REPAIR KITS

Plunger Packing Kits

MP4120 # 09044

<u>Item</u>	<u>Part #</u>	<u>Description</u>	<u>Qty</u>
35B	06064	Rear V-Sleeve	3
35D	07266	Rear O-Ring	3
40	07322	V-Sleeve	3
42B	07332	O-Ring	3

MP4124 # 09300

<u>Item</u>	<u>Part #</u>	<u>Description</u>	<u>Qty</u>
35B	06080	Rear V-Sleeve	3
40	06083	V-Sleeve	3
42B	07332	O-Ring	3

MP4130/MP4126 # 09042

<u>Item</u>	<u>Part #</u>	<u>Description</u>	<u>Qty</u>
40	07272	V-Sleeve	6
42B	07354	O-Ring, Tension Plug	3

MP4135 # 09665

<u>Item</u>	<u>Part #</u>	<u>Description</u>	<u>Qty</u>
40	05687	V-Sleeve	6
42B	07354	O-Ring, Tension Plug	3

Valve Repair Kits

MP4120 # 09802

<u>Item</u>	<u>Part #</u>	<u>Description</u>	<u>Qty</u>
42B	07332	O-Ring Tension Plug	3
44	07280	Valve Seat	6
44A	07281	O-Ring, Valve-Seat	6
45	06791-0100	Valve Plate	6
46	07283	Valve Spring, Discharge	3
46A	06959	Valve Spring, Inlet	3
48A	07332	O-Ring, Tension Plug	3
53	12057	O-Ring	3
53A	12027	O-Ring	3

MP4124 # 09803

<u>Item</u>	<u>Part #</u>	<u>Description</u>	<u>Qty</u>
42B	07332	O-Ring Tension Plug	3
44	07280	Valve Seat	6
44A	07281	O-Ring, Valve-Seat	6
45	06791-0100	Valve Plate	6
46	07283	Valve Spring, Discharge	3
46A	07283	Valve Spring, Inlet	3
48A	07332	O-Ring, Tension Plug	3
53	12057	O-Ring	3
53A	12027	O-Ring	3

MP4126/MP4135 # 09809

<u>Item</u>	<u>Part #</u>	<u>Description</u>	<u>Qty</u>
42B	07354	O-Ring Tension Plug	3
44	07280	Valve Seat	6
44A	07281	O-Ring, Valve-Seat	6
45	06791-0100	Valve Plate	6
46	07283	Valve Spring, Discharge	3
46A	07283	Valve Spring, Inlet	3
48A	07332	O-Ring, Tension Plug	3
53	07332	O-Ring	3

MP4130 # 09810

<u>Item</u>	<u>Part #</u>	<u>Description</u>	<u>Qty</u>
42B	07354	O-Ring Tension Plug	3
44	07280	Valve Seat	6
44A	07281	O-Ring, Valve-Seat	6
45	06791-0100	Valve Plate	6
46	07283	Valve Spring, Discharge	3
46A	06959	Valve Spring, Inlet	3
48A	07332	O-Ring, Tension Plug	3
53	07332	O-Ring	3

MP SERIES TORQUE SPECIFICATIONS

Position	Item #	Description	Lubrication Info	Torque Amount
1	06100	Crankcase	Loctite 270	N/A
10	01010	Screw, Crankcase Cover		221 in.-lbs. (25 Nm)
12	07109	Oil Drain Plug		30 ft.-lbs. (40 Nm)
17	07114	Hex Screw, Bearing Cover		221 in.-lbs. (25 Nm)
24	07253	Hex Screw, Connecting Rod		106 in.-lbs. (12 Nm)
29C	13007	Bolt, Plunger	Loctite 243	247 in.-lbs. (28 Nm)
31	07260	Crankcase Oil Seal	Loctite 403	N/A
42A	06102/06103	Plug, Inlet		107 ft.-lbs. (145 Nm)
48	06108/07356	Plug, Discharge		107 ft.-lbs. (145 Nm)
50	07158	Nut, Manifold Stud		59 ft.-lbs. (80 Nm)

REPAIR INSTRUCTION - MP SERIES

To Check Valves

Suction Valves: Remove plugs (42A). Take out spacer pipe (51) and suction valve adaptor (52). For MP4120 and MP4124 pumps, remove spacer ring (52A) as well. Push valve parts and as necessary spacer pipe (51) out of suction valve adaptor using a soft tool.

Check and replace worn parts. Check O-rings (42B, 44A, 53 and 53A for MP4120/MP4124 only). Replace as necessary.

Discharge Valves: Remove plugs (48). Remove spring tension cap (47), valve spring (46) and valve plate (45) from the discharge valve. Take out valve seat (44) with a valve puller tool.

Check and replace worn parts.

Check O-rings (44A, 48A) and replace as necessary.

Tighten plugs (42A, 48) to 107 ft.-lbs. (145 Nm).

To Check Seals and Plunger Pipe

Remove plugs (42A). Loosen nuts (50) and remove valve casing (43) from plungers by pulling away from the crankcase (1). Take out spacer pipe (51), suction valve adaptor (52), tension spring (42) and seal-unit (39-41A).

Check surfaces of plunger pipes (29B) as damaged surfaces cause fast wear to the seals.

When replacing V-sleeves (40/40A), grease new seals with special grease from pump manufacturer before installing.

Check O-rings (42B, 44A, 53 and 53A for MP4120/MP4124 only) and replace as necessary.

Check rear v-sleeve (35 or 35B) and O-ring (35D for MP4120 only) after having removed snap ring (36) and replace as necessary.

If plunger pipe (29B) has to be replaced, loosen tension screw (29C) and remove it together with the plunger pipe (29B). Check and clean plunger (25) surfaces and install new plunger pipe and seal washer (29D).

Cover thread of tension screw (29C) with a fine film of liquid glue and tighten carefully to 247 in.-lbs. (28 Nm).

Important! Care must be taken that no glue gets between the plunger pipe (29B) and centring sleeve (29A). The plunger pipe should not be strained by eccentric tightening of tension screw, nor through dirt or damage to the front surface of the plunger as this could cause the plunger pipe to break.

Install spacer rings (41A, 52A - MP4120/MP4124 only), tension spring (42), spring tension disc (54), suction valve adaptor (52) and spacer pipe (51) and then tighten plug (42A) to 107 ft.-lbs. (145 Nm).

Install valve casing and tighten nuts (50) evenly to 59 ft.-lbs. (80 Nm).

To Dismantle Gear

After dismantling the valve casing (43) and plunger pipes (29B), drain the oil. Remove crankcase cover (4) and bearing covers (14).

Loosen connecting rod screws (24) and push stem of connecting rod halves as far as possible into the crosshead guides.

Important! Connecting rods (24) are marked for identification. Do not twist connecting rod halves. Connecting rods must be reinstalled in the same position on shaft journals.

While turning slightly, hit the crankshaft (22) to one side with a rubber hammer.

Important! Do not bend the front portion of the connecting rods. Check the crankshaft (22) and connecting rod (24) surfaces, shaft seals (15 and 31) and taper roller bearings (20).

To Reassemble

Using a soft tool, press in the outer bearing ring till the outer edge lines up with the outer edge of the bearing hole.

Remove bearing cover (14) together with shaft seal (15) and O-ring (16). Fit crankshaft (22) through bearing hole on the opposite side. Press in outer bearing (20), and tension it inwards with the bearing cover. Keep the crankshaft in vertical position and turn it slowly so that the taper rollers of the bearings touch the edge of the outer bearing ring.

Adjust axial bearing clearance to at least 0.1mm and maximum 0.15mm by placing fitting discs (20A/20B) under the bearing cover (14).

Important! After assembly has been completed, the crankshaft should turn easily with very little clearance.

Tighten connecting rod screws (24) to 106 in.-lbs. (12 Nm).

MP SERIES DIMENSIONS - Inches (mm)

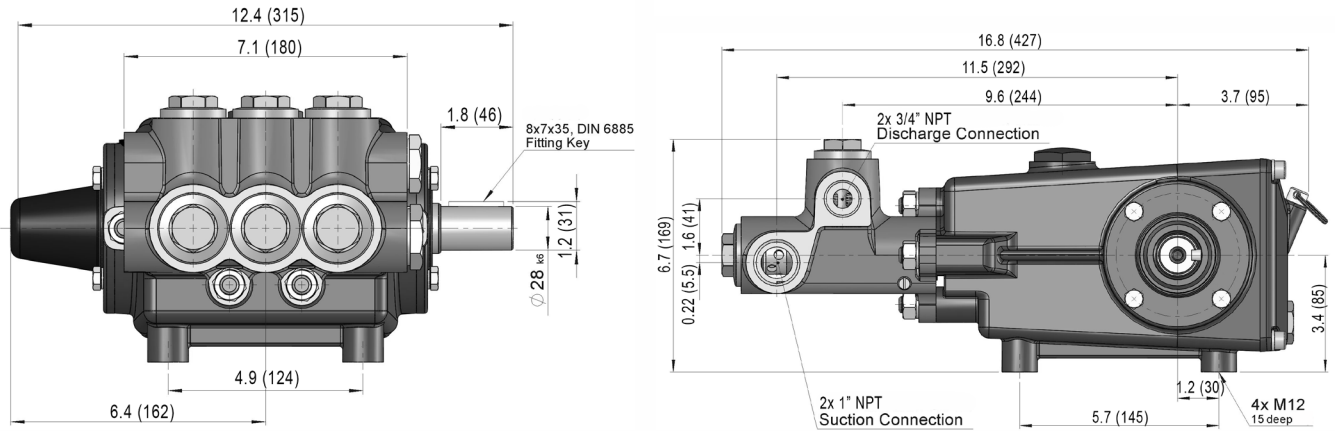

GIANT INDUSTRIES LIMITED WARRANTY

Giant Industries, Inc. pumps and accessories are warranted by the manufacturer to be free from defects in workmanship and material as follows:

1. Five (5) years from the date of shipment for all pumps used in portable pressure washers with NON-SALINE, clean water applications.
2. Two (2) years from the date of shipment for Giant pumps used in car wash applications.
3. One (1) year from the date of shipment for all other Giant industrial and consumer pumps.
4. Six (6) months from the date of shipment for all rebuilt pumps
5. Ninety (90) days from the date of shipment for all Giant accessories.

This warranty is limited to repair or replacement of pumps and accessories of which the manufacturer's evaluation shows were defective at the time of shipment by the manufacturer. The following items are NOT covered or will void the warranty:

1. Defects caused by negligence or fault of the buyer or third party.
2. Normal wear and tear to standard wear parts.
3. Use of repair parts other than those manufactured or authorized by Giant.
4. Improper use of the product as a component part.
5. Changes or modifications made by the customer or third party.
6. The operation of pumps and or accessories exceeding the specifications set forth in the Operations Manuals provided by Giant Industries, Inc.

Liability under this warranty is on all non-wear parts and limited to the replacement or repair of those products returned freight prepaid to Giant Industries which are deemed to be defective due to workmanship or failure of material. A Returned Goods Authorization (R.G.A.) number and completed warranty evaluation form is required prior to the return to Giant Industries of all products under warranty consideration. Call (419)-531-4600 or fax (419)-531-6836 to obtain an R.G.A. number.

Repair or replacement of defective products as provided is the sole and exclusive remedy provided hereunder and the MANUFACTURER SHALL NOT BE LIABLE FOR FURTHER LOSS, DAMAGES, OR EXPENSES, INCLUDING INCIDENTAL AND CONSEQUENTIAL DAMAGES DIRECTLY OR INDIRECTLY ARISING FROM THE SALE OR USE OF THIS PRODUCT.

THE LIMITED WARRANTY SET FORTH HEREIN IS IN LIEU OF ALL OTHER WARRANTIES OR REPRESENTATION, EXPRESS OR IMPLIED, INCLUDING WITHOUT LIMITATION ANY WARRANTIES OR MERCHANTABILITY OR FITNESS FOR A PARTICULAR PURPOSE AND ALL SUCH WARRANTIES ARE HEREBY DISCLAIMED AND EXCLUDED BY THE MANUFACTURER.



WARNING: This product might contain a chemical known to the State of California to cause cancer, and birth defects or other reproductive harm.
For more information go to www.P65Warnings.ca.gov