

Models

Triplex Ceramic
Plunger Pump
Operating Instructions/
Repair and Service Manual

LP122A/LP123/LP255

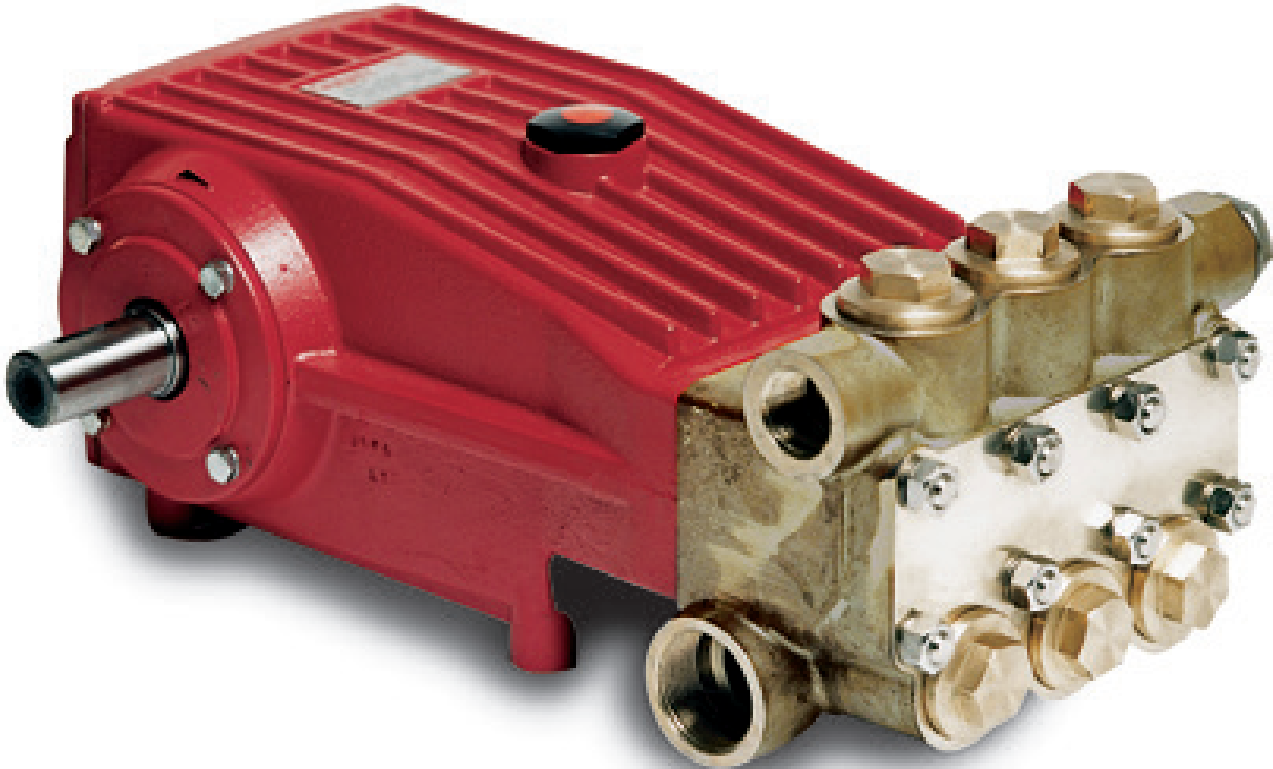

Contents:	
Installation Instructions:	page 2
Pump Specifications - LP122A	page 3
Pump Specifications - LP123:	page 3
Exploded View:	page 4
Parts List/Kits:	page 5
Pump Specifications - LP255:	page 6
Troubleshooting Guide:	page 7
Suggested Maintenance Schedule:	page 7
Repair Instructions/Torque Specs.:	pages 8-10
Dimensions:	page 11
Warranty Information:	back page

Updated 12/20

INSTALLATION INSTRUCTIONS

Operation and Maintenance

Check oil level prior to starting and ensure trouble free water supply.

IMPORTANT! If there is a **danger of frost**, the water in the pump and in the pump fittings (particularly the unloader valve) must be emptied. The second discharge port can also be used and the pump run “dry” for 1-2 minutes for this purpose.

Oil: Use only 118 fluid ounces (3.5 L) of SAE 90 Industrial gear lube oil. (Giant’s p/n 01154)

Initial change after 50 operating hours and then every 1000 operating hours, or after one year if used less.

Caution! When operating in damp places or with high temperature fluctuations, condensate (frothy oil) might occur in the gear box. In this situation, change the oil immediately. **Keep NPSH under control.**

Maximum input pressure is 145 PSI (10 bar), the maximum suction head is -4.35 PSI (-0.3 bar). Make sure that suction pulsation is sufficiently dampened. Water column resonance must be avoided.

Safety Rules

Pump operation without safety valve as well as any excess in temperature or speed limits automatically voids the warranty. The safety valve must be regulated in accordance with the guidelines for liquid spraying units so that the admissible operating pressure can not be exceeded by more than 10%.

When the pump is in operation, the open shaft end must be covered up by a shaft protector (21). For direct drive operations, the driven shaft side and coupling must have a guard over the connected area.

Pressure in discharge line and in pump must be at zero before any maintenance to the pump takes place. Close the fluid supply to the inlet port(s). Disconnect fuses to ensure that the driving motor does not accidentally get switched on. Make sure that all parts on the pressure side of the unit are vented and re-filled, with pressure at zero, before starting the pump.

In order to prevent air, or air/water mixture being absorbed and to prevent cavitation occurring, the pump-npshr, positive suction head and water temperature must be kept under control.

Required NPSH refers to water: Specific weight 0.0624 lb/ft³ (1kg/dm³), viscosity 1°E at maximum permissible revolutions.

Cavitation and/or compression of gases lead to uncontrollable pressure kicks which can ruin pump and unit parts and also be dangerous to the operator or anyone standing nearby.

Giant pumps are suitable for pumping clean water and other non-aggressive or abrasive media with a specific weight similar to water.

Before pumping other liquids - especially inflammable, explosive and toxic media - the pump manufacturer must under all circumstances be consulted with regard to the resistance of the pump material. It is the responsibility of the equipment manufacturer and/or operator to ensure that all pertinent safety regulations are adhered to.

LP122A/LP123 NPSHR Curve

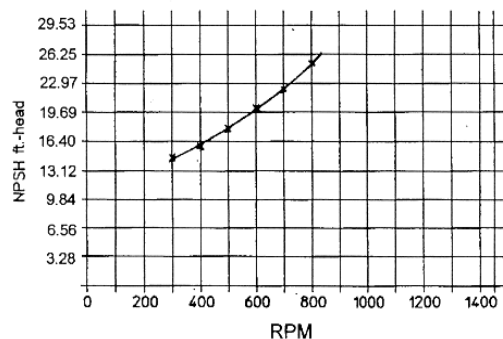

NOTE: Contact Giant Industries for Service School Information. Phone: (419)-531-4600

Specifications

Models LP122A/LP123

	U.S.	(Metric)
Volume	35.4 GPM	(134 l/m)
Discharge Pressure	1300 PSI	(90 Bar)
Maximum Inlet Pressure	90 PSI	(6 Bar)
Power Consumption	31.9 BHP	(23.8 kW)
Maximum Speed		800 RPM*
Plunger Diameter	1.65"	(42 mm)
Stroke	1.65"	(42 mm)
Crankcase Oil Capacity	118 fl.oz.	(3.5 liters)
Temperature of Pumped Fluids.....	140 °F	(60 °C)
Inlet Ports.....		2 x 1-1/2" NPT
Discharge Ports		2 x 1" NPT
Crankshaft Mounting.....		Either Side
Shaft Rotation	Top of Pulley Towards Fluid End	
Weight.....	125 lbs.	(57 Kg)
Crankshaft Diameter.....		(35 mm)
Valve Casing - LP122A.....		Aluminum Bronze
Valve Casing - LP123		Brass
Volumetric Efficiency @ 800 RPM.....		0.96
Mechanical Efficiency @ 800 RPM.....		0.85

*Pump speeds of 640 RPM and above require a minimum inlet pressure of 12 psig.

PULLEY INFORMATION

Pulley selection and pump speed are based on a 1725 RPM motor and "B" section belts. When selecting desired GPM, allow for a ±5% tolerance on pumps output due to variations in pulleys, belts and motors among manufacturers.

1. Select GPM required, then select appropriate motor and pump pulley from the same line.
2. The desired pressure is achieved by selecting the correct nozzle size that corresponds with the pump GPM.

HORSEPOWER INFORMATION

We recommend that a 1.15 service factor be specified when selecting an electric motor as the power source. To compute specific pump horsepower requirements, use the following formula:

$$HP = (GPM \times PSI) / 1450$$

LP122A/LP122A-4000/LP123 PULLEY SELECTION AND HORSEPOWER REQUIREMENTS								
GPM	PUMP PULLEY	MOTOR PULLEY	RPM	600 PSI	800 PSI	1000 PSI	1300 PSI	2000 PSI*
22.3	12.75"	3.95"	500	9.6	12.7	15.9	20.7	31.9
24.7	12.75"	4.35"	555	10.6	14.1	17.6	22.9	35.3
28.5	12.75"	4.95"	640	12.2	16.3	20.4	26.5	40.7
30.9	12.75"	5.35"	695	13.2	17.7	22.1	28.7	44.1
33.4	12.75"	5.75"	750	14.3	19.1	23.9	31.0	47.7
35.6	12.75"	6.15"	800	15.3	20.3	25.4	33.1	50.9
39.4	12.75"	6.50"	885*	16.9	22.5	28.1	36.6	56.3

***Intermittent duty only! - Consult factory!**

Exploded View - LP122A/LP123/LP255

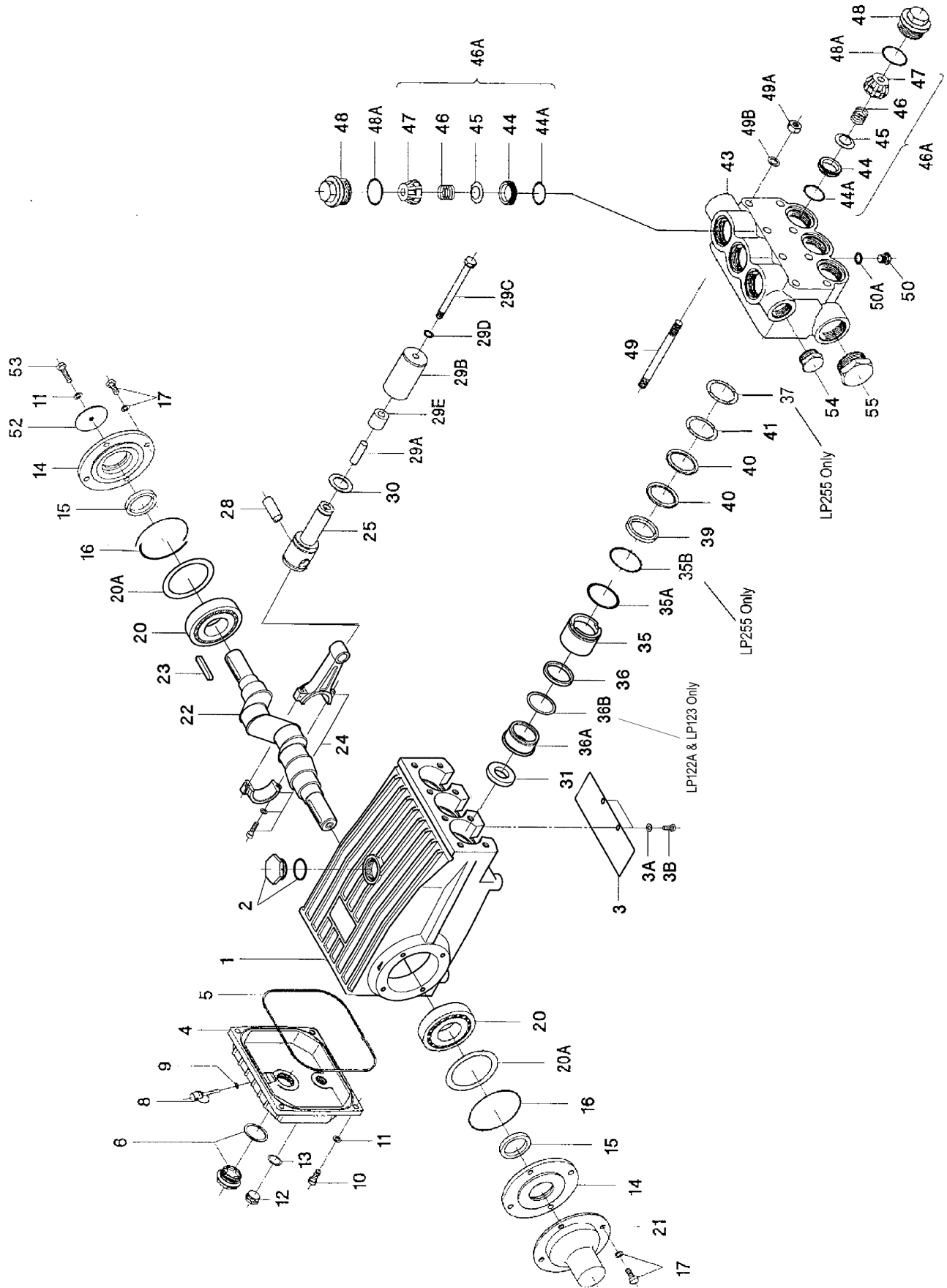

LP122A/LP123/LP255 PARTS LIST

A = LP122A

B = LP123

C = LP255

Item	Part #	Description	Qty.	Item	Part #	Description	Qty.
1	07759	Crankcase	1	31	07133	Radial Shaft Seal	3
2	13000	Oil Filler Plug	1	35	13342	Seal Sleeve, (A, B)	3
3	15940	Cover Plate (A)	1	35	06699	Seal Sleeve (C)	3
3A	07223-0100	Spring Washer (A)	2	35A	07740	O-Ring	3
3B	05051	Hexagon Screw (A)	1	35B	13141	O-Ring (C)	3
4	06085	Crankcase Cover	1	36	13415	V-Sleeve, Weep (A, B)	3
5	07104	O-Ring	1	36	13025	V-Sleeve, Weep (C)	3
6	05943	Oil Sight Glass W/Gasket (A)	1	36A	13416A	Pressure Ring, Weep, (A, B)	3
6	07186	Oil Sight Glass W/Gasket(B, C)	1	36A	06700	Pressure Ring (C)	3
8	06086	Oil Dipstick	1	36B	06174	Drip Shield (A, B)	3
9	01009	O-Ring	1	37	06701	Support Disc (C)	3
10	01010	Screw	4	39	07744	Pressure Ring, (A, B)	3
11	01011-0400	Spring Washer, (A, B)	5	39	13026	Pressure Ring (C)	3
12	07109	Oil Drain Plug	1	40	07745	V-Sleeve (A, B)	6
13	07182	Gasket	1	40	13027	V-Sleeve (C)	6
14	07111	Bearing Cover	2	41	07746	Support Ring, (A, B)	3
15	07112	Crankshaft Seal	2	41	06702	Support Ring (C)	3
16	07113	O-Ring	2	43	13343	Valve Casing, (A)	1
17	07114	Hex Screw	8	43	06703	Valve Casing, (B, C)	1
20	07116	Taper Roller Bearing	2	44	07748	Valve Seat	6
20A	07117	Fitting Disc, 0.1mm	1	44A	07150	O-Ring	6
20B	13001	Fitting Disc, 0.15mm	2	45	07749	Valve Plate	6
20C	04091	Shim	3	46	07750	Valve Spring	6
21	05376	Shaft Protector	1	46A	07751	Valve Assy. Complete (#44, 44A, 45, 46, & 47)	6
21A	05377	Shaft Guard Holder	1	47	07752	Spring Retainer	6
22	13242	Crankshaft	1	48	07753	Plug, (A)	6
23	13243	Key	1	48	06504	Plug, (B, C)	6
24	13340	Connecting Rod Assy.	3	48A	12055	O-Ring	6
24A	13277	Hex Screw	6	49	07157	Stud Bolt	8
24B	13278	Spring Washer	6	49A	07158	Nut	8
25	13341	Crosshead Plunger Base Assy.	3	49B	07159	Washer	8
28	13232	Crosshead Pin	3	50	07423	Plug, (A, B, C)	1
29A	07735	Centering Sleeve	3	50A	07161	Gasket	1
29B	07736	Plunger Pipe (A, B)	3	52	13020	Disk for Crankshaft	1
29B	13022	Plunger Pipe (C)	3	53	06607	Hexagon Screw	1
29C	07737	Plunger Bolt	3	54	07756	Plug 1" NPT, (A)	1
29D	07755	Copper Gasket	3	54	06626	Plug 1" NPT, (B, C)	1
29E	06087	Spacer Pipe	3	55	07757	Plug 1-1/2" NPT, (A)	1
30	07779	Flinger	3	55	06627	Plug, 1-1/4" NPT, (B, C)	1

NOTE: For LP122 pumps manufactured prior to 5/94, which need weep seal replacement, change the pressure ring (36) to the newer style (p/n 13416) and use the new style weep seal (p/n 13415) in your pumps.

LP122A/LP123/LP255 PUMP REPAIR KITS

Plunger Packing Kits

09477 (LP122A, LP123)
(for pumps manufactured after 4/98)

Item	Part #	Description	Qty.
35A	07740	O-ring	3
36	13415	V-Sleeve, Weep	3
40	07745	V-Sleeve	6

09535 (LP255)

Item	Part #	Description	Qty.
35A	07740	O-ring	3
35B	13141	O-ring	3
36	13025	V-Sleeve weep	3
40	13027	V-Sleeve	6

Valve Assembly Kit - #09136

Item	Part #	Description	Qty.
46A	07751	Valve Assembly, Complete	3
48A	12055	O-ring	3

Oil Seal Kit - #09577

Item	Part #	Description	Qty.
31	07133	Radial Shaft Seal	3

Specifications

Model LP255

	U.S.	(Metric)
Volume.....	26.0 GPM.....	(98 l/min)
Discharge Pressure	2175 PSI	150 Bar)
Inlet Pressure.....	Up to 90 PSI.....	Up to 6.2 Bar)
Speed		Up to 1000 RPM
Plunger Diameter.....	1.26"	(32 mm)
Stroke	1.65"	(42 mm)
Crankcase Oil Capacity	116 fl.oz.....	(3.43 liters)
Temperature of Pumped Fluids.....	Up to 140°F	(60 °C)
Inlet Ports.....		2 x 1-1/2" NPT
Discharge Ports		2 x 1" NPT
Crankshaft Mounting.....		Either Side
Shaft Rotation	Top of Pulley Towards Fluid End	
Weight.....	125 lbs.	(57 Kg)
Crankshaft Diameter.....	1.38"	(35 mm)
Valve Casing.....		Brass
Volumetric Efficiency @ 800 RPM.....		0.96
Mechanical Efficiency @ 800 RPM.....		0.85

PULLEY INFORMATION

Pulley selection and pump speed are based on a 1725 RPM motor and "B" section belts. When selecting desired GPM, allow for a ±5% tolerance on pumps output due to variations in pulleys, belts and motors among manufacturers.

1. Select GPM required, then select appropriate motor and pump pulley from the same line.
2. The desired pressure is achieved by selecting the correct nozzle size that corresponds with the pump GPM.

HORSEPOWER INFORMATION

We recommend that a 1.15 service factor be specified when selecting an electric motor as the power source. To compute specific pump horsepower requirements, use the following formula:

$$HP = (GPM \times PSI) / 1450$$

LP255 PULLEY SELECTION AND HORSEPOWER REQUIREMENTS							
PUMP PULLEY	MOTOR PULLEY	RPM	GPM	1000 PSI	1500 PSI	2000 PSI	2175 PSI
12.75"	3.95"	500	13	9.0	13.5	18.1	19.6
12.75"	4.35"	640	16.6	11.5	17.3	23.1	25.1
12.75"	4.95"	750	19.5	13.5	20.3	27.1	29.5
12.75"	5.35"	805	20.9	14.5	21.8	29.0	31.6
12.75"	5.75"	865	22.5	15.6	23.4	31.3	34.0
12.75"	6.15"	920	23.9	16.6	24.9	33.2	36.1
12.75"	6.50"	1000	26	18.1	27.1	36.1	39.3

PUMP SYSTEM MALFUNCTION

<u>MALFUNCTION</u>	<u>CAUSE</u>	<u>REMEDY</u>
The Pressure and/or the Delivery Drops	Worn packing seals Broken valve spring Belt slippage Worn or Damaged nozzle Fouled discharge valve Fouled inlet strainer Worn or Damaged hose Worn or Plugged relief valve on pump Cavitation Unloader	Replace packing seals Replace spring Tighten or Replace belt Replace nozzle Clean valve assembly Clean strainer Repair/Replace hose Clean, Reset, and Replace worn parts Check suction lines on inlet of pump for restrictions Check for proper operation
Water in crankcase	High humidity Worn seals	Reduce oil change interval Replace seals
Noisy Operation	Worn bearings Cavitation	Replace bearings, Refill crankcase oil with recommended lubricant Check inlet lines for restrictions and/or proper sizing
Rough/Pulsating Operation with Pressure Drop	Worn packing Inlet restriction Accumulator pressure Unloader Cavitation	Replace packing Check system for stoppage, air leaks, correctly sized inlet plumbing to pump Recharge/Replace accumulator Check for proper operation Check inlet lines for restrictions and/or proper size
Pressure Drop at Gun	Restricted discharge plumbing	Re-size discharge plumbing to flow rate of pump
Excessive Leakage	Worn plungers Worn packing/seals Excessive vacuum Cracked plungers Inlet pressure too high	Replace plungers Adjust or Replace packing seals Reduce suction vacuum Replace plungers Reduce inlet pressure
High Crankcase Temperature	Wrong Grade of oil Improper amount of oil in crankcase	Giant oil is recommended Adjust oil level to proper amount

Preventative Maintenance Check-List & Recommended Spare Parts List						
Check	Daily	Weekly	50hrs	Every 500 hrs	Every 1500 hrs	Every 3000 hrs
Oil Level/Quality	X					
Oil Leaks	X					
Water Leaks	X					
Belts, Pulley		X				
Plumbing		X				
Recommended Spare Parts						
Oil Change (1 Gallon) p/n 1154			X	X		
Seal Spare Parts (1 kit/pump) (See page 5 for kit list)					X	
Oil Seal Kit (1 kit/pump) (See page 5 for kit list)					X	
Valve Spare Parts (1 kit/pump) (See page 5 for kit list)						X

LP122A/LP123/LP255 - Repair Instructions



1. With a 30mm wrench, remove the six (6) plugs (48) from the valve casing (43). Inspect the O-rings (48A) and replace if necessary. Remove the complete valve assembly (46A) by threading a 12mm bolt into the spring retainer and pulling straight out.

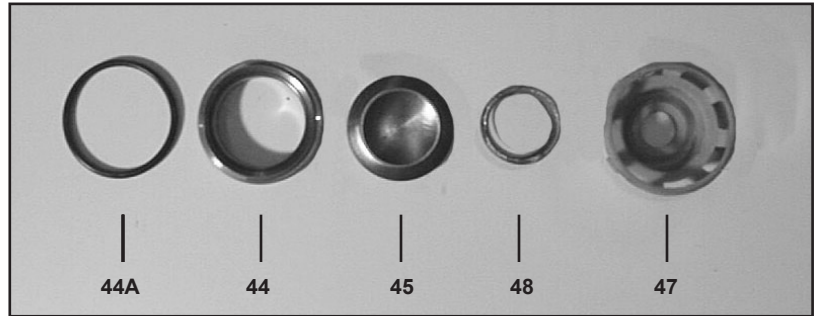

2. To disassemble the valve, screw the bolt into the retainer until the valve plate (45) presses the valve seat (44) out of the spring retainer. Examine all parts and replace if necessary. If the seat doesn't come out, use a valve puller to remove.

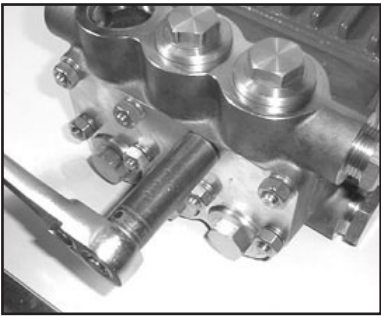

3. Remove the eight (8) hex nuts (49A) with a 19mm wrench. Tap the back of the manifold (43) with a rubber mallet to dislodge and slide off the studs.
5. If there are signs of oil leaking through the plunger oil seals, then replacement is necessary. Dissassemble the gear end and push out the seals from the back of the pump.

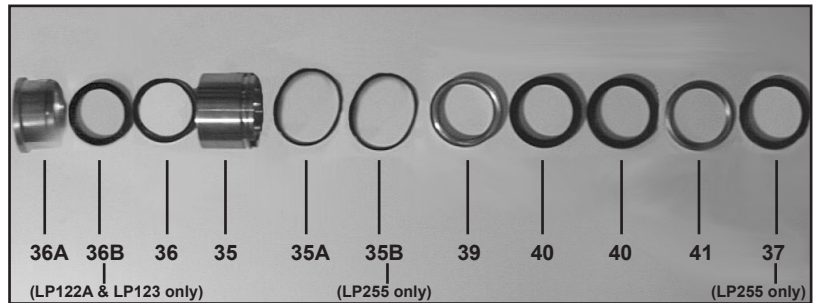

4. Remove the seal sleeve (35) from the manifold and/or crankcase. Remove the pressure rings (39&36A), drip shield (36B for LP122A & LP123 only), v-sleeves (40&36), support ring (41) and O-rings (35A and 35B in LP255A only) from the manifold and seal sleeve, respectively. For LP255 only, remove support ring (37). Examine seals carefully and replace if worn. Clean all parts.

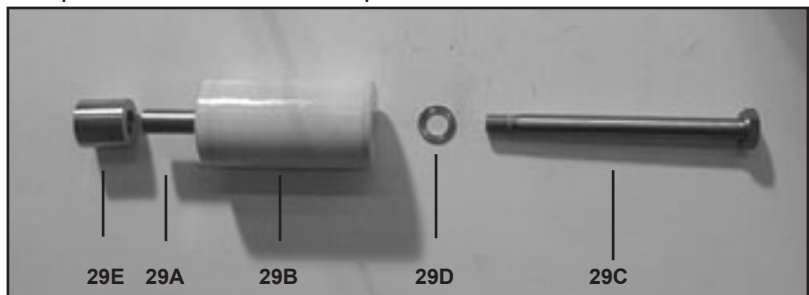

6. Inspect surface of plunger pipe (29B) carefully. Remove any chemical or mineral deposits taking care not to damage the surface of the plunger. If plunger pipe is worn, remove the plunger bolt (29C), plunger pipe (29B) and spacer (29E). Replace worn parts necessary. **Note: Always use a new copper gasket (29) when repairing the plunger assembly.**

LP122A/LP123/LP255 - Repair Instructions

TO REASSEMBLE PROCEED AS FOLLOWS:

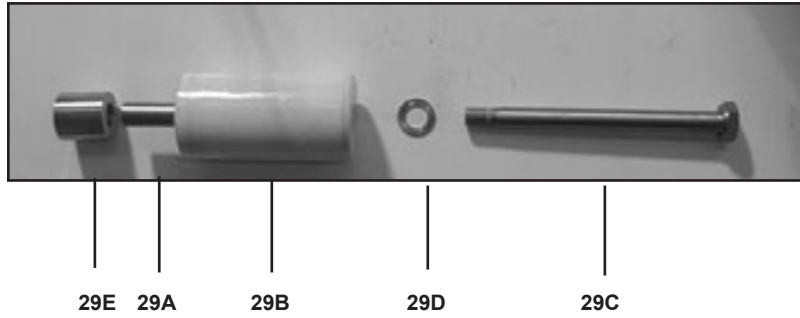

7. If previously disassembled thoroughly clean all exposed surfaces on the spacer (29E) and all exposed threads on the plunger bolt (29C) and the steel plunger base (25). Threads **MUST** be free of old loc-tite and any other material such as oil, grease, etc. This is necessary to ensure proper curing of new loc-tite. Giant recommends cleaning the threads with acetone or other suitable cleaner. Reassemble plunger assembly parts (29A, 29B, & 29E) using a new copper gasket (29D) and the cleaned plunger bolt (29C). Slide the bolt through the center of the four (4) pieces so that the threaded end is exposed. Apply several drops of loc-tite 243 (or equivalent) adhesive to the threads. Thread into steel plunger base and tighten to 26 ft.-lbs. (35 Nm). **BE CERTAIN ALL PARTS ARE CENTERED WITH THE BOLT!**

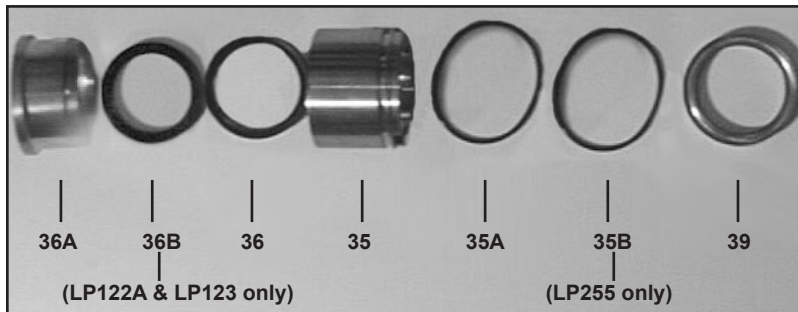

8. Lubricate weep seal (36). Place, weep seal (36), and pressure ring (36A) into the seal sleeve (35). Assemble the O-ring (35A and 35B for LP255 only) onto seal sleeve and lubricate.

9. For LP255 pumps, insert support ring (37) into valve casing (43). Place support ring (41) and v-sleeves (40) into valve casing.

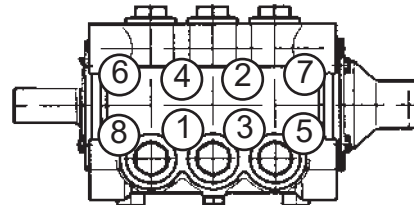

10. Place entire manifold/seal sleeve assembly over the studs and push firmly until seated against the crankcase.

11. Tighten hex nuts (49A) in a crosswise pattern (shown above) to 60 ft.-lbs. (81 Nm).

LP122A/LP123/LP255 - Repair Instructions



12. Next, place valve assemblies (46A) into manifold after first lubricating the O-ring (44A). Seat firmly into manifold.



13. Replace plug with O-ring (48, & 48A) and tighten to 160 ft.-lbs. (217 Nm).

14. Fill crankcase with approximately 116 fluid ounces of Giant oil or equivalent SAE 90 industrial gear oil and check oil level of the crankcase with the dipstick. Proper level is center of two lines. Reinstall your Giant LP pump into your system.

LP122A/LP123/LP255 TORQUE SPECIFICATIONS

Item #	Part #	Description	Lubrication Info	Torque Amount
1	07759	Crankcase	Molycote Cu-Paste	
6	05943/07186	Oil Sight Glass w/Gasket	Loctite 572	29 ft.-lbs. (40 Nm)
10	01010	Screw		221 in.-lbs. (25 Nm)
12	07109	Oil Drain Plug		29 ft.-lbs. (40 Nm)
17	07114	Hex Screw		221 in.-lbs. (25 Nm)
24A	13277	Hex Screw		22 ft.-lbs. (30 Nm)
29C	07737	Plunger Bolt	Loctite 243	26 ft.-lbs. (25 Nm)
31	07133	Radial Shaft Seal	Loctite 403	
48	07753/07423	Plug	Loctite 243	107 ft.-lbs. (145 Nm)
49A	07158	Nut		59 ft.-lbs. (80 Nm)
49	07157	Stud Bolt	Loctite 270	

Contact Giant Industries or your local distributor for maintenance of the gear end of your pump. Phone: 419/531-4600

**Contact Giant Industries for service school information.
Phone: (419) 531-4600**

LP122A/LP123/LP255 Dimensions (mm)

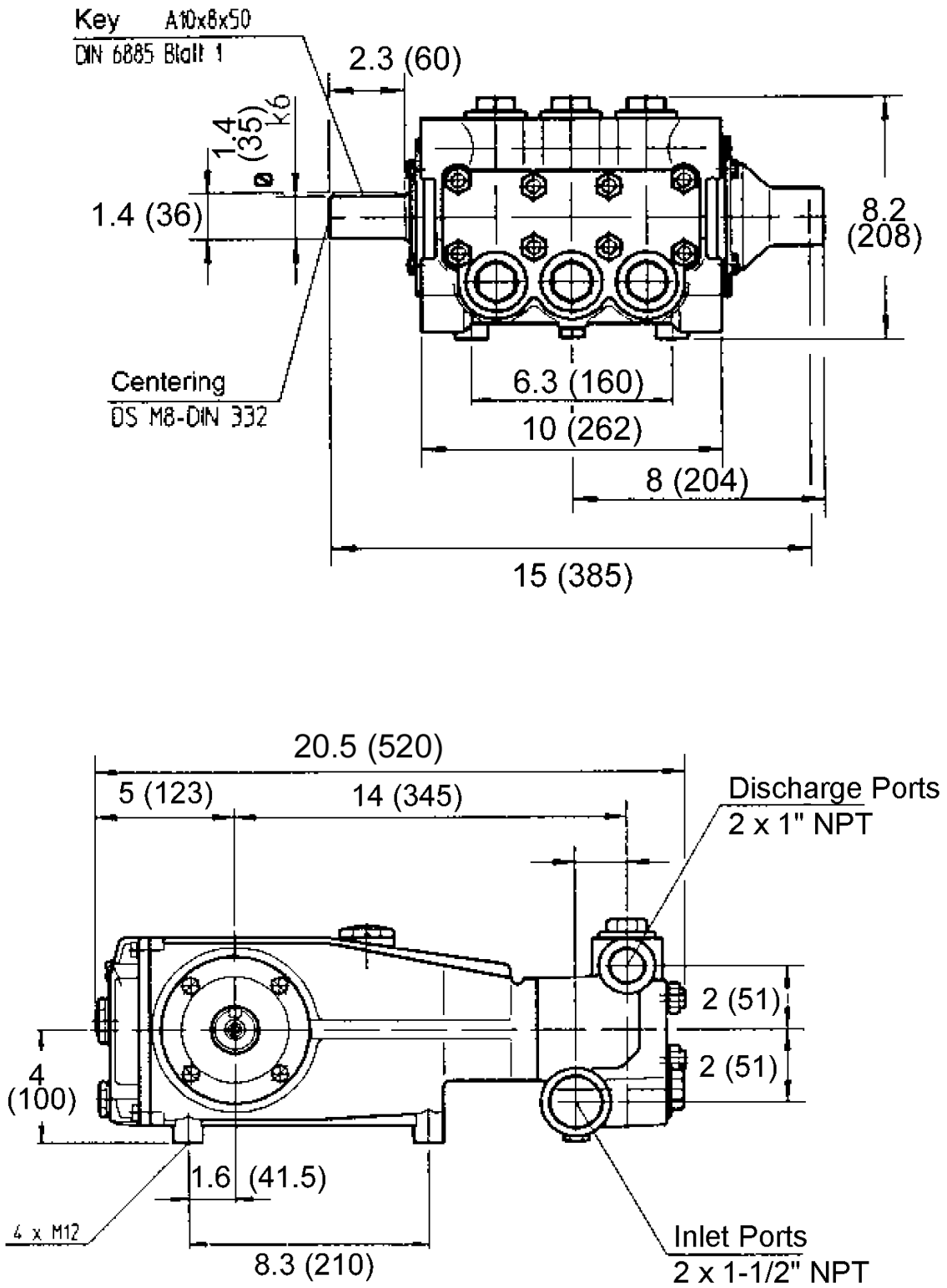

GIANT INDUSTRIES LIMITED WARRANTY

Giant Industries, Inc. pumps and accessories are warranted by the manufacturer to be free from defects in workmanship and material as follows:

1. Five (5) years from the date of shipment for all pumps used in portable pressure washers with NON-SALINE, clean water applications.
2. Two (2) years from the date of shipment for Giant pumps used in car wash applications.
3. One (1) year from the date of shipment for all other Giant industrial and consumer pumps.
4. Six (6) months from the date of shipment for all rebuilt pumps
5. Ninety (90) days from the date of shipment for all Giant accessories.

This warranty is limited to repair or replacement of pumps and accessories of which the manufacturer's evaluation shows were defective at the time of shipment by the manufacturer. The following items are NOT covered or will void the warranty:

1. Defects caused by negligence or fault of the buyer or third party.
2. Normal wear and tear to standard wear parts.
3. Use of repair parts other than those manufactured or authorized by Giant.
4. Improper use of the product as a component part.
5. Changes or modifications made by the customer or third party.
6. The operation of pumps and or accessories exceeding the specifications set forth in the Operations Manuals provided by Giant Industries, Inc.

Liability under this warranty is on all non-wear parts and limited to the replacement or repair of those products returned freight prepaid to Giant Industries which are deemed to be defective due to workmanship or failure of material. A Returned Goods Authorization (R.G.A.) number and completed warranty evaluation form is required prior to the return to Giant Industries of all products under warranty consideration. Call (419)-531-4600 or fax (419)-531-6836 to obtain an R.G.A. number.

Repair or replacement of defective products as provided is the sole and exclusive remedy provided hereunder and the MANUFACTURER SHALL NOT BE LIABLE FOR FURTHER LOSS, DAMAGES, OR EXPENSES, INCLUDING INCIDENTAL AND CONSEQUENTIAL DAMAGES DIRECTLY OR INDIRECTLY ARISING FROM THE SALE OR USE OF THIS PRODUCT.

THE LIMITED WARRANTY SET FORTH HEREIN IS IN LIEU OF ALL OTHER WARRANTIES OR REPRESENTATION, EXPRESS OR IMPLIED, INCLUDING WITHOUT LIMITATION ANY WARRANTIES OR MERCHANTABILITY OR FITNESS FOR A PARTICULAR PURPOSE AND ALL SUCH WARRANTIES ARE HEREBY DISCLAIMED AND EXCLUDED BY THE MANUFACTURER.



WARNING: This product might contain a chemical known to the State of California to cause cancer, and birth defects or other reproductive harm.
For more information go to www.P65Warnings.ca.gov