

Model GP7150-4000

Triplex Ceramic
Plunger Pump Manual

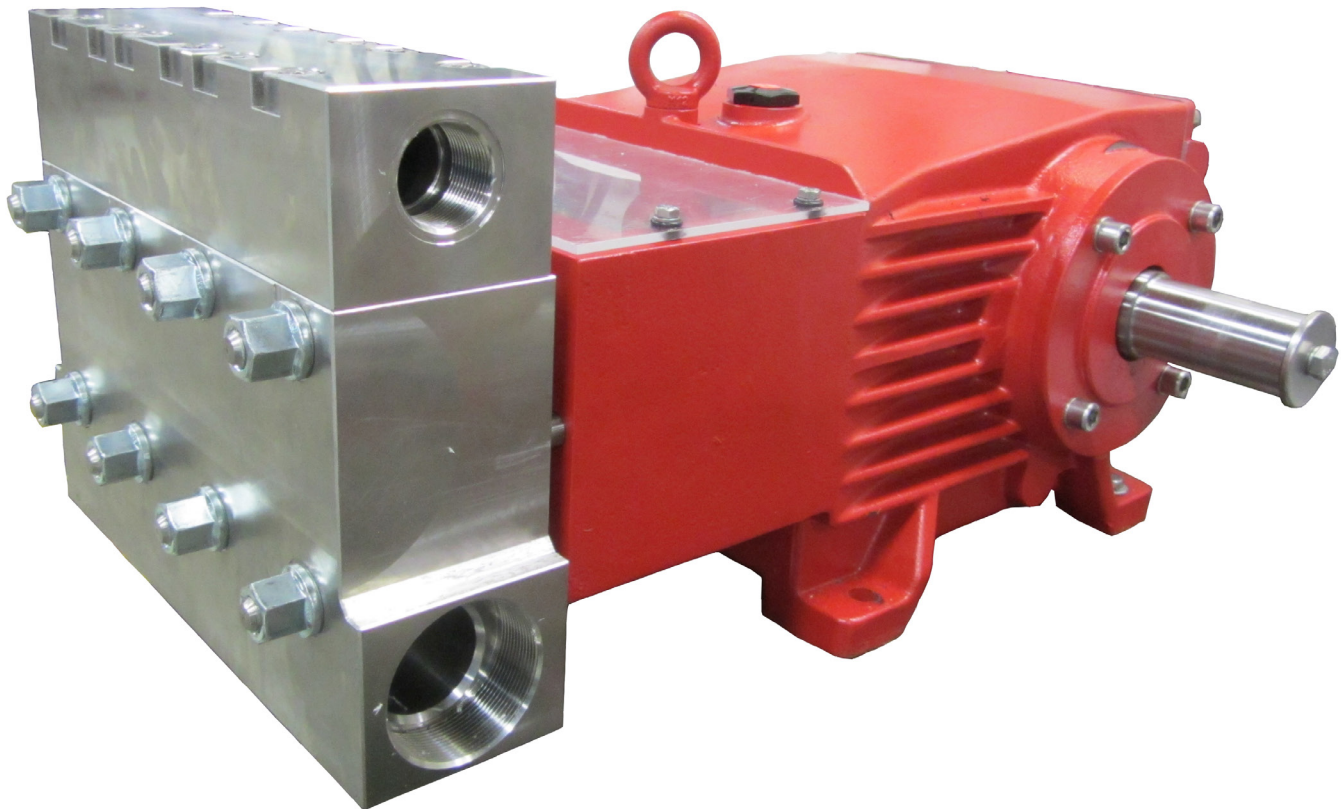

GIANT
Performance Under Pressure

Contents:

Installation Instructions:	page 2
Pump Specifications:	page 3
Exploded View:	page 4
Parts List/Kits:	page 5
Repair Instructions:	page 6
Preventive Maintenance and Spare Parts List:	page 7
Torque Specifications:	page 7
Dimensions:	back page
Warranty Information:	back page

INSTALLATION INSTRUCTIONS

Figures given for maximum pressure and maximum speed (rpm) apply to interval operation. When the pump is used in continual operation and/or with water warmer than 40°C (100°F), these values must be reduced by 10%.

Required NPSH refers to water: Specific weight 1kg/dm³, viscosity 1cE at max. permissible revolutions, using both suction connections.

IMPORTANT! Use of both suction connections is imperative in order to ensure cavitation-free operation and optimal suction conditions. If only one connection is used, a safety margin of one meter has to be added to the required NPSH.

Operation and Maintenance

Check oil level prior to starting and ensure trouble-free water supply.

IMPORTANT! If there is a danger of frost, the water in the pump and in the pump fittings (particularly the unloader valve) must be emptied. The second discharge port can also be used and the pump run "dry" for 1-2 minutes for this purpose.

Oil: Use only 1.6 gallons (6.0 litres) of Giant's p/n 01154 or ISO VG 220 (e.g. Aral Degol BG220) or SAE 90 gear oil. We recommend ISO VG 68 (SAE80) gear oil for low ambient temperatures (+5°C and less).

Initial change after 50 operating hours and then every 1000 operating hours after one year latest.

IMPORTANT! When operating in damp places or with high temperature fluctuations. Oil must be changed immediately, should condensate (frothy oil) occur in the gear box.

IMPORTANT! If the pump is mounted on a vehicle (possibility of unevenness) and/or if the pump speed is between 300 rpm and 500 rpm, the oil quantity is 1.85 gallons (7.0 L). To check, put the oil dipstick in the bore situated beside the eye bolt.

Keep NPSH under control.

Maximum input pressure 145 PSI (10 bar), maximum suction head -4.35 PSI (-0.3 bar). Make sure that suction pulsation is sufficiently dampened – water column resonance must be avoided.

Safety Rules

Pump operation without safety valve as well as any excess in temperature or speed limits automatically voids the warranty. The safety valve must be regulated in accordance with the guidelines for liquid spraying units so that the admissible operating pressure can not be exceeded by more than 10%.

When the pump is in operation, the open shaft end must be covered up by shaft protector (21), the driven shaft side and coupling by a contact-protector and the plunger room by cover (30).

Pressure in discharge line and in pump must be at zero before any maintenance to the pump takes place. Close up suction line. Disconnect fuses to ensure that the driving motor does not get switched on accidentally.

Make sure that all parts on the pressure side of the unit are vented and refilled, with pressure at zero, before starting the pump.

In order to prevent air, or an air/water-mixture being absorbed and to prevent cavitation occurring, the pump-npshr, positive suction head and water temperature must be kept under control.

Cavitation and/or compression of gases lead to uncontrollable pressure-kicks which can ruin pump and unit parts and also be dangerous to the operator or anyone standing nearby.

Giant Plunger Pumps are suitable for pumping clean water and other non-aggressive or abrasive media with a specific weight similar to water.

Before pumping other liquids - especially inflammable, explosive and toxic media - the pump manufacturer must under all circumstances be consulted with regard to the resistance of the pump material. It is the responsibility of the equipment manufacture and/or operator to ensure that all pertinent safety regulations are adhered to.

NOTE: Contact Giant Industries for Service School Information. Phone: (419)-531-4600.

Specifications - Model GP7150-4000

	U.S.	Metric
Volume.....	54.5 GPM	205.8 LPM
Discharge Pressure.....	1900 PSI	130 Bar
Power Required.....	70.6 HP	52.7 kW
Crankshaft Speed.....		700 RPM
Inlet Pressure.....	-4.35 to 145 PSI	-0.3 to 10 bar
Plunger Diameter.....	1.97"	50mm
Plunger Stroke.....	2.05"	52mm
Crankshaft Diameter.....	1.89"	48mm
Key Width.....	0.55"	14mm
Crankshaft Mounting.....		Either side
Shaft Rotation.....		Top of pulley towards manifold
Max. Temperature of Pumped Fluids.....	140 °F	60 °C
Inlet Ports.....		(2) 2-1/2" BSP
Discharge Ports.....		(2) 1-1/4" BSP
Weight.....	474 lbs	215 kg
Crankcase Oil Capacity.....	1.6 Gal.	6.0 liters
NPSHR.....	31.8 ft. of head	9.7 m. of head

Consult the factory for special requirements that must be met if the pump is to operate beyond one or more of the limits specified above.

PULLEY INFORMATION

Pulley selection and pump speed are based on a 1725 RPM motor and "B" section belts. When selecting desired GPM, allow for a ±5% tolerance on pumps output due to variations in pulleys, belts and motors among manufacturers.

1. Select GPM required, then select appropriate motor and pump pulley from the same line.
2. The desired pressure is achieved by selecting the correct nozzle size that corresponds with the pump GPM.

HORSEPOWER INFORMATION

Horsepower ratings shown are the power requirements for the pump. Gas engine power outputs must be approximately twice the pump power requirements shown above.

We recommend that a 1.15 service factor be specified when selecting an electric motor as the power source. To compute specific pump horsepower requirements, use the following formula:

$$(GPM \times PSI) / 1450 = HP$$

GP7150-4000 Horsepower Requirements					
RPM	GPM	750 PSI	1000 PSI	1500 PSI	1900 PSI
350	27.3	14.1	18.8	28.2	35.8
400	31.1	16.1	21.5	32.2	40.8
500	38.9	20.1	26.8	40.2	51.0
600	46.7	24.2	32.2	48.3	61.2
700	54.5	28.2	37.6	56.4	71.4

Exploded View - GP7150-4000

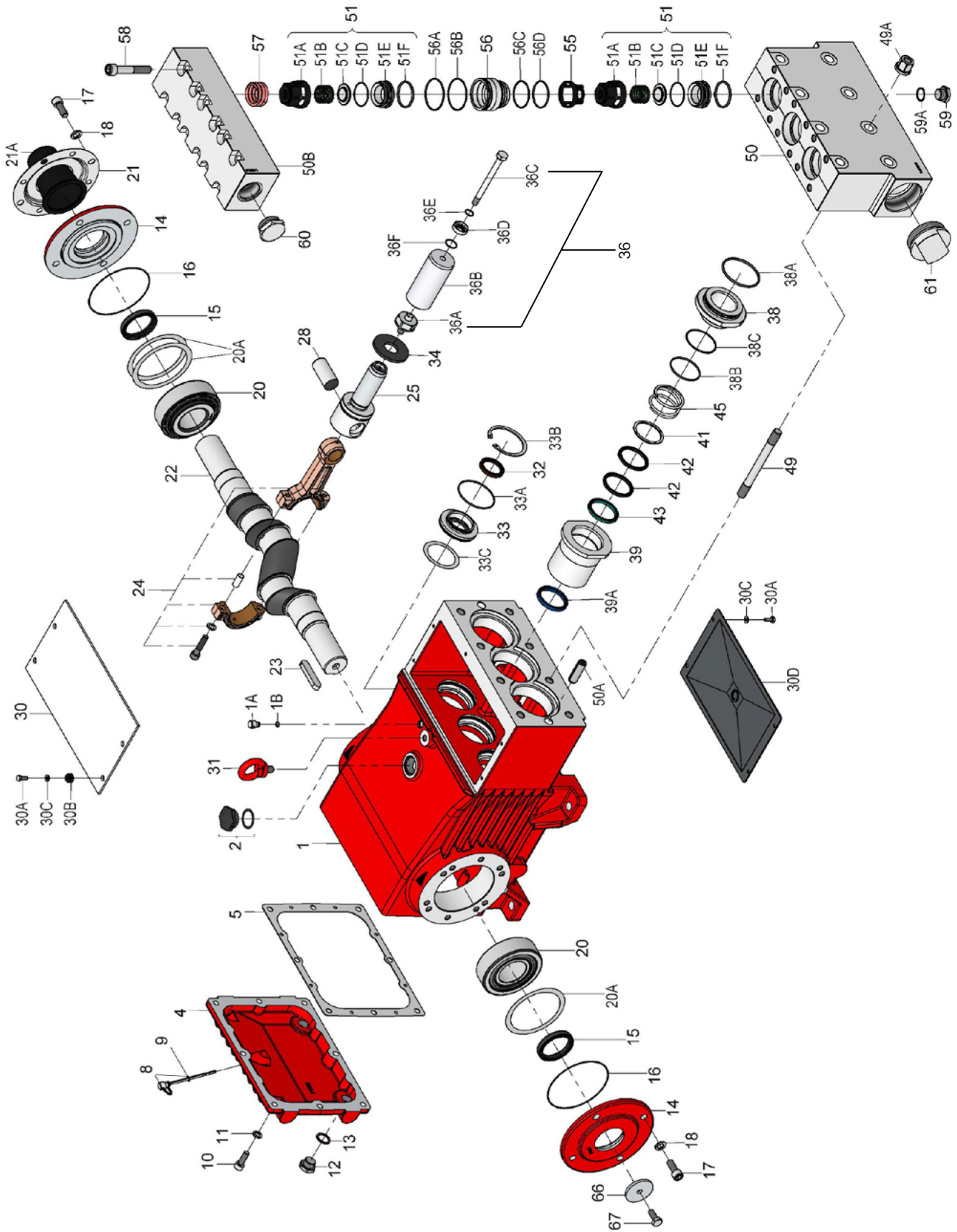

Spare Parts List - GP7150-4000

<u>ITEM</u>	<u>PART</u>	<u>DESCRIPTION</u>	<u>QTY.</u>	<u>ITEM</u>	<u>PART</u>	<u>DESCRIPTION</u>	<u>QTY.</u>
1	07600	Crankcase	1	36C	07664	Tension Screw	3
1A	05525	Head for Oil Dipstick	1	36D	03435	Steel Ring	3
1B	01009	O-Ring	1	36E	05871-0001	O-Ring	3
2	13000	Oil Filler Plug Assembly	1	36F	06015-0001	O-Ring	3
4	07601	Crankcase Cover	1	38	07794	Seal Case	3
5	05798	Gasket, Crankcase Cover	1	38A	13156	O-Ring	3
8	07603	Oil Dip Stick Assembly	1	38B	06258	O-Ring	3
9	01009	O-Ring, Dip Stick	1	38C	07635	Support Ring	3
10	22706	Hexagon Screw	8	39	07795	Seal Sleeve	3
11	06725	Spring Washer	8	39A	07796	Grooved Ring	3
12	07109-0400	Drain Plug	2	41	05318	Sleeve Support Ring	3
13	06272	Gasket, Drain Plug	2	42	07638	Sleeve	6
14	05644	Bearing Cover	2	43	07639-0100	Pressure Ring	3
15	07608	Radial Shaft Seal	2	49	13159	Stud Bolt	8
16	07184	O-Ring	2	49A	06958	Hex Nut	8
17	05642	Inner Hexagon Screw	8	50	04782	Valve Casing	1
18	05039	Spring Washer	8	50A	13162	Cylinder Stud	2
20	07610	Taper Roller Bearing	2	50B	04783	Discharge Casing	1
20A	07611	Fitting Disc (Shim)	1-5	51	05594	Valve Assembly (51A-F)	6
21	05641	Holder for Shaft Protector	1	51A	05595	Spring Tension Cap	6
21A	05646	Shaft Protector	1	51B	05450	Valve Spring	6
22	13405	Crankshaft	1	51C	05247	Valve Plate	6
23	07614	Key	1	51D	05596	O-Ring	6
24	13182	Connecting Rod Assembly	3	51E	05597	Valve Seat	6
25	13183	Crosshead Assembly	3	51F	05166	O-Ring	6
28	13184	Crosshead Pin	3	55	05647	Valve Retainer	3
30	07619	Cover Plate	1	56	13167-0100	Valve Adaptor	3
30A	07225-0100	Hexagon Screw	8	56A	07658	O-Ring	3
30B	13136	Grommet	4	56B	07635	Support Ring for 56A	3
30C	05053	Washer	8	56C	13166	Support Ring for 56D	3
30D	13154	Cover Plate	1	56D	07653	O-Ring	3
31	07623	Eye Bolt	1	57	13173	Tension Spring	3
32	07624	Radial Shaft Seal	3	58	05223	Hexagon Screw	12
33	06950	Seal Retainer	3	59	07109-0400	Plug, 1/2" BSP	2
33A	07627	O-Ring	3	59A	06807	Steel Ring	2
33B	06951	Circlip	3	60	13151	Plug, 1-1/4" BSP	1
33C	07249	Fitting Disc	3	61	12568	Plug, 2-1/2" BSP	1
34	13137	Oil Scraper	3	66	13362	Disc For Crankshaft	1
36	07630-0400	Plunger Pipe Assy. (36A-F)	3	67	13358	Hexagon Screw	1
36A	07667	Plunger Connection	3		07662	Valve Removal Tool	1
36B	07793	Plunger Pipe	3			(not shown)	

Plunger Packing Kit - # 09855

<u>Item</u>	<u>Part #</u>	<u>Description</u>	<u>Qty.</u>
38A	13156	O-Ring	3
38B	06258	O-Ring	3
38C	07635	Support Ring	3
42	07638	Sleeve	6
43	07639-0100	Pressure Ring	3

Valve Kit - # 09856

<u>Item</u>	<u>Part #</u>	<u>Description</u>	<u>Qty.</u>
51	05594	Valve Assembly	6
56A	07658	O-Ring	3
56B	07635	Support Ring	3
56C	13166	Support Ring	3
56D	07653	O-Ring	3

Oil Seal Kit - # 09221

<u>Item</u>	<u>Part #</u>	<u>Description</u>	<u>Qty.</u>
32	07624	Radial Shaft Seal	3
33A	07627	O-Ring	3

GP7150-4000 REPAIR INSTRUCTIONS

To Check Valves

Unscrew hexagon screws (58), remove discharge casing (50B).

Take out tension spring (57), remove the complete valve assembly (51) with either a valve tool (07662) or an M16 hexagon screw. Remove valve adaptor (56) with pull-out tool size 5.

To dismantle valves: screw valve seat (51E) out of spring tension cap (51A). Check sealing surfaces and replace worn parts. Check O-rings and support rings.

Tighten hexagon screw (58) at 103 ft.-lbs. (140 Nm).

To Check Seals and Plunger Pipe

Unscrew nuts (49A) and remove pump head (50, 50B).

Remove cover plate (30).

Separate plunger connection (36A) from crosshead (25) by means of an open-end wrench (size 36 mm).

Pull seal sleeves (39) out of their fittings in the crankcase (1).

Take seal case (38) out of seal sleeve (39). Examine plunger parts (36A-36F), seals (42, 39A) and o-rings.

Replace worn parts.

When replacing plunger pipe (36B), tighten tension screws (36C) to 30 ft.-lbs. (40 Nm).

Grease seals with silicon before installing.

IMPORTANT! Don't loosen the 3 plungers connections (36A) before the valve casing (50) has been removed otherwise the tension screw (36C) could hit against the spring tension cap (51A) when the pump is being turned.

GP7150-4000 seal life can be increased if the pretensioning allows for a little leakage. This assists lubrication and keeps the seals cool. It is therefore not necessary to replace seals before the leakage becomes too heavy and causes output and operating pressure to drop. When reassembling, tighten plunger screws (36A) to 33 ft.-lbs. (45 Nm).

Mounting Valve Casing

Check o-rings (38A, 38B) on seal case (38).

Clean surfaces of seal sleeves (39) in gear box and sealing surfaces of valve casing (50).

Push valve casing carefully onto o-rings of seal case and centring studs (50A). Tighten nuts (49A) to 133 ft.-lbs. (180 Nm).

To Dismantle Gear

Take out plunger (36) and seal sleeves (39) as described above.

Drain oil.

After removing the circlip ring (33B), pry out seal retainer (33) with a screw driver. Check seals (32,33A) and surfaces of crosshead. Possible axial float of the seal adaptor (33) to be compensated with shims (33C).

Remove crankcase cover (4). Loosen screws on the connecting rods (24).

IMPORTANT! Connecting rods (24) are marked for identification. Do not twist connectin rod halves.

Connecting rod is to be reinstalled in the same position on shaft journals.

Push connecting rod halves together with the crosshead (25) as far as possible in to the crosshead guide.

Take out bearing cover (14) to one side and push out crankshaft (22) taking particular care that the connecting rod doesn't bend.

Check surfaces of connecting rod and crankshaft (22).

Reassemble in reverse order: Mount seal (5) with Loctite 5910. Regulate axial play of the crankshaft clearance to minimum 0.1mm, maximum 0.15mm - by means of fitting disc (20A). Shaft should turn easily with little clearance.

Tighten screws (24) to 30 ft.-lbs. (40 Nm).

IMPORTANT! Connecting rod has to be able to be slightly moved sidewise at the stroke journals.

Preventative Maintenance Check-List & Recommended Spare Part List						
Check	Daily	Weekly	50 hrs	Every 500 hrs	Every 1500 hrs	Every 3000hrs
Oil Level / Quality	X					
Oil Leaks	X					
Water Leaks	X					
Belts, Pulley		X				
Plumbing		X				
	Recommended Spare Parts					
Oil Change (p/n 01154)			X	X		
Plunger Packing Kits(1 kit/pump) See page 5 for kit list					X	
Oil Seal Kit (1 kit/Pump) See page 5 for kit list					X	
Valve Assembly Kit (1 kit/pump) See page 5 for kit list						X

Torque Specifications - GP7150-4000

Item #	Part #	Description	Lubrication	U.S. (Metric)
5	05798	Gasket, Crankcase Cover	Loctite 5910	
10	22706	Hexagon Screw		33 ft.-lbs. (45 Nm)
12	07109-0400	Drain Plug		59 ft.-lbs. (80 Nm)
17	05642	Inner Hexagon Screw		33 ft.-lbs. (45 Nm)
24	13182	Connecting Rod Assembly		30 ft.-lbs. (40 Nm)
30A	07225-0100	Hexagon Screw		88.5 in.-lbs. (10 Nm)
32	07624	Radial Shaft Seal	Loctite 403	
36A	07667	Plunger Connection		33 ft.-lbs. (45 Nm)
36C	07664	Tension Screw	Loctite 243	30 ft.-lbs. (40 Nm)
36D	03435	Steel Ring	Loctite 577 (both sides)	
39	07795	Seal Sleeve	Cu-Paste Crankcase side	
49	13159	Stud Bolt	Loctite 648 Crankcase side	
49A	06958	Hex Nut		133 ft.-lbs. (180 Nm)
58	05223	Hexagon Screw	Anti Seize 350	103 ft.-lbs. (140 Nm)

Dimensions - GP7150-4000 - Inches (mm)

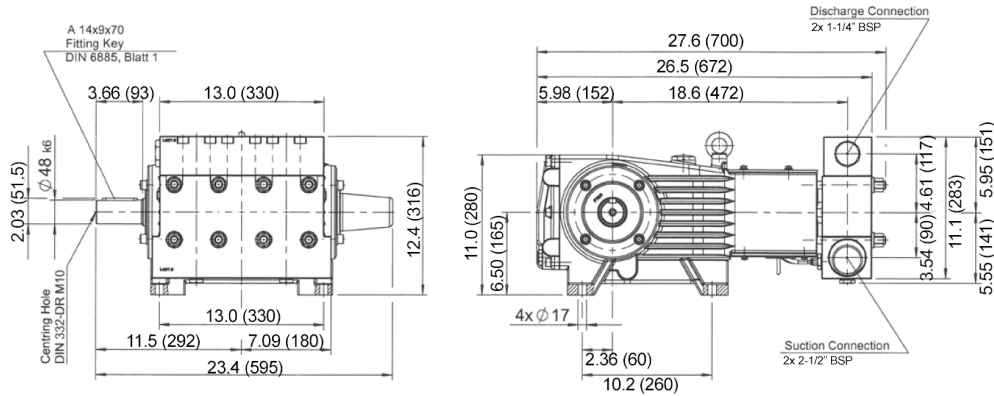

GIANT INDUSTRIES LIMITED WARRANTY

Giant Industries, Inc. pumps and accessories are warranted by the manufacturer to be free from defects in workmanship and material as follows:

1. Five (5) years from the date of shipment for all pumps used in portable pressure washers with NON-SALINE, clean water applications.
2. Two (2) years from the date of shipment for Giant pumps used in car wash applications.
3. One (1) year from the date of shipment for all other Giant industrial and consumer pumps.
4. Six (6) months from the date of shipment for all rebuilt pumps
5. Ninety (90) days from the date of shipment for all Giant accessories.

This warranty is limited to repair or replacement of pumps and accessories of which the manufacturer's evaluation shows were defective at the time of shipment by the manufacturer. The following items are NOT covered or will void the warranty:

1. Defects caused by negligence or fault of the buyer or third party.
2. Normal wear and tear to standard wear parts.
3. Use of repair parts other than those manufactured or authorized by Giant.
4. Improper use of the product as a component part.
5. Changes or modifications made by the customer or third party.
6. The operation of pumps and or accessories exceeding the specifications set forth in the Operations Manuals provided by Giant Industries, Inc.

Liability under this warranty is on all non-wear parts and limited to the replacement or repair of those products returned freight prepaid to Giant Industries which are deemed to be defective due to workmanship or failure of material. A Returned Goods Authorization (R.G.A.) number and completed warranty evaluation form is required prior to the return to Giant Industries of all products under warranty consideration. Call (419)-531-4600 or fax (419)-531-6836 to obtain an R.G.A. number.

Repair or replacement of defective products as provided is the sole and exclusive remedy provided hereunder and the MANUFACTURER SHALL NOT BE LIABLE FOR FURTHER LOSS, DAMAGES, OR EXPENSES, INCLUDING INCIDENTAL AND CONSEQUENTIAL DAMAGES DIRECTLY OR INDIRECTLY ARISING FROM THE SALE OR USE OF THIS PRODUCT.

THE LIMITED WARRANTY SET FORTH HEREIN IS IN LIEU OF ALL OTHER WARRANTIES OR REPRESENTATION, EXPRESS OR IMPLIED, INCLUDING WITHOUT LIMITATION ANY WARRANTIES OR MERCHANTABILITY OR FITNESS FOR A PARTICULAR PURPOSE AND ALL SUCH WARRANTIES ARE HEREBY DISCLAIMED AND EXCLUDED BY THE MANUFACTURER.



WARNING: This product might contain a chemical known to the State of California to cause cancer, and birth defects or other reproductive harm.
For more information go to www.P65Warnings.ca.gov

GIANT
Performance Under Pressure

GIANT INDUSTRIES, INC., 900 N. Westwood Ave., Toledo, Ohio 43607
PHONE (419) 531-4600, FAX (419) 531-6836, www.giantpumps.com
© Copyright 2022 Giant Industries, Inc.