

Models

GP6140-4000 & GP6145-4000

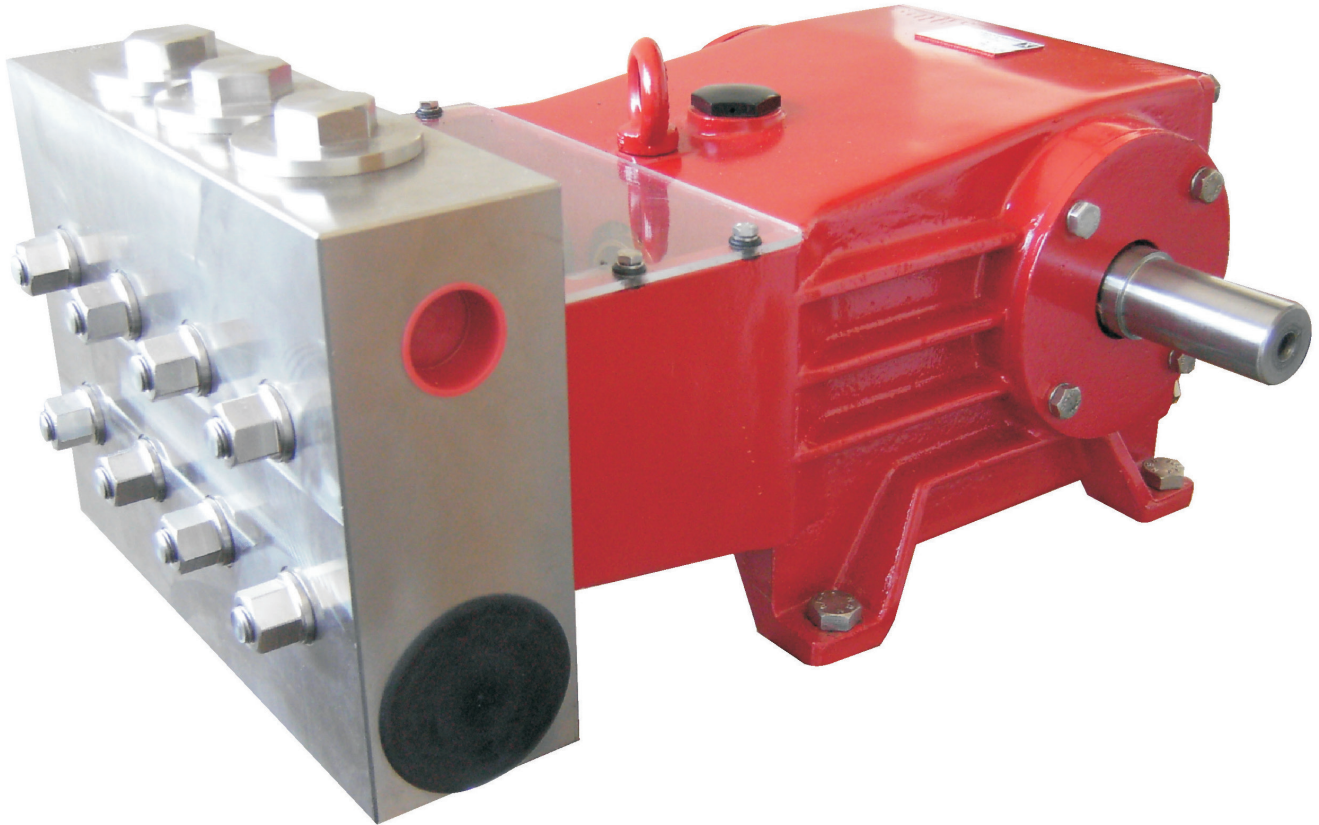

GIANT

Contents:

Installation Instructions:	page 2
Pump Specs.(GP6140-4000):	page 3
Exploded View:	page 4
Parts List / Kits:	page 5
Pump Specs.(GP6145-4000):	page 6
Repair Instructions:	page 7
Torque Specifications:	page 7
Dimensions:	back page
Warranty Information:	back page

INSTALLATION INSTRUCTIONS

Installation of the Giant Industries, Inc., pump is not a complicated procedure, but there are some basic steps common to all pumps. The following information is to be considered as a general outline for installation. If you have unique requirements, please contact Giant Industries, Inc. or your local distributor for assistance.

1. The pump should be installed flat on a base to a maximum of a 15 degree angle of inclination to ensure optimum lubrication.
2. The inlet to the pump should be sized for the flow rate of the pump with no unnecessary restrictions that can cause cavitation. Teflon tape should be used to seal all joints. If pumps are to be operated at temperatures in excess of 140° F, it is important to insure a positive head to the pump to prevent cavitation.
3. The discharge plumbing from the pump should be properly sized to the flow rate to prevent line pressure loss to the work area. It is essential to provide a safety bypass valve between the pump and the work area to protect the pump from pressure spikes in the event of a blockage or the use of a shut-off gun.

4. Use of a dampener is necessary to minimize pulsation at drive elements, plumbing, connections, and other system areas. The use of a dampener with Giant Industries, Inc. pumps is optional, although recommended by Giant Industries, Inc. to further reduce system pulsation. Dampeners can also reduce the severity of pressure spikes that occur in systems using a shut-off gun. A dampener must be positioned downstream from the unloader.

5. Crankshaft rotation on Giant Industries, Inc. pumps should be made in the direction designated by the arrows on the pump crankcase. Reverse rotation may be safely achieved by following a few guidelines available upon request from Giant Industries, Inc. Required horsepower for system operation can be obtained from the charts on pages 3 and 6.

6. Before beginning operation of your pumping system, remember: Check that the crankcase and seal areas have been properly lubricated per recommended schedules. Do not run the pump dry for extended periods of time. Cavitation will result in severe damage. Always remember to check that all plumbing valves are open and that pumped media can flow freely to the inlet of the pump.

Finally, remember that high pressure operation in a pump system has many advantages. But, if it is used carelessly and without regard to its potential hazard, it can cause serious injury.

IMPORTANT OPERATING CONDITIONS

Failure to comply with any of these conditions invalidates the warranty.

1. Prior to initial operation, add oil to the crankcase so that oil level is between the two lines on the oil dipstick. **DO NOT OVERFILL.**

Use Giant Recommended Oil (p/n 01154), which is equivalent to SAE 85-90W Industrial Gear Lube Oil.

Crankcase oil should be changed after the first 50 hours of operation, then at regular intervals of 500 hours or less depending on operating conditions.

NOTE: Contact Giant Industries for Service School Information. Phone: (419)-531-4600

2. Pump operation must not exceed rated pressure, volume, or RPM. A pressure relief device must be installed in the discharge of the system.

3. Acids, alkalines, or abrasive fluids cannot be pumped unless approval in writing is obtained before operation from Giant Industries, Inc.

4. Run the pump dry approximately 10 seconds to drain the water before exposure to freezing temperatures.

Specifications

Model GP6140-4000

Volume.....	36.7 GPM.....	139 L/min
Discharge Pressure	2175 PSI	150 Bar
Speed		800 RPM
Inlet Pressure (max.)	145 PSI	10 Bar
Plunger Diameter.....	1.57".....	40mm
Plunger Stroke.....	1.89".....	48mm
Crankshaft Diameter.....	1.78".....	45mm
Key Width	0.47".....	12mm
Crankshaft Mounting.....		Either side
Shaft Rotation.....		Top of pulley towards manifold
Temperature of Pumped Fluids (max).		140 °F 60 °C
Inlet Ports.....		(2) 2-1/2" BSP
Discharge Ports		(2) 1-1/4" BSP
Weight.....	309 lbs.	140 Kg
Crankcase Oil Capacity	1.1 Gal.	4.2 Liters
Fluid End Material.....		Stainless Steel

Consult the factory for special requirements that must be met if the pump is to operate beyond one or more of the limits specified above.

HORSEPOWER RATINGS:

The rating shown are the power requirements for the pump. Gas engine power outputs must be approximately twice the pump power requirements shown above.

We recommend a 1.15 service factor be specified when selecting an electric motor as the power source. To compute specific pump horsepower requirements, use the following formula:

$$HP = (GPM \times PSI) / 1450$$

GP6140-4000 HORSEPOWER REQUIREMENTS					
RPM	GPM	500 PSI	1000 PSI	1500 PSI	2175 PSI
400	18.4	6.6	13.1	19.7	28.5
500	22.9	8.2	16.4	24.6	35.6
600	27.5	9.8	19.7	29.5	42.8
700	32.1	11.5	22.9	34.4	49.9
800	36.7	13.1	26.2	39.3	57.0

Exploded View - GP6140-4000 & GP6145-4000

Important! The stainless steel valve plugs (56) can seize when being taken out of the valve casing. To release tension beforehand, strike the plugs 1-2 times with a steel hammer on the top before removing them. Coat threads with anti-seize (e.g., ProPack 550) before refitting.

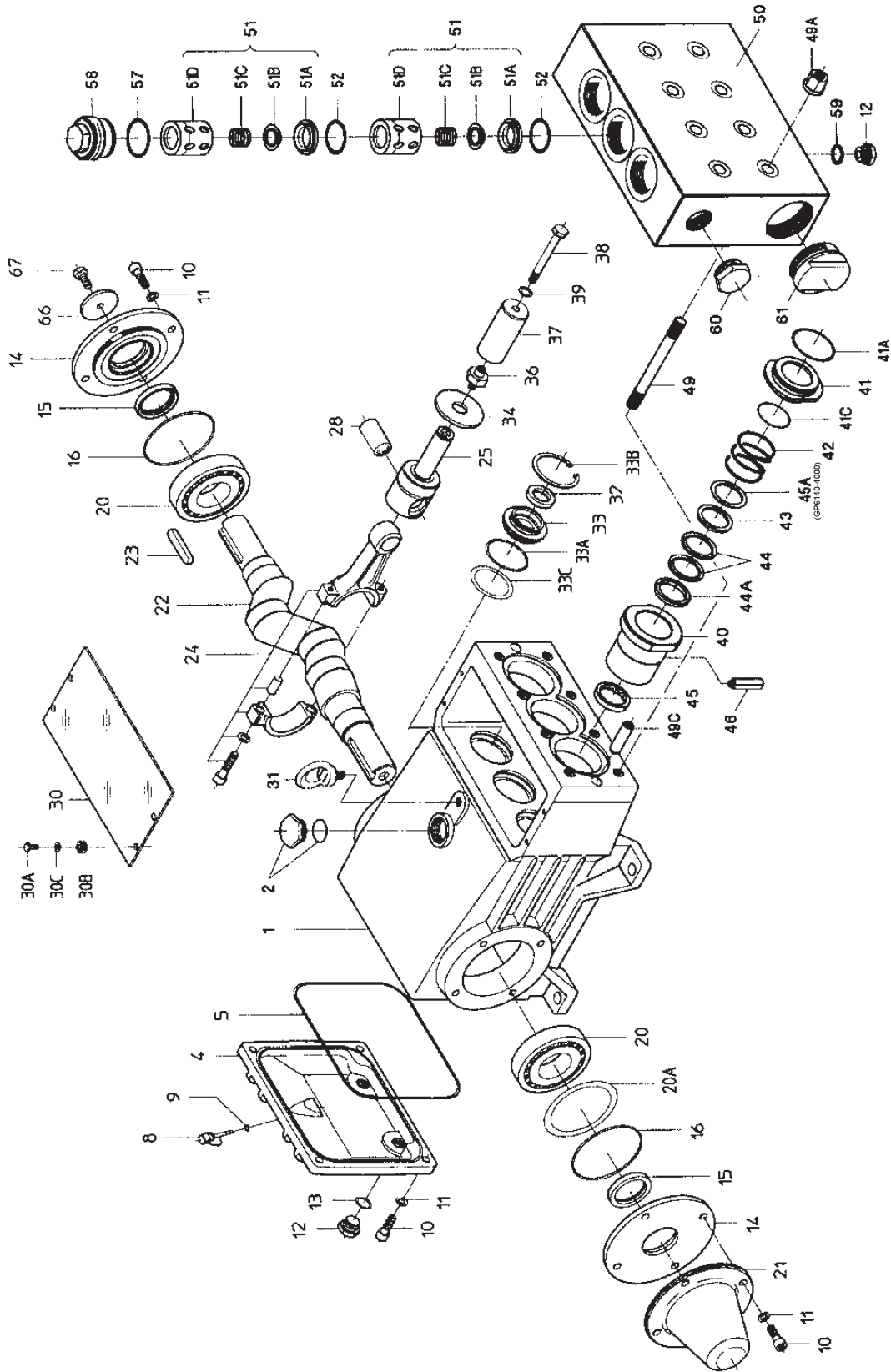

GP6140-4000 & GP6145-4000 PARTS LIST

ITEM	PART	DESCRIPTION	QTY.	ITEM	PART	DESCRIPTION	QTY.
1	13200	Crankcase	1	41C	13141	O-Ring for 41	3
2	13000	Oil Filler Plug Assy	1	41D	07693	Support Ring for 41C	3
4	13201	Crankcase Cover	1	42	13297	Tension Spring	3
5	13202	O-Ring for 4	1	43	12558	Sleeve Support Ring (GP6140-4000)	3
8	06894	Oil Dipstick	1	43	13395	Sleeve Support Ring (GP6145-4000)	3
9	01009	O-Ring for 8	1	44	12559	Sleeve ((GP6140-4000)	6
10	22706	Hexagon Screw	12	44	13294	Sleeve (GP6145-4000)	6
11	06725	Spring Washer	12	44A	12560	Pressure Ring (GP6140-4000)	3
12	07109-0400	Drain Plug	3	44A	13292	Pressure Ring (GP6145-4000)	3
13	07182	Seal for 12	2	45	12561	Leakage Seal (GP6140-4000)	3
14	12549	Bearing Cover	2	45	13290	Leakage Seal (GP6145-4000)	3
15	13205	Radial Shaft Seal	2	45A	12562	Spacer Disc (GP6140-4000) only	3
16	08055	O-Ring for 14	2	46	05169	Threaded Pipe	3
20	13206	Taper Roller Bearing	2	49	13159	Stud Bolt	8
20A	13207	Fitting Disc	1-5	49A	06958	Hexagon Nut	8
21	13208	Shaft Protector	1	49C	13162	Centring Stud	2
22	06895	Crankshaft	1	50	12563	Valve Casing	1
23	08213	Fitting Key	1	51	05164	Valve Assembly (51A-D)	6
24	06896	Connecting Rod Assy	3	51A	12564	Valve Seat	6
25	12550	Crosshead Assy	3	51B	12565	Valve Plate	6
28	06898	Crosshead Pin	3	51C	12566	Valve Spring	6
30	13214	Cover Plate	1	51D	12567	Spacer Pipe	6
30A	07225-0100	Hexagon Screw	4	52	05166	O-Ring for 51	6
30B	13136	Grommet	4	56	05171	Plug	3
30C	08280	Disc	4	57	05167	O-Ring for 56	3
31	07623	Eye Bolt	1	59	06807	Copper Seal for 12	1
32	06118	Radial Shaft Seal	3	60	13151	Plug G 1 1/4	1
32A	13216	Grooved Ring	3	61	12568	Plug G 2 1/2	1
33	13216-0100	Seal Retainer	3	66	13362	Disc for Crankshaft	1
33A	07721	O-Ring for 33	3	67	13358	Hexagon Screw	1
33B	13217-0100	Circlip for 33	3		17245	Gear Assembly (2x12/1-34/49/49A-C/66/67)	1
33C	12551	Fitting Disc	3		17746	Pump Head Assembly (3x12/50-61)	1
34	13218	Oil Scraper	3		17247	Plunger Replacement Kit (GP6140-4000)	1
36	12552	Plunger Connection	3		17248	Plunger Replacement Kit (GP6140-4000)	1
36A	07125	Centering Sleeve	3				
37	12553	Plunger Pipe (GP6140-4000)	3				
37	05157	Plunger Pipe (GP6145-4000)	3				
38	12554	Tensioning Screw	3				
39	07755-0100	Copper Ring	3				
40	12555	Seal Sleeve (GP6140-4000)	3				
40	12556	Seal Sleeve (GP6145-4000)	3				
41	12557	Seal Case	3				
41A	07721	O-Ring for 41	3				
41B	13223	Support Ring for 41A	3				

GP6140-4000 & GP6145-4000 REPAIR KITS

Plunger Packing Kits

GP 6140-4000		# 09622	
Item	Part #	Description	Qty.
41A	07721	O-Ring	3
41C	13141	O-Rin	3
44	12559	Sleeve	6
44A	12560	Pressure Ring	3
45	12561	Grooved Ring	3
GP6145-4000		# 09623	
Item	Part #	Description	Qty.
41A	07721	O-Ring	3
41C	13141	O-Rin	3
44	13294	Sleeve	6
44A	13292	Pressure Ring	3
45	12561	Grooved Ring	3

Valve Assembly Kit - #09624

Item	Part #	Description	Qty.
51A	12564	Valve Seat	6
51B	12565	Valve Plate	6
51C	12566	Valve Spring	6
52	05166	O-Ring	6
57	05167	O-Ring	6

Oil Seal Kit - 09625

Item	Part #	Description	Qty.
32	06118	Radial Shaft Seal	3
33A	07721	O-Ring	3

Specifications

Model GP6145-4000

Volume.....	46.5 GPM.....	175.9 L/min
Discharge Pressure	1740 PSI	120 Bar
Speed		800 RPM
Inlet Pressure (max.)	145 PSI	10 Bar
Plunger Diameter.....	1.77".....	45mm
Plunger Stroke.....	1.89".....	48mm
Crankshaft Diameter.....	1.78".....	45mm
Key Width	0.47".....	12mm
Crankshaft Mounting.....		Either side
Shaft Rotation.....		Top of pulley towards manifold
Temperature of Pumped Fluids (max).		140 °F 60 °C
Inlet Ports.....		(2) 2-1/2" BSP
Discharge Ports		(2) 1-1/4" BSP
Weight.....	309 lbs.	140 Kg
Crankcase Oil Capacity	1.1 Gal.	4.2 Liters
Fluid End Material.....		Stainless Steel

Consult the factory for special requirements that must be met if the pump is to operate beyond one or more of the limits specified above.

HORSEPOWER RATINGS:

The rating shown are the power requirements for the pump. Gas engine power outputs must be approximately twice the pump power requirements shown above.

We recommend a 1.15 service factor be specified when selecting an electric motor as the power source. To compute specific pump horsepower requirements, use the following formula:

$$HP = (GPM \times PSI) / 1450$$

GP6145-4000 HORSEPOWER REQUIREMENTS					
RPM	GPM	500 PSI	1000 PSI	1500 PSI	1740 PSI
400	23.3	8.3	16.6	24.9	28.9
500	29.1	10.4	20.8	31.1	36.1
600	34.9	12.5	24.9	37.4	43.3
700	40.7	14.5	29.1	43.6	50.6
800	46.5	16.6	33.2	49.8	57.8

GP6140-4000 & GP6145-4000 REPAIR INSTRUCTIONS

To Check Valves

Loosen plugs (56) and take out complete valve (51) with a slide hammer (provided with pump). With a bent piece of wire, take out o-rings (52) located between the suction and discharge valves. To dismantle the valves, carefully tap the valve plate (51B) with a bolt until the valve seat (51A) is pushed out of the spacer pipe (51D). Check the sealing surfaces and replace all worn parts. Check the o-rings. When reinstalling the valve, particular care must be taken so that the o-rings sit properly in their fittings in the valve casing. Tighten the plugs (56) to 160 ft.-lbs..

To Check Seals and Plunger Pipe

Loosen nuts (49A) and remove the pump head. Separate the plunger connection (36) from the crosshead assembly (25) by means of two open-end wrenches (size 22mm and 27mm). Pull seal sleeves (40) out of their fittings in the crankcase (1). Take seal case (41) out of seal sleeve (40). Examine plunger (37) and sleeves (and grooved ring (45A) in GP6140-4000 only). Check the o-rings (41A and 41C). Replace worn parts. Grease seals with Silicone before reinstalling. Replace plunger (37) and tighten to 355 in.-lbs.

IMPORTANT: Do not loosen the three plunger screws (36) before the valve casing (50) has been removed; otherwise, the tension screw (38) could hit against the spacer pipe (51D) when the pump is being turned.

For the pumps, the seal unit (43, 44, 44A) is loaded by a spring (42). Seal life can be increased if the loading allows for a little leakage. This assists lubrication and keeps the seals cool. It is therefore not necessary to replace the seals before the leakage becomes too heavy and causes output and operating pressure to drop. When reassembling, tighten plunger (37) to 33 ft.-lbs.

Check o-rings on seal case (41). Clean surfaces of seal sleeves in gear box and sealing surfaces of valve casing. Push valve casing carefully onto o-rings of seal case and centering studs (49C). Tighten nuts (49A) to 103 ft.-lbs.

To Disassemble Gear End

Take out plunger and seal sleeves as described above. Drain oil. After removing the circlip ring (33B), pry out seal retainer (33) with a screw driver. Check seals (32 and 33A) and surfaces of crosshead. Remove crankcase cover (4). Loosen inner hexagon screws on the connecting rods (24) and push connecting rod halves as far into the crosshead guide as possible.

IMPORTANT: Connecting rods are marked for identification. Do not twist con rod halves. Con rod is to be reinstalled in the same position on shaft journals. Check surfaces of connecting rod and crankshaft (22). Take out bearing cover to one side and push out crankshaft taking particular care that the connecting rod does not get bent.

Reassemble in reverse order: Regulate axial bearing clearance - minimum 0.1mm, maximum 0.15mm - by means of fitting disc (20A). Shaft should turn easily with little clearance. Tighten inner hexagon screws (24) to 355 in.-lbs.

IMPORTANT: Connecting rod has to be able to be slightly moved sidewise at the stroke journals.

GP6140-4000 and GP6145-4000 TORQUE SPECIFICATIONS

<u>Position</u>	<u>Item#</u>	<u>Description</u>	<u>Torque Amount</u>
24	06896	Inner Hexagon Screw	355 in.-lbs.
38	12554	Tensioning Screw	33 ft.-lbs.
49A	06958	Nut, Valve Casing	103 ft.-lbs.
56	05171	Tensioning Plug	160 ft.-lbs.

GP6140-4000 & GP6145-4000 DIMENSIONS - Inches (mm)

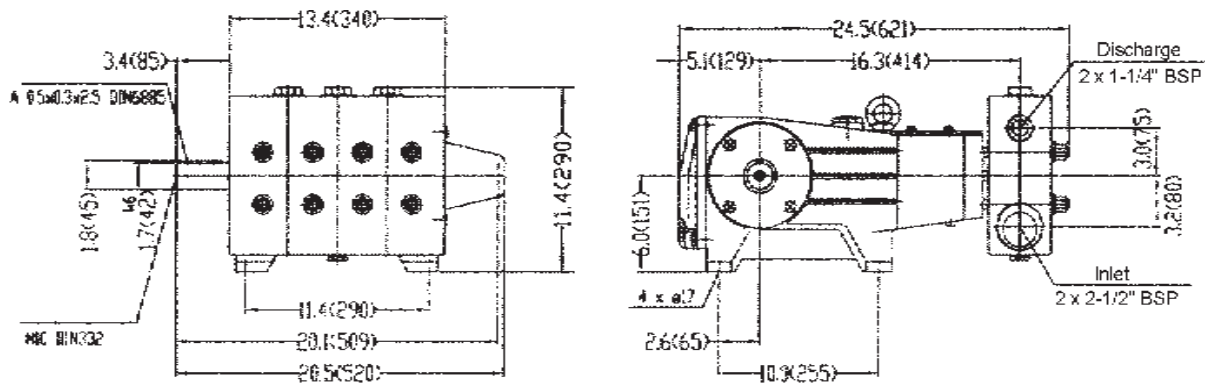

GIANT INDUSTRIES LIMITED WARRANTY

Giant Industries, Inc. pumps and accessories are warranted by the manufacturer to be free from defects in workmanship and material as follows:

1. Five (5) years from the date of shipment for all pumps used in portable pressure washers with NON-SALINE, clean water applications.
2. Two (2) years from the date of shipment for Giant pumps used in car wash applications.
3. One (1) year from the date of shipment for all other Giant industrial and consumer pumps.
4. Six (6) months from the date of shipment for all rebuilt pumps
5. Ninety (90) days from the date of shipment for all Giant accessories.

This warranty is limited to repair or replacement of pumps and accessories of which the manufacturer's evaluation shows were defective at the time of shipment by the manufacturer. The following items are NOT covered or will void the warranty:

1. Defects caused by negligence or fault of the buyer or third party.
2. Normal wear and tear to standard wear parts.
3. Use of repair parts other than those manufactured or authorized by Giant.
4. Improper use of the product as a component part.
5. Changes or modifications made by the customer or third party.
6. The operation of pumps and or accessories exceeding the specifications set forth in the Operations Manuals provided by Giant Industries, Inc.

Liability under this warranty is on all non-wear parts and limited to the replacement or repair of those products returned freight prepaid to Giant Industries which are deemed to be defective due to workmanship or failure of material. A Returned Goods Authorization (R.G.A.) number and completed warranty evaluation form is required prior to the return to Giant Industries of all products under warranty consideration. Call (419)-531-4600 or fax (419)-531-6836 to obtain an R.G.A. number.

Repair or replacement of defective products as provided is the sole and exclusive remedy provided hereunder and the MANUFACTURER SHALL NOT BE LIABLE FOR FURTHER LOSS, DAMAGES, OR EXPENSES, INCLUDING INCIDENTAL AND CONSEQUENTIAL DAMAGES DIRECTLY OR INDIRECTLY ARISING FROM THE SALE OR USE OF THIS PRODUCT.

THE LIMITED WARRANTY SET FORTH HEREIN IS IN LIEU OF ALL OTHER WARRANTIES OR REPRESENTATION, EXPRESS OR IMPLIED, INCLUDING WITHOUT LIMITATION ANY WARRANTIES OR MERCHANTABILITY OR FITNESS FOR A PARTICULAR PURPOSE AND ALL SUCH WARRANTIES ARE HEREBY DISCLAIMED AND EXCLUDED BY THE MANUFACTURER.



WARNING: This product might contain a chemical known to the State of California to cause cancer, and birth defects or other reproductive harm.
For more information go to www.P65Warnings.ca.gov

GIANT

GIANT INDUSTRIES, INC., 900 N. Westwood Ave., P.O. Box 3187, Toledo, Ohio 43607
PHONE (419) 531-4600, FAX (419) 531-6836, www.giantpumps.com
© Copyright 2007 Giant Industries, Inc.