

Models

**GP5132, GP5132-SSP,
GP5136, GP5142 & GP5145**

Triplex Ceramic
Plunger Pump
Operating Instructions /
Manual

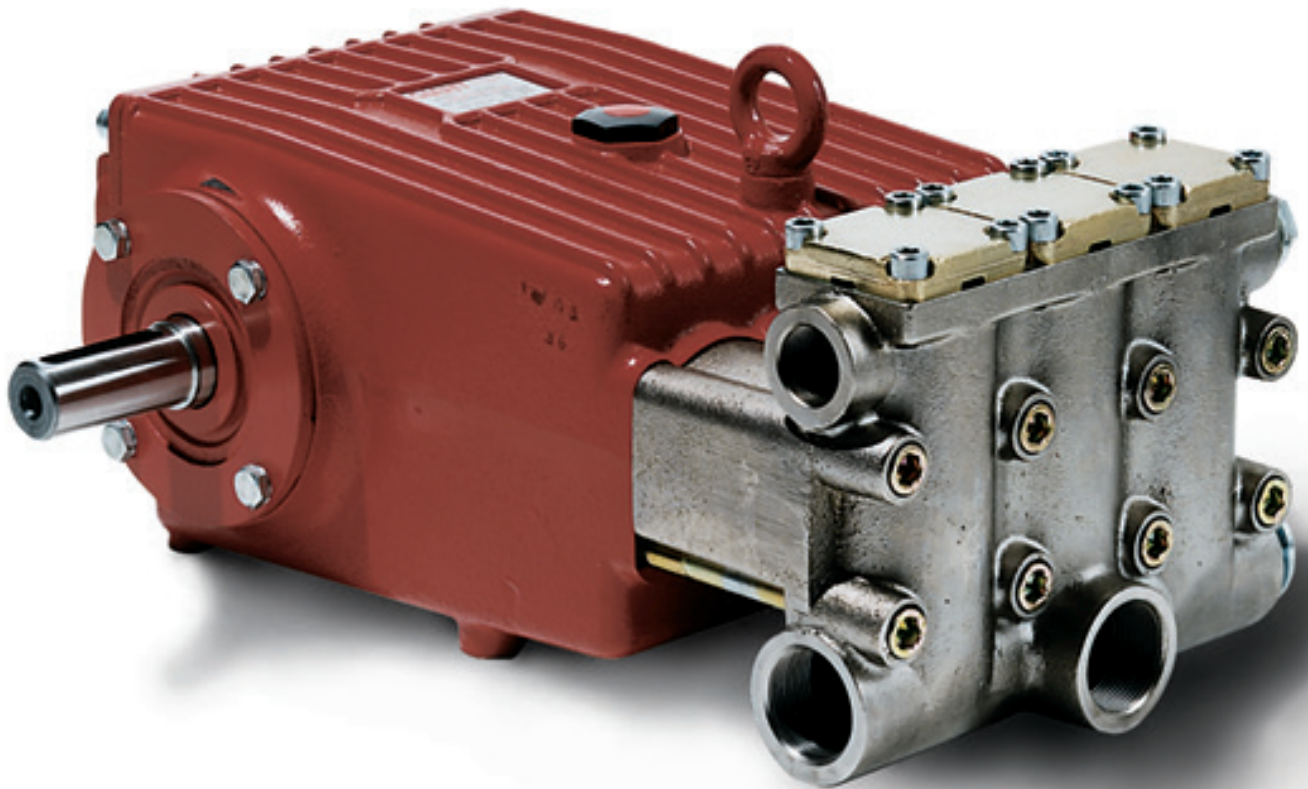

GIANT
Performance Under Pressure

Updated 09/24

Contents:

Installation Instructions:	page 2
Pump Specifications:	page 3
Exploded View:	page 4
Parts List:	page 5
Kits/Torque Specs:	page 6
Repair Instructions:	page 7
Dimensions:	back page
Warranty Information	back page

INSTALLATION INSTRUCTIONS

Figures for speed (rpm) and pressure apply to interval operation with cold water.

For continual operation, the speed of all pump models must be limited to 700 rpm and the max. operating pressure reduced by 10%.

Required NPSH refers to water: Specific weight 1kg/dm³, viscosity 1°E at max. permissible revolutions.

Operation and Maintenance

Check oil level prior to starting and ensure trouble-free water supply. Oil: Use only 1.2 gallons (4.6 liters) of Industrial Gear Lube Oil (Giant p/n 01154) or ISO VG 220 (e.g. Aral Degol BG220) or SAE 90 gear oil.

Initial change after 50 operating hours and then every 500 operating hours.

Caution when operating in damp places or with high temperature fluctuations. Oil must be changed immediately, should condensate (frothy oil) occur in the gear box.

Keep NPSH under control.

Max. input pressure 145 PSI (10 bar), max. suction head -4.35 PSI (-0.3 bar).



Safety Rules

Pump operation without safety valve as well as any excess in temperature or speed limits automatically voids the warranty. The safety valve must be regulated in accordance with the guidelines for liquid spraying units so that the admissible operating pressure can not be exceeded by more than 10%.

When the pump is in operation, the open shaft end must be covered up by a shaft protector (21), the driven shaft side and coupling by a contact-protector.

Pressure in discharge line and in pump must be at zero before any maintenance to the pump takes place. Close up suction line. Disconnect fuses to ensure that the driving motor does not get switched on accidentally.

Make sure that all parts on the pressure side of the unit are vented and refilled, with pressure at zero, before starting the pump.

In order to prevent air, or an air/water-mixture being absorbed and to prevent cavitation occurring, the pump-npshr, positive suction head and water temperature must be kept under control.

Cavitation and/or compression of gases lead to uncontrollable pressure-kicks which can ruin pump and unit parts and also be dangerous to the operator or anyone standing nearby.

Giant plunger pumps are suitable for pumping clean water and other non-aggressive or abrasive media with a specific weight similar to water.

Before pumping other liquids - especially inflammable, explosive and toxic media - the pump manufacturer must under all circumstances be consulted with regard to the resistance of the pump material. It is the responsibility of the equipment manufacturer and/or operator to ensure that all pertinent safety regulations are adhered to.

GP5100 SERIES PUMP SPECIFICATIONS

	Max. Flow	Max. Pressure	Max. Speed	Power Req'd.	Max. Temp.	Plunger Diameter	NPSH Required
Model	GPM	PSI	RPM	HP	F	in	Ft-Head
GP5132	27.7	2900	1000	57	140	1.26	27.9
GP5132*	40	3000	1444	83	140	1.26	27.9
GP5136	33.8	2320	910	56	140	1.42	27.9
GP5142	40.4	1885	800	52.5	140	1.65	N/A
GP5145	43.5	1450	750	45	140	1.77	29.5

* Intermittent duty only.

	Max. Flow	Max. Pressure	Max. Speed	Power Req'd.	Max. Temp.	Plunger Diameter	NPSH Required
Model	L/min	Bar	RPM	kW	C	mm	mWs
GP5132	104.9	200	1000	42.8	60	32	8.5
GP5132*	151.4	207	1444	61.9	60	32	8.5
GP5136	127.8	160	910	41.8	60	36	8.5
GP5142	153.0	130	800	39.2	60	42	N/A
GP5145	164.6	100	750	33.6	60	45	9.0

* Intermittent duty only.

Horsepower Ratings:

We recommend a 1.15 service factor be specified when selecting an electric motor as the power source.

To compute electric motor horsepower required, use the following formula: $HP = (GPM \times PSI) / 1450$.

The formula to determine the horsepower required for a gas engine is: $HP = (GPM \times PSI) / 1150$.

The formula to determine the horsepower required for a diesel engine is: $HP = (GPM \times PSI) / 1250$.

For the Application of a Hydraulic Motor:

To Determine the Torque of a Hydraulic Motor -- $(GPM \times PSI \times 36.77) / RPM = \text{Torque (in-lbs)}$

Calculating RPM / GPM of Pump:

A pump must be connected to an electric motor or gas or diesel engine with the correct ratio of pulleys and belts to attain the required speed and GPM. The use of a Variable Frequency Drive (VFD) may also be used to control the RPM of a properly sized electric motor when variable flows are required.

$$(\text{Max. Pump RPM} / \text{Rated Pump GPM}) \times \text{Required Pump GPM} = \text{Required Pump RPM}$$

To calculate a pulley diameter one (1) pulley diameter and the required pump RPM must be known:

$$(\text{Pump RPM} \times \text{Pump Pulley Diameter}) / \text{Motor RPM} = \text{Motor Pulley Diameter}$$

$$(\text{Motor RPM} \times \text{Motor Pulley Diameter}) / \text{Pump RPM} = \text{Pump Pulley Diameter}$$

Common Specifications:

Inlet Pressure ..-4.35 to 145 PSI (-0.3 to 10 Bar)
 Max. Temperature..... 140 °F (60 °C)
 Crankshaft Diameter..... 1.38" (35mm)
 Crankcase Oil Capacity 1.2 Gal. (4.6 L)
 Inlet Ports(3) 1-1/2" NPT
 Discharge Ports(2) 1" NPT
 Stroke1.81" (46mm)
 Weight 179 lbs (81kg)
 Shaft Rotation..Top of Pulley Toward Fluid End

Materials Used for MP Pumps:

Manifold Nickel-Plated Spheroidal Cast Iron
 Plungers Solid Ceramic Oxide
 Valves Stainless Steel/Plastic Retainer
 Seals..... Nitrile with Fabric Reinforcing
 Gear End Spheroidal Cast Iron

Consult the factory for special requirements that must be met if the pump is to operate beyond one or more of the limits specified above.

EXPLODED VIEW - GP5132, GP5132-SSP, GP5136, GP5142 & GP5145 PUMPS

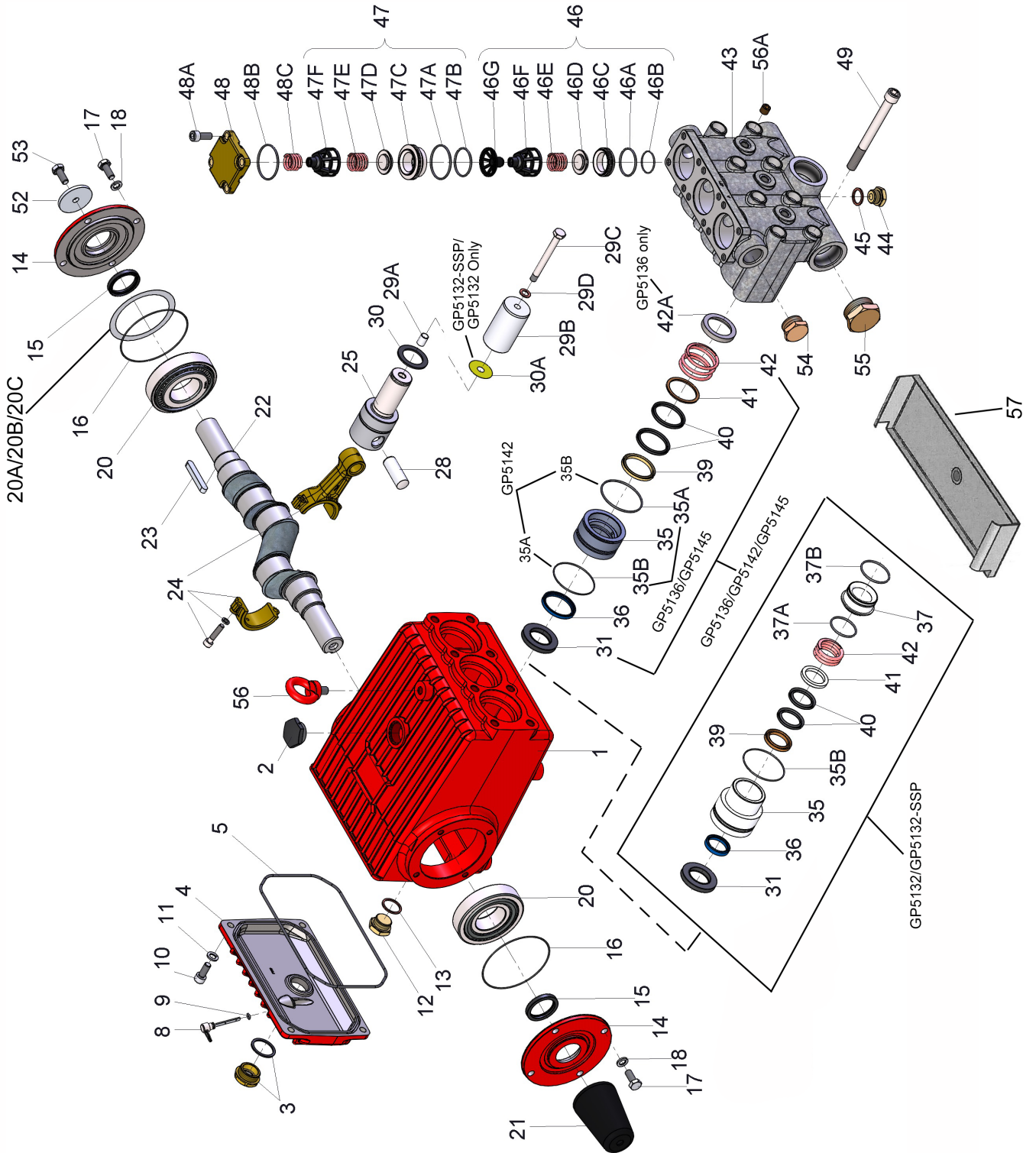

GP5132, GP5132-SSP, GP5136, GP5142 & GP5145 SPARE PARTS LIST

<u>ITEM</u>	<u>PART</u>	<u>DESCRIPTION</u>	<u>QTY.</u>	<u>ITEM</u>	<u>PART</u>	<u>DESCRIPTION</u>	<u>QTY.</u>
1	13266	Crankcase	1	37B	07653	O-Ring (GP5132/-SSP)	3
2	13000	Oil Filler Plug Assembly	1	39	13026	Pressure Ring	
3	05943	Oil Sight Glass Assy.	1			(GP5132/-SSP)	3
4	13267	Crankcase Cover	1	39	07142	Pressure Ring (GP5136)	3
5	13268	O-Ring	1	39	07744	Pressure Ring (GP5142)	3
8	07105	Oil Dip Stick	1	39	13293	Pressure Ring (GP5145)	3
9	01009	O-Ring, Dip Stick	1	40	13027	V-Sleeve (GP5132/-SSP)	6
10	07008	Inner Hexagon Screw	4	40	07144	V-Sleeve (GP5136)	6
11	06725	Spring Washer	4	40	07745	V-Sleeve (GP5142)	6
12	07703	Drain Plug, 3/4" BSP	1	40	13294	V-Sleeve (GP5145)	6
13	07704	Gasket, Drain Plug	1	41	13028	Sleeve Support Ring	
14	13271	Bearing Cover	2			(GP5132/-SSP)	3
15	13272	Radial Shaft Seal	2	41	07146	Sleeve Support Ring	
16	08182	O-Ring	2			(GP5136)	3
17	13358	Hexagon Screw	8	41	07746	Sleeve Support Ring	
18	06725	Spring Washer	8			(GP5142)	3
20	13206	Taper Roller Bearing	2	41	13296	Sleeve Support Ring	
20A	13207	Shim, 0.1mm	1-5			(GP5145)	3
20B	04723	Shim, 0.15mm	1-5	42	07173	Tension Spring	
20C	04724	Shim, 0.2mm	1-5			(GP5132/-SSP)	3
21	13273	Shaft Protector	1	42	07147	Tension Spring (GP5136)	3
22	13274	Crankshaft	1	42	13297	Tension Spring (GP5142)	3
23	13275	Fitting Key	1	42	13297	Tension Spring (GP5145)	3
24	13276	Connecting Rod Assy.	3	42A	13298	Spring Guide	
25	13279	Crosshead Assy.	3			(GP5136 only)	3
28	13281	Crosshead Pin	3	43	13300	Valve Casing	1
29A	07125	Centering Sleeve	3	44	07109	Plug, 1/2" BSP	1
29B	13022	Plunger Pipe (GP5132)	3	45	06272	Copper Washer, 1/2" BSP	1
29B	13022-SS	Plunger Pipe (GP5132-SSP)	3	46	13302	Suction Valve Assy.	3
29B	07130	Plunger Pipe (GP5136)	3	46A	12055	O-Ring	3
29B	07736	Plunger Pipe (GP5142)	3	46B	08059	O-Ring	3
29B	13283	Plunger Pipe (GP5145)	3	46C	13304	Suction Valve Seat	3
29C	13031	Tensioning Screw	3	46D	13306	Valve Plate	3
29D	07755	Copper Ring	3	46E	13307	Valve Spring	3
30	13282	Oil Scraper	3	46F	13308	Spring Tension Cap	3
30A	05889	Washer for Drip Shield		46G	13309	Spacer Pipe	3
		(GP5132/-SSP Only)	3	47	13311	Discharge Valve Assy.	3
31	13284	Radial Shaft Seal	3	47A	13289	O-Ring	3
35	13359	Seal Sleeve (GP5132/-SSP)	3	47B	07700	O-Ring	3
35	13288	Seal Sleeve (GP5136)	3	47C	13314	Discharge Valve Seat	3
35	04325	Seal Sleeve (GP5142)	3	47D	13306	Valve Plate	3
35	13287	Seal Sleeve (GP5145)	3	47E	13307	Valve Spring	3
35A	08183	O-Ring (GP5136)	3	47F	13308	Spring Tension Cap	3
35A	08183	O-Ring (GP5142)	3	48	13316	Plug	3
35A	13286	O-Ring (GP5145)	3	48A	07008	Inner Hexagon Screw	12
35B	08183	O-Ring		48B	07740	O-Ring	3
		(except GP5136/GP5142)	3	48C	07232	Pressure Spring	3
35B	13289	O-Ring (GP5136 only)	3	49	13339	Inner Hexagon Screw	8
35B	13286	O-Ring (GP5142 only)	3	52	13362	Disc for Crankshaft	1
36	13360	Grooved Ring		53	13358	Hexagon Screw	1
		(GP5132/-SSP)	3	54	06626	Plug, 1" NPT	1
36	13291	Grooved Ring (GP5136)	3	55	06627	Plug, 1-1/2" NPT	2
36	04323	Grooved Ring (GP5142)	3	56	07623	Eye Bolt	1
36	13290	Grooved Ring (GP5145)	3	56A	22610	Plug, 1/4" NPT	3
37	13361	Seal Case (GP5132/-SSP)	3	57	04334	Drip Tray	1
37A	07700	O-Ring (GP5132/-SSP)	3				

GP5132, GP5132-SSP, GP5136, GP5142 and GP5145 REPAIR KITS

Plunger Packing Kits

GP5132/GP5132-SSP		#09290	
<u>Item</u>	<u>Part#</u>	<u>Description</u>	<u>Qty.</u>
35B	08183	O-Ring	3
36	13360	Grooved Ring	3
37A	07700	O-Ring	3
37B	07653	O-Ring	3
40	13027	V-Sleeve	6

GP5136		#09229	
<u>Item</u>	<u>Part#</u>	<u>Description</u>	<u>Qty.</u>
35A	08183	O-Ring	3
35B	13289	O-Ring	3
36	13291	Grooved Ring	3
40	07144	V-Sleeve	6

GP5142		#09767	
<u>Item</u>	<u>Part#</u>	<u>Description</u>	<u>Qty.</u>
35A	08183	O-Ring	3
35B	13286	O-Ring	3
36	04323	Grooved Ring	3
40	07745	V-Sleeve	6

GP5145		#09228	
<u>Item</u>	<u>Part#</u>	<u>Description</u>	<u>Qty.</u>
35A	13286	O-Ring	3
35B	08183	O-Ring	3
36	13290	Grooved Ring	3
40	13294	V-Sleeve	6

Oil Seal Kit

GP5100 Series, #09230			
<u>Item</u>	<u>Part #</u>	<u>Description</u>	<u>Qty.</u>
31	13284	Oil Seal	3

Valve Assembly Kits

Inlet Valve Kit, GP5100 Series, #09231			
<u>Item</u>	<u>Part #</u>	<u>Description</u>	<u>Qty.</u>
46A	12055	O-Ring	1
46B	08059	O-Ring	1
46C	13304	Valve Seat	1
46D	13306	Valve Plate	1
46E	13307	Valve Spring	1

Discharge Valve Kit, GP5100 Series, # 09232			
<u>Item</u>	<u>Part #</u>	<u>Description</u>	<u>Qty.</u>
47A	13289	O-Ring	1
47B	07700	O-Ring	1
47C	13314	Valve Seat	1
47D	13306	Valve Plate	1
47E	13307	Valve Spring	1

Complete Valve Repair Kit, #09812			
<u>Item</u>	<u>Part #</u>	<u>Description</u>	<u>Qty.</u>
46A	12055	O-Ring	3
46B	08059	O-Ring	3
46C	13304	Inlet Valve Seat	3
46D	13306	Valve Plate	3
46E	13307	Valve Spring	3
46F	13308	Spring Tension Cap	3
46G	13309	Spacer Pipe	3
47A	13289	O-Ring	3
47B	07700	O-Ring	3
47C	13314	Discharge Valve Seat	3
47D	13306	Valve Plate	3
47E	13307	Valve Spring	3
47F	13308	Spring Tension Cap	3
48B	07740	O-Ring	3

GP5132, GP5132-SSP, GP5136 GP5142 & GP5145 Series Torque Specifications and Lubrication Information

<u>Position</u>	<u>Item#</u>	<u>Description</u>	<u>Lubrication/Loctite</u>	<u>Torque Amount</u>
1	13266	Crankcase	Molycote Cu-Paste	
3	05943	Oil Sight Glass Assembly	Loctite 572	22 ft.-lbs. (30 Nm)
10	07008	Inner Hexagon Screw		33 ft.-lbs. (45 Nm)
12	07703	Drain Plug, 3/4" BSP		74 ft.-lbs. (100 Nm)
17	13358	Hexagon Screw		33 ft.-lbs. (45 Nm)
24	13276	Connecting Rod Assy.		22 ft.-lbs. (30 Nm)
29C	13031	Tension Screw, Plunger	Loctite 243	22 ft.-lbs. (30 Nm)
31	13284	Radial Shaft Seal	Loctite 403	
48A	07008	Inner Hexagon Screw, Plug	Pro Pack 550	35 ft.-lbs. (47 Nm)
49	13339	Inner Hexagon Screw, Valve Casing		89 ft.-lbs. (120 Nm)

GP5132, GP5132-SSP, GP5136, GP5142 and GP5145 REPAIR INSTRUCTIONS

To Check Valves

Remove inner hexagon screw (48A) and remove plugs (48) with a screwdriver. Check O-rings on plugs (48). Pull out tension spring (48C). Remove the spring tension disc (47F) from discharge valve lying underneath by screwing in the M10-screw. Take out spring (47E) and plate (47D). Pull out valve seat (47C) by means of an valve puller. Check sealing areas of plate and valve seat for damage and replace worn parts. Check O-rings (47A) and (47B). Screw spacer pipe (46G) out of spring tension cap (46F) in the suction valve lying underneath. Remove suction valve by screwing in an M10-screw. Check O-ring (46A) and (46B). If valve seat (46C) remains in the valve casing (43) then carry forth as described for discharge valve. When reassembling, use new O-rings if possible and oil them before installing.

Tighten inner hexagon screws (48A) to 35 ft.-lbs. (47 Nm).

To Check Seals and Plunger Pipe

Loosen the inner hexagon screws (49) and pull off valve casing (43) to the front. Pull seal sleeves (35) out of guides in crankcase and over the plunger pipe (29B). Pull support ring (41), sleeves (40) and pressure ring (39) out of seal sleeve.

Check plunger surfaces, sleeves (40) and grooved rings (36). Replace worn parts.

If the plunger pipe is worn out, loosen tension screw (29C) and pull off plunger pipe to the front. Clean contact surfaces of plunger (25) thoroughly. Then place new plunger pipe carefully through the oiled seals into the seal case. Check o-rings on seal sleeves and seal case (GP5132/GP5132-SSP only) and replace worn o-rings. Then push seal sleeve together with plunger pipe into the crankcase guide. Turn gear carefully until plunger (25) comes up against the plunger pipe. Put a new copper gasket (29D) onto the tension screw (29C). Cover the thread of tension screw and the gasket with glue and tighten to 29 ft.-lbs. (30 Nm).

Important! Care must be taken that no glue gets between the plunger pipe (29B) and the centering sleeve (29A). The plunger pipe should not be strained by eccentric tightening of the tension screw or through damage to front of surface of plunger, otherwise it will probably break. Tighten the inner screws (49) for the valve casing evenly to 89 ft.-lbs. (120 Nm).

To Dismantle Gear

Drain oil after dismantling valve case and plunger pipes and screw off crankcase cover (4) and bearing cover (14).

Loosen con rod screws (24), push stem of con rod as far as possible into the crosshead guide and carefully push out the radial shaft seals (31).

Important! Connecting rods are marked for identification. Do not twist con rod halves. Con rod is to be reinstalled in the same position on shaft journals.

While slightly turning the crankshaft, hit it out carefully to one side with a rubber hammer.

Important! Do not bend con rod shank. Finally, check surfaces of shaft, con rod, crosshead and plungers (25) as well as radial shaft seals (15, 31) and taper roller bearings (20).

To Reassemble

Using a soft tool, press in the outer bearing ring until it lines up with the outer edge of the bearing hole. Remove bearing cover together with shaft ring and O-ring. Fit shaft with pressed-on bearing parts through the bearing hole on the opposite side. Press in outer bearing ring and tension it inwards with the bearing cover, keeping the shaft in vertical position and turning it slowly so that the taper rollers of the bearings touch the edge of the outer bearing ring. Adjust axial bearing clearance with fitting discs 0.1mm (20A). Shaft should turn easily with very little clearance. Tighten inner hexagon screws on con rod (24) to 22 ft.-lbs. (30 Nm).

Important! There should be enough clearance for the con rod to move sideways a little on the journals.

Important! The 1/2" BSP connection in the crankcase serves the purpose of draining leakage water. The connection should not be closed (see the drawing to the right).

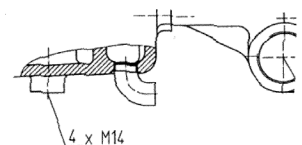

DIMENSIONS

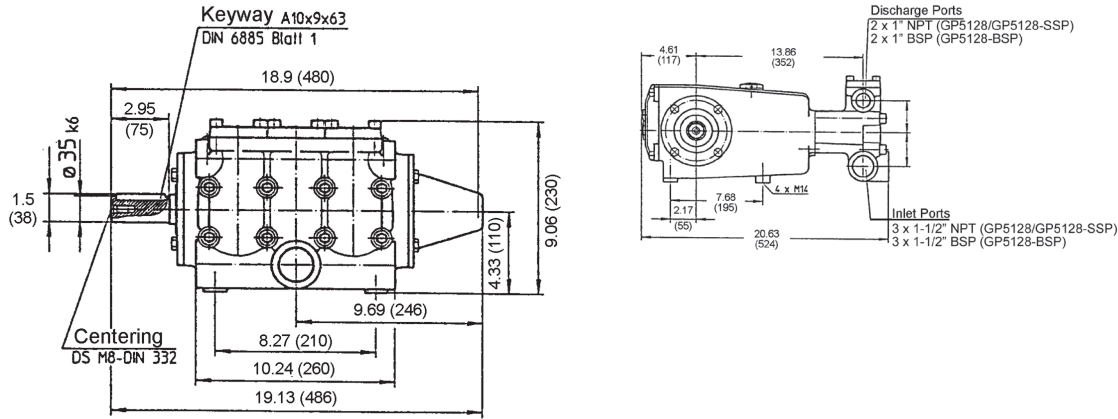

GIANT INDUSTRIES LIMITED WARRANTY

Giant Industries, Inc. pumps and accessories are warranted by the manufacturer to be free from defects in workmanship and material as follows:

1. Five (5) years from the date of shipment for all pumps used in portable pressure washers with NON-SALINE, clean water applications.
2. Two (2) years from the date of shipment for Giant pumps used in car wash applications.
3. One (1) year from the date of shipment for all other Giant industrial and consumer pumps.
4. Six (6) months from the date of shipment for all rebuilt pumps
5. Ninety (90) days from the date of shipment for all Giant accessories.

This warranty is limited to repair or replacement of pumps and accessories of which the manufacturer's evaluation shows were defective at the time of shipment by the manufacturer. The following items are NOT covered or will void the warranty:

1. Defects caused by negligence or fault of the buyer or third party.
2. Normal wear and tear to standard wear parts.
3. Use of repair parts other than those manufactured or authorized by Giant.
4. Improper use of the product as a component part.
5. Changes or modifications made by the customer or third party.
6. The operation of pumps and or accessories exceeding the specifications set forth in the Operations Manuals provided by Giant Industries, Inc.

Liability under this warranty is on all non-wear parts and limited to the replacement or repair of those products returned freight prepaid to Giant Industries which are deemed to be defective due to workmanship or failure of material. A Returned Goods Authorization (R.G.A.) number and completed warranty evaluation form is required prior to the return to Giant Industries of all products under warranty consideration. Call (419)-531-4600 or fax (419)-531-6836 to obtain an R.G.A. number.

Repair or replacement of defective products as provided is the sole and exclusive remedy provided hereunder and the MANUFACTURER SHALL NOT BE LIABLE FOR FURTHER LOSS, DAMAGES, OR EXPENSES, INCLUDING INCIDENTAL AND CONSEQUENTIAL DAMAGES DIRECTLY OR INDIRECTLY ARISING FROM THE SALE OR USE OF THIS PRODUCT.

THE LIMITED WARRANTY SET FORTH HEREIN IS IN LIEU OF ALL OTHER WARRANTIES OR REPRESENTATION, EXPRESS OR IMPLIED, INCLUDING WITHOUT LIMITATION ANY WARRANTIES OR MERCHANTABILITY OR FITNESS FOR A PARTICULAR PURPOSE AND ALL SUCH WARRANTIES ARE HEREBY DISCLAIMED AND EXCLUDED BY THE MANUFACTURER.



WARNING: This product might contain a chemical known to the State of California to cause cancer, and birth defects or other reproductive harm.
For more information go to www.P65Warnings.ca.gov