

Models

Unloader/Regulator

22910A-22913A / 22910AR-22913AR

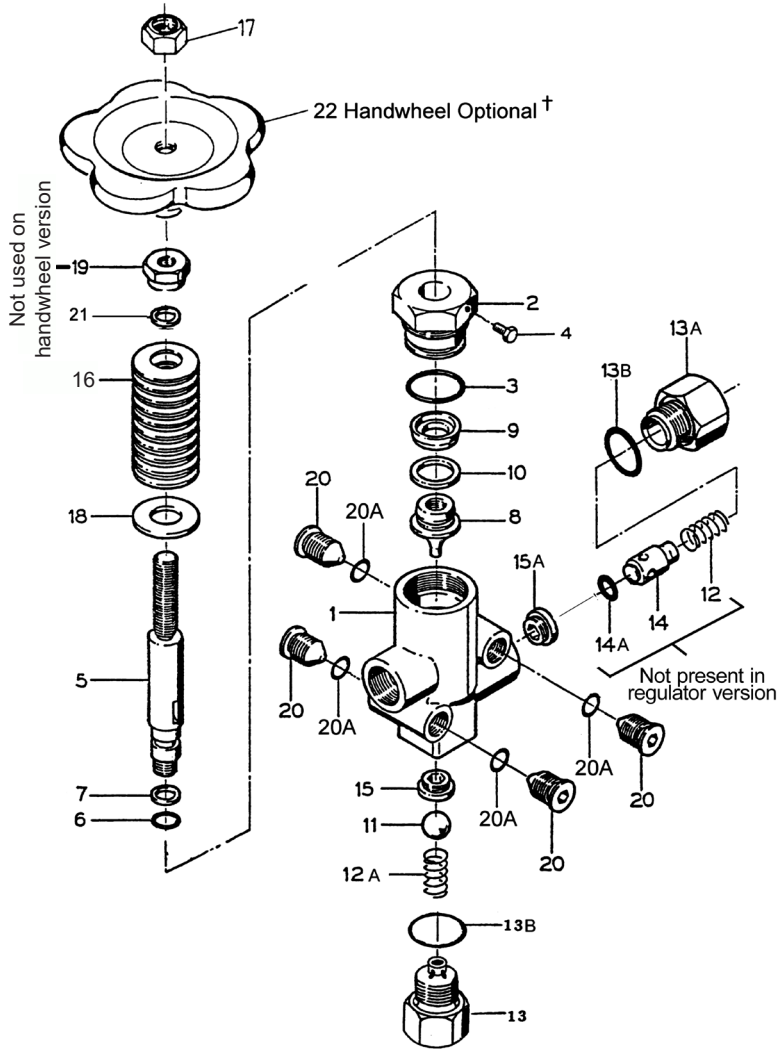

Spare Parts List

Item	Part #	Description	Qty.
1	12112	Valve Body	1
2	12003	Guide Plug	1
3**	12004	O-ring, Valve Cap	1
4	12005	Set Screw with Journal	1
5	12016	Piston Rod	1
6**	11507	O-ring, Valve Stem	1
7**	11508	Back-up ring, Valve Stem	2
8	12015	Piston Body	1
9**	04006	Cup (23mm)	1
10**	04018	Back-up ring, Piston	1
11+	12089	Ball, Inlet	1
12+	12090	Spring, Outlet Valve	1
12A+	12011	Spring, Inlet	1
13	12111	Inlet Adapter	1
13A	12091	Spring Retainer, Outlet Valve	1
13B**	12092	O-ring, Spring Retainer	2
14+	12093	Outlet Valve	1
14A**	12094	O-ring, Outlet Valve	1
15+	12095	Seat, Inlet Valve (S.S.)	1
15A+	12096	Seat, Outlet Valve (Brass)	1
16	22829	Spring, Silver	17
16	22830	Spring, Yellow	14
16	22831Y	Spring, Yellow	3
16	22831	Spring, Red	17
16	22835	Spring, Orange	15
17	12021	Self-Locking Hexagon Nut	1
18	12023	Washer, Spring	1
19	12022	Adjusting Nut	1
		(except handwheel versions)	1
20	06685	Plug, 1/4"	4
20A**	12017	O-ring, Plug	4
21	06686	Spacer Disc, 1.0 mm	max. 5
22	06430	Handwheel (optional)	1
*	12099	Seal Repair Kit	
+	09530	Complete Repair Kit	

† When ordering handwheel, add "H" at the end of the unloader/regulator number.

The bottom three springs are the same thickness as p/n 22831, but all the springs are painted yellow.

OPERATING CONDITIONS

Maximum Flow:	13.2 GPM (50 L/min)
Minimum Flow:	1.3 GPM (5.0 L/min)
Max. Temp:	160 °F (70 °C)
Inlet Port:	1/2" FNPT
Outlet Port:	1/2" FNPT
Bypass:	1/2" BSP

Pressure Range

Model	PSI	Bar	Spring Color
22910A	360-800	25-55	Silver
22911A	360-1450	25-100	Yellow
22912A	360-2000	25-140	Red
22913A	725-3000	50-200	Orange

INSTALLATION & OPERATING INSTRUCTIONS

- 1) The unloader is to be positioned on the discharge side of the pumping unit.
- 2) The bottom port (in) receives the pump discharge.
- 3) The side port (out) is the pressure outlet. Make sure all side ports are tightened securely.
- 4) The backside port (bypass) redirects the pumped media when the pressure outlet is closed.
CAUTION: The bypass line must always be open. No shut-off device is permitted on this side of the unloader.
- 5) The proper sized bypass line can be directed to a holding tank, to atmosphere, or back to the pump inlet.
NOTE: Bypass lines returning to the pump inlet should be equipped with a thermal relief to prevent excessive heat buildup in the bypass line that can be damaged the pumping system during periods of prolonged bypass.
CAUTION: Improper placement of the accumulator can affect the unloader capacity of your unloader and can lead to severe system damage and possible bodily injury.
- 6) If an accumulator is used as a pulsation dampener in your pumping system, the accumulator must be positioned on the downstream side of the unloader.
CAUTION: A properly sized pressure gauge must be used when attempting to adjust your unloader to its pressure setting. Position gauge between the pump and unloader.
- 7) Select the proper spring assembly for your Series 22900 unloader. All spring ratings are based on the maximum operating pressure of the respective unloaders in the series. See reverse side for ratings.
NOTE: Cracking pressures at which the unloader is activated can rise 300-400 PSI over rated operating pressures depending on your system.
- 8) Always adjust unloader springs to system pressure with the system open. Before adjusting, be sure that the spray nozzle orifice is properly sized for the volume and pressure you desire and then fine tune the unloader.

Adjusting Pressure:

- 1) Valve should be tension-free, i.e. loosen nut (17) and adjusting nut (19) so that the piston rod can be moved manually.
- 2) Spring set and adjusting nut (19) -as well as nut (17) on spiral spring design- are to be tensioned while pump is running and with open gun (in case of more guns, all have to be open) until required operating pressure is reached and no more water runs out on bypass side. When the nozzle hole coordinates exactly with flow-rate and pump pressure, no more water should run over bypass when required operating pressure is reached.
- 3) Giant Industries, Inc. strongly recommends the use of a relief valve positioned between the pump and the unloader as a safety backup to unloader malfunction.
IMPORTANT! If the nozzle hole is too small to allow all the fluid to run through the hole after the required operating pressure has been reached, on no account is the valve to be adjusted higher than the maximum operating pressure of the pump. In this case, the bypass is to be left partially open. Nevertheless, it is advisable to have suitable nozzles installed.
IMPORTANT! The spacer discs (21) which are under the adjusting nut (19) are there to keep the adjusted pressure within limits. These discs are not to be removed.

REPAIR INSTRUCTIONS

Renewal of Piston Seals:

Screw guide plug (2) out of valve body and remove set screw (4). Remove piston body (8) by turning counterclockwise with aluminum pliers or tongs (do not use a hard tool). Cut out worn cup. Carefully slide O-ring (6) and support rings (7) onto piston rod. Note order of installation. Clip sleeve support ring (10) and sleeve (9) onto piston body. Check valve body surfaces and guide plugs (dirt or damage wear seals out quickly). Fasten piston body onto piston rod with Loctite 270. Grease all parts lightly with Silicone before reinstalling.

To Check Valves:

Remove spring retainer (13A) and check whether kickback valve taper (14) and seat (15A) are worn out. Check O-ring (14A) for damage. Remove inlet adapter (13) and examine ball (11) and seat (15) for damage. Valve seats can be removed with an inserted allenhead wrench (8 mm). Glue in new valve seats with Loctite 270. Allow to dry for 60 minutes before putting into operation.



WARNING: This product might contain a chemical known to the State of California to cause cancer, and birth defects or other reproductive harm.

For more information go to www.P65Warnings.ca.gov

GIANT

Performance Under Pressure

Giant Industries, Inc.
 900 N. Westwood Ave.
 Toledo, Ohio 43607
 419-531-4600
 Fax: 419-531-6836
www.giantpumps.com

DEFECT	CAUSE	REMEDY
Valve switches repeatedly when gun is closed.	Leaky gun.	Repair gun.
	Leaky pressure pipe.	Seal pressure pipe.
	Leaky cup.	Change cup (9).
	Worn out kick-back valve seat or O-ring.	Change kick-back valve seat (15A) and O-Ring (14A). Examine valve seat.
Leaky piston rod.	Defective O-Ring/ support Ring.	Change piston rod seals (6,7) and examine surface of guide plugs.
Leaky bypass at nominal pressure.	Nozzle too small, too much water.	Install larger nozzle.
	Worn out bypass valve ball.	Examine and change as necessary, ball (11), and bypass valve seat (15).
Pressure gauge shows high pressure fluctuations when shutting off gun.	Valve set too high above operating pressure.	Turn back adjusting nut (19) and hexagon nut (17).
	Dirty valve.	Clean valve (removing lime deposits etc.) Grease parts before reinstalling.