

Models GP7145GB & GP7255AGB Pump with Gearbox

Triplex Ceramic
Plunger Pump
Operation Manual

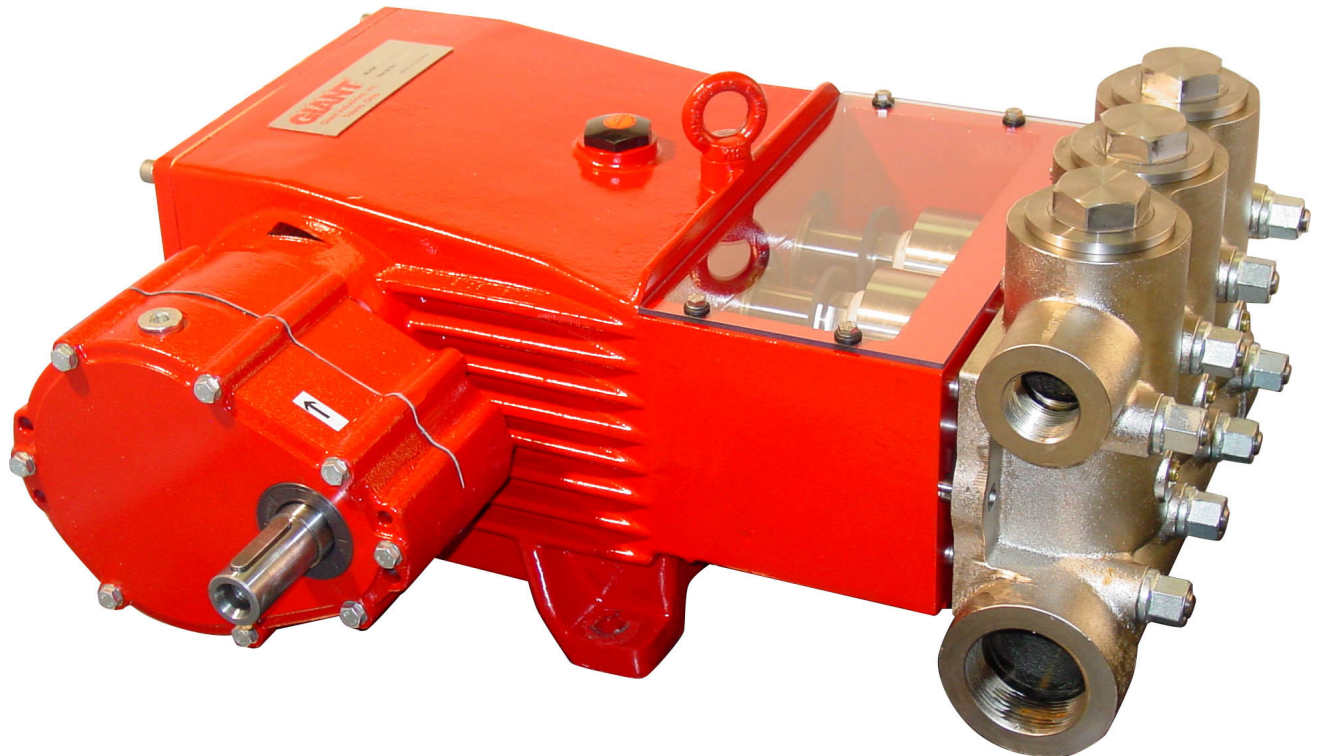

The logo for GIANT, featuring the word "GIANT" in a bold, black, sans-serif font. The letters are stylized with a 3D effect, as if they are stacked or have depth.

Contents:

Installation and Safety Instructions	page 2
Pump Specifications (GP7145GB):	page 3
Exploded View:	page 4
Parts List:	page 5
Pump Specifications (GP7255AGB):	page 6
Kits/Torque Specifications:	page 7
Maintenance Information:	page 7
Repair Instructions:	pages 8-9
Troubleshooting Guide:	page 10
Dimensions:	page 11
Warranty Information	back page

Updated 3/09

INSTALLATION INSTRUCTIONS

Operation and Maintenance

Check oil level prior to starting and ensure trouble-free water supply.

Oil: Use only 1.7 gallons (6.3 liters) of ISO VG-220 synthetic gear oil. Initial change after 50 hours and then after every 200 operating hours. If used less than this, change once per year.

IMPORTANT! When operating in humid areas (or areas with large temperature fluctuations, the oil must be changed immediately (if condensate or frothy oil occurs in the crankcase).

IMPORTANT! We recommend that both inlet ports be used in order to ensure cavitation-free operation and optimal suction conditions. If only one connection is used, a safety margin of 3 feet (1 meter) has to be added to the required NPSH.

IMPORTANT! If the pump is mounted on a vehicle with the possibility of unlevelness and/or the pump speed is between 300 & 500 RPM, the volume of oil should be 1.93 gallons (7.3 liters). To check, put the oil dipstick in the bore situated next to the eye bolt.

IMPORTANT! The GP7145GB and GP7255GB pumps have a black arrow on the reduction gear, which shows the preferred direction of rotation. The pump can be delivered either with the gear on the left side or right side (when facing the front of the pump), which eases planning assembled units with regard to the desired direction or rotation. **In either case, the larger gear wheel must rotate towards the front-end of the pump.**

The preferred/optimal direction of rotation ensures that the oil is correctly splashed on the crosshead guides via the motion of the connecting rods, which is a particular advantage where continuous operation is involved.

The pump can also be run against the recommended direction of the rotation if operated periodically or at reduced pressure. If this is the case, the pump has to be run in this direction to smoothen the bearing areas. This is done by a one-time operation at zero pressure for at least 30 minutes; thereafter, the pressure must be slowly increased over the next hour to the desired maximum operating pressure. This should run-in the pump, but you should also check the oil temperature, which should not exceed 160 ° F (71 °C).

The torque tension on the valve casing nuts (49A) is to be checked after approximately 200 hours. Please see page 7 for torque values.

IMPORTANT! The service life of the seals is maximized if a minimal amount of leakage is present. A few drops of water can drip from each plunger every minute. Leakage has to be examined every day. If the leakage becomes excessive (constant dripping), the plunger seals must be changed.

Safety Rules

The operating instructions must be read and adhered to before performing any work on the pump or complete assembled unit. No responsibility will be carried by us for damage to materials or persons caused by improper handling of our pumps.

Access to the pump is not allowed by unauthorized personnel. As safety valve is to be installed in accordance with the guidelines for liquid spraying units, so that the admissible operating pressure cannot be exceeded by more than 10%. Pumps operating without a safety valve as well as any excess in temperature or speed limits automatically voids the warranty. When the pump is in operating, the exposed shaft side, the driven shaft side and its coupling must be covered by a protective guard. The plunger area must also be covered by the protective plate (30). Do not step onto the protective plate (30) or put weight on it.

Before carrying out any maintenance work to the pump or pump unit, the pressure in the discharge line and pump must be at zero. Close off the suction line. Disconnect fuses to ensure that the driving motor cannot accidentally get switched on. Before starting the pump, make sure that the pump, the cooling system and all parts on the pressure side of the unit are vented and refilled with pressure at zero.

In order to prevent air or air/water-mixture being absorbed and cavitation occurring, the pump NPSHR (Net Positive Suction Head Required) and water temperature must be adhered to.

Cavitation and/or compression of gases lead to uncontrollable pressure kicks, which can ruin the pump and unit parts and also be dangerous to the operator or anyone standing nearby.

Giant plunger pumps are only suitable for pumping fresh clean water.

**NOTE: Contact Giant Industries
for Service School Information.
Phone: (419)-531-4600.**

Specifications

Model GP7145GB

	U.S.	(Metric)
Volume (Continuous).....	47.5 GPM	(180 LPM)
Volume (Intermittent).....	60 GPM*	(227 LPM)*
Discharge Pressure	3000 PSI	(207 bar)*
Speed (Continuous).....		750 RPM
Speed (Intermittent).....		947 RPM
Inlet Pressure (maximum)	145 PSI	(10 bar)
Plunger Diameter.....	1.77"	45mm
Plunger Stroke.....	2.0"	52mm
Crankshaft Diameter.....	1.9"	48mm
Key Width	0.6"	14mm
Crankshaft Mounting		Either side
Shaft Rotation.....		See Instructions on page 2
Temperature of Pumped Fluids	Up to 140 °F	(60 °C)
Inlet Ports		(2) 2-1/2" NPT
Discharge Ports		(2) 1-1/4" NPT
Weight	418 lbs.	(190 kg)
Crankcase Oil Capacity	1.7 Gal.	(6.3 liter)
Fluid End Material.....		Spheroidal Cast Iron

Consult the factory for special requirements that must be met if the pump is to operate beyond one or more of the limits specified above.

PULLEY INFORMATION

Pulley selection and pump speed are based on a 1725 RPM motor and "B" section belts. When selecting desired GPM, allow for a ±5% tolerance on pumps output due to variations in pulleys, belts and motors among manufacturers.

1. Select GPM required, then select appropriate motor and pump pulley from the same line.
2. The desired pressure is achieved by selecting the correct nozzle size that corresponds with the pump GPM.

HORSEPOWER INFORMATION

Horsepower ratings shown are the power requirements for the pump. Gas engine power outputs must be approximately twice the pump power requirements shown above.

We recommend that a 1.15 service factor be specified when selecting an electric motor as the power source. To compute specific pump horsepower requirements, use the following formula:

$$(GPM \times PSI) / 1450 = HP$$

GP7145GB PULLEY SELECTION & HORSEPOWER REQUIREMENTS							
Input RPM	RPM	GPM	800 PSI	1000 PSI	1500 PSI	2000 PSI	3000 PSI*
720	300	19.0	10.5	13.1	19.7	26.2	39.3
960	400	25.3	14.0	17.4	26.2	34.9	52.3
1200	500	31.7	17.5	21.9	32.8	43.7	65.6
1440	600	38.0	21.0	26.2	39.3	52.4	78.6
1800	750	47.5	26.2	32.8	49.1	65.5	98.3
1894	789	50.0	27.6	34.5	51.7	69.0	103.4
2273	947	60.0	33.1	41.4	41.4	82.8	124.1

*Intermittent duty only

Exploded View - GP7145GB / GP7255AGB

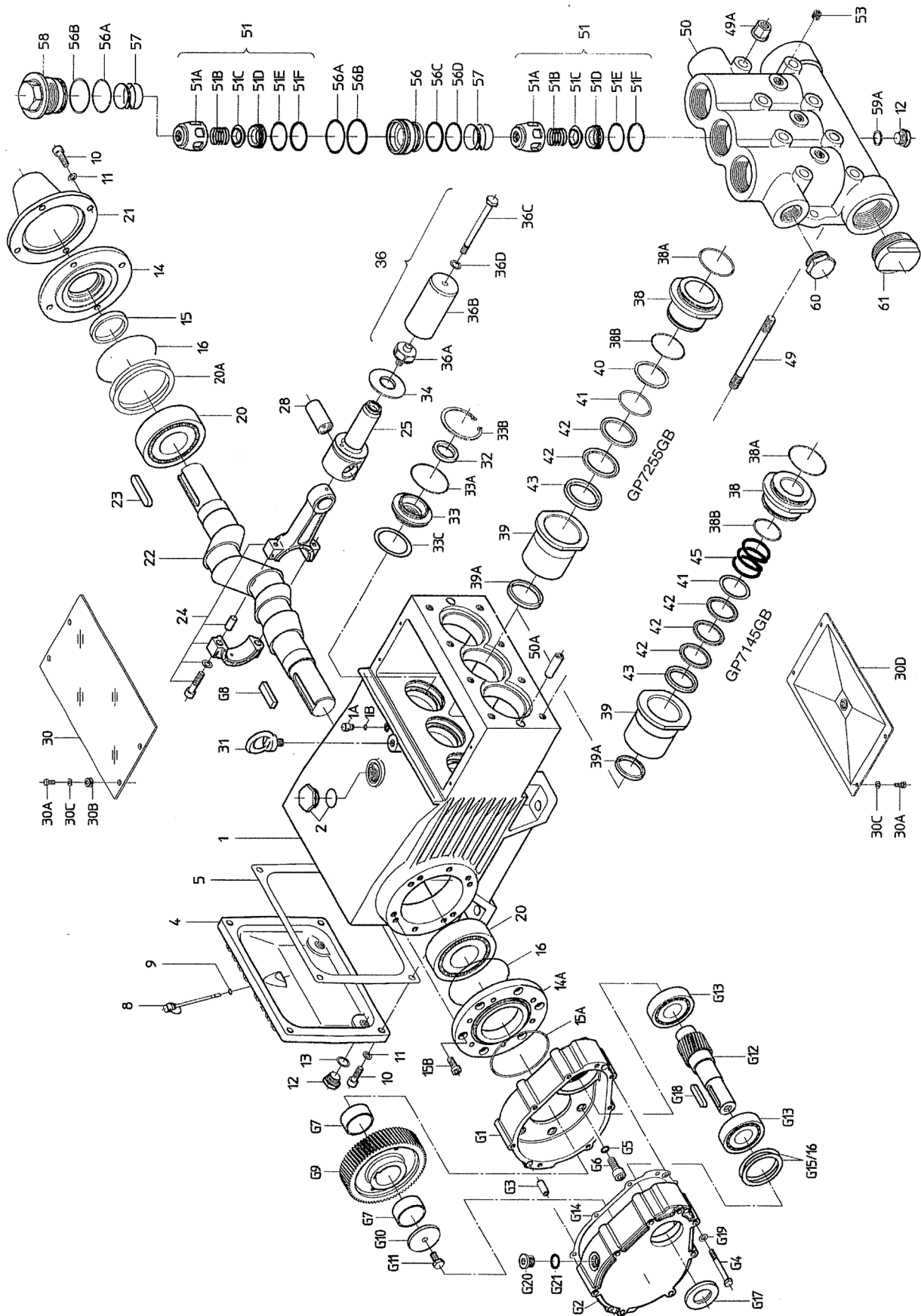

PARTS LIST - GP7145GB / GP7255AGB

<u>ITEM</u>	<u>PART</u>	<u>DESCRIPTION</u>	<u>QTY.</u>	<u>ITEM</u>	<u>PART</u>	<u>DESCRIPTION</u>	<u>QTY.</u>
1	05324	Crankcase	1	41	13296	Support Ring, GP7145	3
1A	05313	Head for Oil Dipstick	1	41	13158	Support Ring, GP7255A	3
1B	01009	O-Ring	1	42	13294	V-Sleeve, GP7145	9
2	13000	Oil Filler Plug Assy.	1	42	07711	V-Sleeve, GP7255A	6
4	07601	Crankcase Cover	1	43	13293	Pressure Ring, GP7145	3
5	07602	Gasket, Crankcase Cover	1	43	07712	Pressure Ring, GP7255A	3
8	07603	Oil Dip Stick	1	45	13297	Tension Spring, GP7145 only	3
9	01009	O-Ring, Dip Stick	1	49	13159	Stud Bolt	8
10	22706	Hexagon Screw	8	49A	13160	Hexagon Nut	8
11	06725	Spring Washer	8	50	07791	Valve Casing	1
12	07109	Drain Plug	3	50A	13162	Cylinder Stud	2
13	07182	Gasket, Drain Plug	2	51	05274	Valve Assembly (51A-51F)	6
14	07607	Bearing Cover	1	51A	13165	Spacer Pipe	6
14A	05325	Flange for Gearbox	1	51B	07732-0100	Valve Spring	6
15	07608	Radial Shaft Seal	1	51C	05314	Valve Plate	6
15A	05326	O-Ring	1	51D	05136A	Valve Seat	6
15B	05327	Hexagon Socket Screw	6	51E	07653	O-Ring	6
16	07184	O-Ring	2	51F	13166	Support Ring	6
20	07610	Taper Roller Bearing	2	53	22610	Plug	3
20A	07611	Fitting Disc (Shim)	1-5	56	13167	Valve Adaptor	3
21	07612	Shaft Protector	1	56A	07658	O-Ring for 56, 58	6
22	13405	Crankshaft	1	56B	07635	Support Ring for 56A, 58A	6
23	07614	Key	1	56C	13166	Support Ring	3
24	13182	Connecting Rod Assy.	3	56D	07653	O-Ring	3
25	13183	Crosshead Assy.	3	57	13173	Tension Spring	6
28	13184	Crosshead Pin	3	58	13170	Plug, M64 x 2	3
30	07619	Cover Plate	1	59A	07661	Copper Ring for 12	1
30A	07225-0100	Hexagon Screw	8	60	12251	Plug, 1-1/4" NPT	1
30B	13136	Grommet	4	61	05170	Plug, 2-1/2" NPT	1
30C	08280	Disc	8		05344	Gearbox Assy, 2.4:1 (G1-G21)	1
30D	13154	Cover Plate	1	G1	05328	Casing, Bottom	1
31	07623	Eye Bolt	1	G2	05329	Casing, Top	1
32	07624	Radial Shaft Seal	3	G3	05330	Cylindrical Pin	2
33	07626	Seal Retainer	3	G4	05331	Hexagon Screw	8
33A	07627	O-Ring	3	G5	05332	Washer	6
33B	07628	Circlip	3	G6	07008	Hexagon Socket Screw	6
33C	07249	Fitting Disc	3	G7	05333	Spacer Ring	2
34	13137	Oil Scraper	3	G8	05334	Fitting Key	1
36	06165	Plunger Pipe Assy. (36A-D), GP7145	3	G9	05335	Cogwheel	1
36	07706	Plunger Pipe Assy. (36A-D), GP7255A	3	G10	05336	Tension Disc	1
36A	07667	Plunger Connection	3	G11	13358	Hexagon Screw	1
36B	05157	Plunger Pipe, GP7145	3	G12	05337	Pinion	1
36B	07666	Plunger Pipe, GP7255A	3	G13	05378	Roller Bearing, Self-Aligning	2
36C	06166	Tension Screw, GP7145	3	G14	05511	Gear Seal	1
36C	07664	Tension Screw, GP7255A	3	G15	05338	Fitting Disc, 0.1mm	2
36D	07665	Copper Ring	3	G16	05339	Fitting Disc, 0.2mm	2
38	06167	Seal Case, GP7145	3	G17	05340	Shaft Seal Ring	1
38	13155	Seal Case, GP7255A	3	G18	13243	Fitting Key	1
38A	13156	O-Ring for 38	3	G19	05341	Washer	2
38B	06258	O-Ring for 38, GP7145	3	G20	05342	Screw Plug	2
38B	07721	O-Ring for 38, GP7255A	3	G21	05343	Copper Ring	2
39	06171	Seal Sleeve, GP7145	3		07662	Valve Tool (Not Shown)	1
39	13157	Seal Sleeve, GP7255A	3		05210	Plunger Conversion Assy. (36-45), GP7145	1
39A	13290	Grooved Ring, GP7145	3		05211	Plunger Conversion Assy., (36-45), GP7255A	1
39A	07723	Grooved Ring, GP7255	3				
40	07797	Support Disc, GP7255 only	3				

Specifications

Model GP7255AGB

	U.S.	(Metric)
Volume (Continuous).....	65.8 GPM	(250 LPM)
Volume (Intermittent).....	80 GPM*	(303 LPM)*
Discharge Pressure (Continuous)	1500 PSI	(100 bar)
Discharge Pressure (Intermittent).....	2000 PSI	(140 bar)*
Speed (Continuous).....	700 RPM	
Speed (Intermittent).....	851 RPM	
Inlet Pressure (maximum)	145 PSI	(10 bar)
Plunger Diameter.....	2.17"	55mm
Plunger Stroke.....	2.0"	52mm
Crankshaft Diameter.....	1.9"	48mm
Key Width	0.6"	14mm
Crankshaft Mounting		Either side
Shaft Rotation.....		See Instructions on page 2
Temperature of Pumped Fluids	Up to 140 °F	(60 °C)
Inlet Ports		(2) 2-1/2" NPT
Discharge Ports		(2) 1-1/4" NPT
Weight	418 lbs.	(190 kg)
Crankcase Oil Capacity.....	1.7 Gal.	(6.3 liter)
Fluid End Material.....		Spheroidal Cast Iron

Consult the factory for special requirements that must be met if the pump is to operate beyond one or more of the limits specified above.

PULLEY INFORMATION

Pulley selection and pump speed are based on a 1725 RPM motor and "B" section belts. When selecting desired GPM, allow for a ±5% tolerance on pumps output due to variations in pulleys, belts and motors among manufacturers.

1. Select GPM required, then select appropriate motor and pump pulley from the same line.
2. The desired pressure is achieved by selecting the correct nozzle size that corresponds with the pump GPM.

HORSEPOWER INFORMATION

Horsepower ratings shown are the power requirements for the pump. Gas engine power outputs must be approximately twice the pump power requirements shown above.

We recommend that a 1.15 service factor be specified when selecting an electric motor as the power source. To compute specific pump horsepower requirements, use the following formula:

$$(GPM \times PSI) / 1450 = HP$$

GP7255AGB PULLEY SELECTION & HORSEPOWER REQUIREMENTS							
Input RPM	RPM	GPM	800 PSI	1000 PSI	1300 PSI	1500 PSI	2000 PSI*
1150	479	45.0	24.8	31.0	40.3	46.6	62.1
1274	531	49.9	27.5	34.4	44.7	51.6	68.8
1404	585	55.0	30.3	37.9	49.3	56.9	75.9
1531	638	60.0	33.1	41.4	53.8	62.1	82.8
1680	700	65.8	36.3	45.4	59.0	68.1	90.8
2042	851	80.0*	44.1	55.2	71.7	82.8	110.3

*Intermittent duty only

Repair Kits - GP7145GB and GP7255AGB

Plunger Packing Kit - GP7145GB

09603

Item	Part #	Description	Qty.
38A	13156	O-Ring	3
38B	06258	O-Ring	3
39A	13290	Grooved Ring	3
41	13296	Support Ring	3
42	13294	V-Sleeve	9

Plunger Packing Kit - GP7255AGB

09220

Item	Part #	Description	Qty.
38A	13156	O-Ring	3
38B	07721	O-Ring	3
39A	07723	Grooved Ring	3
41	13158	Support Ring	3
42	07711	V-Sleeve	6

Valve Repair Kit

09604A

Item	Part #	Description	Qty.
51B	07732-0100	Valve Spring	1
51C	05314	Valve Plate	1
51D	05136A	Valve Seat	1
51E/56D	07653	O-Ring	2
51F/56C	13166	Support Ring	2
56A	07658	O-Ring	2
56B	07635	Support Ring	2

Oil Seal Kit

09221

Item	Part #	Description	Qty.
32	07624	Radial Shaft Seal	3
33A	07627	O-Ring	3

GP7145GB and GP7255AGB Torque Specifications

Position	Item#	Description	Torque Amount
15B	05327	Hexagon Socket Screw	36.1 ft-lbs (49 Nm)
24	13182	Connecting Rod Assembly	30 ft.-lbs. (40 Nm)
36C	06166/07664	Tension Screw	30 ft.-lbs. (40 Nm)
49A	13160	Hexagon Nut	103 ft.-lbs. (140 Nm)
58	13170	Plug	107 ft-lbs (145 Nm)
G4	05331	Hexagon Screw	18.4 ft-lbs (25 Nm)
G6	07008	Hexagon Socket Screw	33.2 ft-lbs (45 Nm)

Preventative Maintenance Check-List & Recommended Spare Part List						
Check	Daily	Weekly	50 hrs	Every 200 hrs	Every 1500 hrs	Every 3000 hrs
Oil Level / Quality	X					
Oil Leaks	X					
Water Leaks	X					
Belts, Pulley		X				
Plumbing		X				
Recommended Spare Parts						
Oil Change			X	X		
Plunger Packing Kits (1 kit/Pump)					X	
Oil Seal Kit (1 kit/Pump)					X	
Valve Kit (1 kit/pump)						X

GP7145GB and GP7255AGB Repair Instructions

TO CHECK VALVES

Loosen plugs (58), take out tension spring (57) and then remove the complete valve assembly (51) with either a valve tool or an M16 hexagon screw. To remove the valve adapter (56) and tension spring (57), use a pullout tool size 5. If valve adapter is removed with valve assembly, simply twist the valve assembly out of the valve adapter. To disassemble valve assembly: screw valve seat (51D) out of spacer pipe (51A). Check sealing surfaces and replace worn parts. Check o-rings and support rings. Tighten plugs (58) to 107 ft.-lbs. (145 Nm).

TO CHECK SEALS AND PLUNGER PIPE

Loosen nuts (49A) and remove pump head (50). Separate the plunger connection (36A) from the crosshead (25) by means of an open-end 36mm wrench. Pull seal sleeves (39) out of their fittings in the crankcase (1). Take the seal case (38) out of the seal sleeve (39). Examine the plunger parts (36A-36D), seals (42 & 39A) and O-rings (38A & 38B). When replacing the plunger pipe (36B), tighten tension screws (36C) to 30 ft. lbs. (40 Nm). Replace worn parts; grease seals with Silicone before installing.

CAUTION: Don't loosen the 3 plunger connections (36A) before the valve casing has been removed otherwise the tension screw (36C) could hit against the valve adapter (56) when the pump is being turned. Seal life can be increased if the pre-tensioning allows for a little leakage. This assists lubrication and keeps the seals cool. It is therefore not necessary to replace seals before the leakage becomes too heavy and causes output and operating pressure to drop.

MOUNTING VALVE CASING

Check O-rings (38A & 38B) on the seal case (38). Clean surfaces of seal sleeves in gear box and sealing surfaces of valve casing (50). Push the valve casing carefully on the O-rings of the seal case and centering studs (50A). Tighten nuts (49A) to 103 ft. lbs. (140 Nm).

TO DISASSEMBLE GEAR

Take out plunger (36) and seal sleeves (39) as described above. Drain the oil. After removing the circlip ring (33B), lever out seal retainer (33) with a screw driver. Check seals (32 & 33A) and surfaces of crosshead (25) .

Important! Seal (32) must always be installed so that the seal-lip on the inside diameter faces the oil. Possible axial float of the seal retainer (33) should be compensated with the shims (33C).

Remove the crankcase cover (4). Loosen inner hexagon screws on the connecting rods (24).

Note: Connecting rods are marked for identification. Do not twist connecting rod halves. Each connecting rod is to be reinstalled in the same position (and orientation) on the crankshaft journals.

Push the connecting rod halves as far into the crosshead guide as possible. Take out the bearing cover (14).

GP7145GB and GP7255AGB Repair Instructions

TO DISMANTLE REDUCTION GEAR

Remove screws (G4). Remove the gear cover (G2). It may be necessary to tap the cover off with a rubber mallet. Remove screw (G11) and take off the spacer ring (G7) and tension disc (G10). Push the cogwheel (G9) off the shaft by screwing two screws into both thread bores. Unscrew hexagon screws (10) and remove the shaft cover (21) and bearing cover (14). Finally, take the crankshaft (22) out of the crankcase by tapping it towards the bearing cover side, opposite the gearbox, using a rubber hammer.

Check the surfaces of connecting rods (24), crankshaft (22) and crossheads (25). Check the surfaces of the crosshead guides in the crankcase for any unevenness.

Reassemble in reverse order. Regulate axial bearing clearance to a minimum of 0.1mm and a maximum 0.15mm by means of fitting discs (20A). Insert the crankshaft by passing it through on the bearing cover side. Press in the outer bearing ring (20). The crankshaft should turn easily and with little clearance. Fit the bearing cover (14) and tighten screws (24) to 30 ft.-lbs. (40 Nm).

Important! The connecting rod has to be able to slightly move sidewise at the crankshaft journal.

Heat the ball bearings (G13) before pressing them onto the pinion (G12). Slightly press the cogwheel (G9) onto the crankshaft, so that the pinion (G12) together with the bearing (G13) can still be inserted.

When mounting, place the pinion (G12) onto the cogwheel so that they correctly interlock.
Carefully tap
the cogwheel and the pinion simultaneously onto the crankshaft and into the bearing seat.

Fit tension disc (G10), and spacer ring (G7) and tighten screw (G11) with Loctite.

Fit seal (G14) on to the cylindrical pins (G3).

Push the gear cover (G2) carefully on to the bearing (G13). Make sure the radial shaft seal (G17) does not get damaged during fitting on to the pinion.

Important! Before putting into operation again, turn the reduction gear shaft by hand at least four full turns to make sure that the gear is correctly aligned.

PUMP SYSTEM MALFUNCTION

<u>MALFUNCTION</u>	<u>CAUSE</u>	<u>REMEDY</u>
The Pressure and/or the Delivery Drops	Worn packing seals Broken valve spring Belt slippage Worn or Damaged nozzle Fouled discharge valve Fouled inlet strainer Worn or Damaged hose Worn or Plugged relief valve on pump Cavitation Unloader	Replace packing seals Replace spring Tighten or Replace belt Replace nozzle Clean valve assembly Clean strainer Repair/Replace hose Clean, Reset, and Replace worn parts Check suction lines on inlet of pump for restrictions Check for proper operation
Water in crankcase	High humidity Worn seals	Reduce oil change interval Replace seals
Noisy Operation	Worn bearings Cavitation	Replace bearings, Refill crankcase oil with recommended lubricant Check inlet lines for restrictions and/or proper sizing
Rough/Pulsating Operation with sure Drop	Worn packing Inlet restriction Accumulator pressure Unloader Cavitation	Replace packing Check system for stoppage, air leaks, correctly sized inlet plumbing to pump Recharge/Replace accumulator Check for proper operation Check inlet lines for restrictions and/or proper size
Pump Pressure as Rated, Pressure Drop at gun	Restricted discharge plumbing	Re-size discharge plumbing to flow rate of pump
Excessive Leakage	Worn plungers Worn packing/seals Excessive vacuum Cracked plungers Inlet pressure too high	Replace plungers Adjust or Replace packing seals Reduce suction vacuum Replace plungers Reduce inlet pressure
High Crankcase Temperature	Wrong Grade of oil Improper amount of oil in crankcase	Right oil is recommended Adjust oil level to proper amount

Dimensions - GP7145GB and GP7255AGB - Inches (mm)

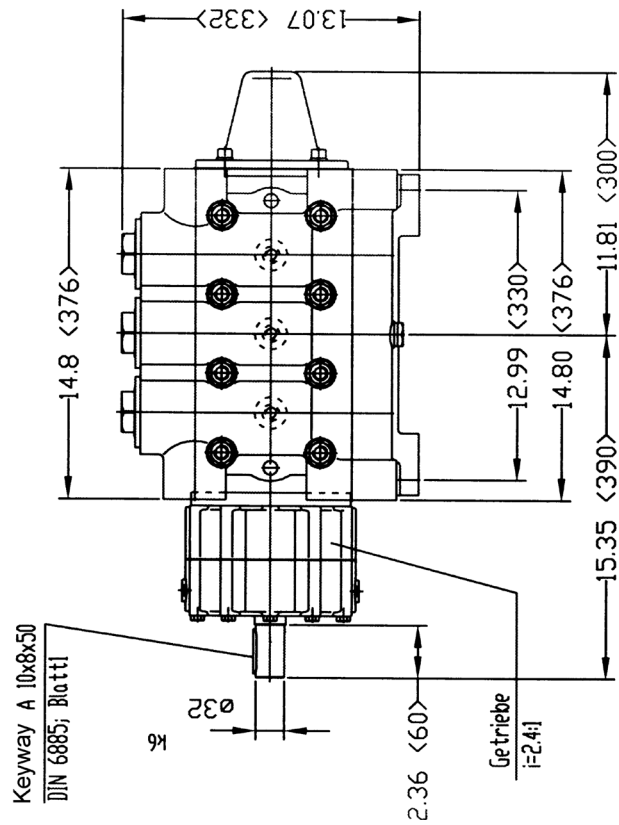
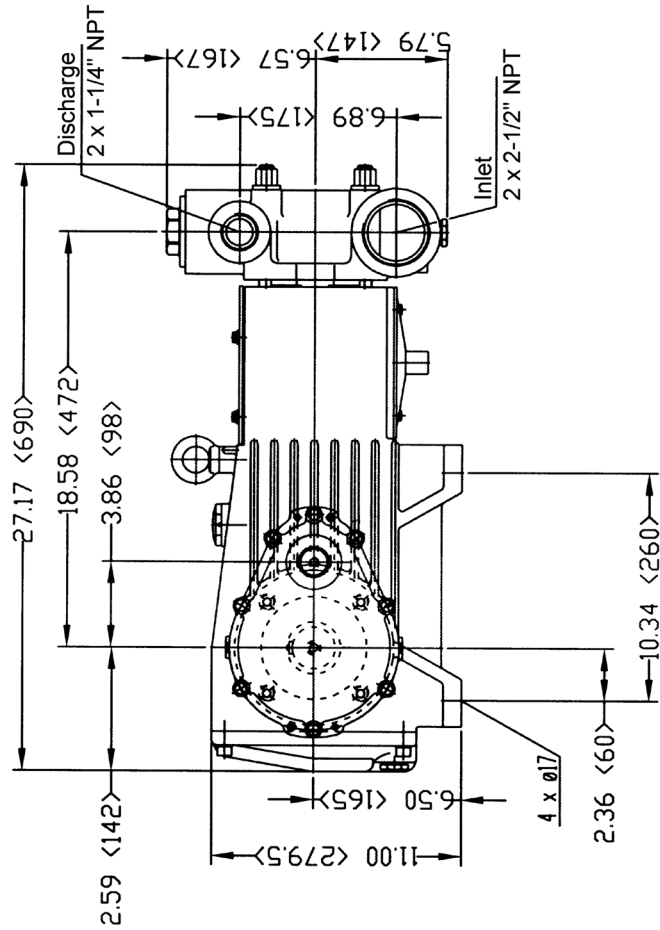

GIANT INDUSTRIES LIMITED WARRANTY

Giant Industries, Inc. pumps and accessories are warranted by the manufacturer to be free from defects in workmanship and material as follows:

1. For portable pressure washers and self-serve car wash applications, the discharge manifolds will never fail, period. If they ever fail, we will replace them free of charge. Our other pump parts, used in portable pressure washers and in car wash applications, are warranted for five years from the date of shipment for all pumps used in NON-SALINE, clean water applications.
2. One (1) year from the date of shipment for all other Giant industrial and consumer pumps.
3. Six (6) months from the date of shipment for all rebuilt pumps.
4. Ninety (90) days from the date of shipment for all Giant accessories.

This warranty is limited to repair or replacement of pumps and accessories of which the manufacturer's evaluation shows were defective at the time of shipment by the manufacturer.

The following items are NOT covered or will void the warranty:

1. Defects caused by negligence or fault of the buyer or third party.
2. Normal wear and tear to standard wear parts.
3. Use of repair parts other than those manufactured or authorized by Giant.
4. Improper use of the product as a component part.
5. Changes or modifications made by the customer or third party.
6. The operation of pumps and or accessories exceeding the specifications set forth in the Operations Manuals provided by Giant Industries, Inc.

Liability under this warranty is on all non-wear parts and limited to the replacement or repair of those products returned freight prepaid to Giant Industries which are deemed to be defective due to workmanship or failure of material. A Returned Goods Authorization (R.G.A.) number and completed warranty evaluation form is required prior to the return to Giant Industries of all products under warranty consideration. Call (419)-531-4600 or fax (419)-531-6836 to obtain an R.G.A. number.

Repair or replacement of defective products as provided is the sole and exclusive remedy provided hereunder and the MANUFACTURER SHALL NOT BE LIABLE FOR FURTHER LOSS, DAMAGES, OR EXPENSES, INCLUDING INCIDENTAL AND CONSEQUENTIAL DAMAGES DIRECTLY OR INDIRECTLY ARISING FROM THE SALE OR USE OF THIS PRODUCT.

THE LIMITED WARRANTY SET FORTH HEREIN IS IN LIEU OF ALL OTHER WARRANTIES OR REPRESENTATION, EXPRESS OR IMPLIED, INCLUDING WITHOUT LIMITATION ANY WARRANTIES OR MERCHANTABILITY OR FITNESS FOR A PARTICULAR PURPOSE AND ALL SUCH WARRANTIES ARE HEREBY DISCLAIMED AND EXCLUDED BY THE MANUFACTURER.



GIANT INDUSTRIES, INC.

900 N. Westwood Ave.

P.O. Box 3187

Toledo, Ohio 43607

(419) 531-4600

FAX (419) 531-6836

© Copyright 2009 Giant Industries, Inc.

www.giantpumps.com